

ETSI EN 300 396-5 V1.3.1 (2011-12)



**Terrestrial Trunked Radio (TETRA);
Technical requirements for Direct Mode Operation (DMO);
Part 5: Gateway air interface**

Reference

REN/TETRA-08195

Keywords

air interface, gateway, protocol, radio, TETRA

ETSI

650 Route des Lucioles
F-06921 Sophia Antipolis Cedex - FRANCE

Tel.: +33 4 92 94 42 00 Fax: +33 4 93 65 47 16

Siret N° 348 623 562 00017 - NAF 742 C
Association à but non lucratif enregistrée à la
Sous-Préfecture de Grasse (06) N° 7803/88

Important notice

Individual copies of the present document can be downloaded from:

<http://www.etsi.org>

The present document may be made available in more than one electronic version or in print. In any case of existing or perceived difference in contents between such versions, the reference version is the Portable Document Format (PDF). In case of dispute, the reference shall be the printing on ETSI printers of the PDF version kept on a specific network drive within ETSI Secretariat.

Users of the present document should be aware that the document may be subject to revision or change of status. Information on the current status of this and other ETSI documents is available at

<http://portal.etsi.org/tb/status/status.asp>

If you find errors in the present document, please send your comment to one of the following services:

http://portal.etsi.org/chaicor/ETSI_support.asp

Copyright Notification

No part may be reproduced except as authorized by written permission.
The copyright and the foregoing restriction extend to reproduction in all media.

© European Telecommunications Standards Institute 2011.
All rights reserved.

DECT™, **PLUGTESTS™**, **UMTS™** and the ETSI logo are Trade Marks of ETSI registered for the benefit of its Members.
3GPP™ and **LTE™** are Trade Marks of ETSI registered for the benefit of its Members and of the 3GPP Organizational Partners.
GSM® and the GSM logo are Trade Marks registered and owned by the GSM Association.

Contents

Intellectual Property Rights	15
Foreword.....	15
1 Scope	16
2 References	16
2.1 Normative references	16
2.2 Informative references.....	17
3 Definitions and abbreviations.....	17
3.1 Definitions.....	17
3.2 Abbreviations	21
4 Overview of protocol.....	22
4.1 General	22
4.2 The DM channel.....	24
4.3 DM call procedures for operation with a gateway.....	25
4.3.1 Constraints on the frame structure	26
4.3.2 Setting up a call through a DM-GATE.....	27
4.3.2.1 Group call from TMO to DM-MS via a DM-GATE.....	27
4.3.2.2 Group call from DM-MS via a DM-GATE.....	29
4.3.2.3 Individual call from TM-MS to DM-MS via a DM-GATE	31
4.3.2.4 Individual call from DM-MS to TM-MS via a DM-GATE	34
4.3.3 Changeover in a call via a DM-GATE.....	36
4.3.4 Pre-emption of a direct mode call through a DM-GATE.....	38
4.3.5 Short Data Service through a gateway.....	39
4.3.6 Group call from DM-MS via DM-REP/GATE.....	40
5 DM-MS layer 3 service description (for operation with a gateway).....	41
5.1 Introduction	41
5.2 Services offered at the DMCC-SAP.....	41
5.3 Description of primitives at the DMCC-SAP.....	41
5.4 Description of parameters at the DMCC-SAP.....	42
5.5 States for DMCC-SAP	43
5.6 Services offered at the DMMM-SAP	43
5.7 Description of primitives at the DMMM-SAP	43
5.7.1 DMMM-REGISTRATION primitive	44
5.7.2 DMMM-REPORT primitive.....	44
5.8 Description of parameters at the DMMM-SAP.....	44
6 DM-MS layer 3 protocol (for operation with a gateway).....	45
6.1 Introduction	45
6.1.1 DMCC protocol states	45
6.1.2 DMMM protocol states.....	45
6.1.2.1 NOT-REGISTERED.....	45
6.1.2.2 WAIT-REGISTRATION.....	46
6.1.2.3 REGISTRATION-ACCEPTED.....	46
6.1.2.4 REGISTRATION-REJECTED.....	46
6.2 Circuit mode calls.....	46
6.2.1 Procedures for outgoing call set-up through a gateway	47
6.2.1.1 Outgoing call set-up	47
6.2.1.2 Temporary group address.....	49
6.2.1.3 Layer 3 addressing in DM-GSETUP PDU.....	49
6.2.1.3.1 Called party address	49
6.2.1.3.2 Area selection	49
6.2.1.3.3 Calls to external subscribers	49
6.2.1.3.4 Calling party address	49
6.2.2 Procedures for incoming call set-up.....	49
6.2.2.1 Incoming call set-up without presence check.....	49

6.2.2.2	Incoming call set-up with presence check.....	50
6.2.2.3	Transmitting Party Number Identification (TPNI) during incoming call set-up	50
6.2.3	Usage of DM-OCCUPIED PDU	50
6.2.3.1	Sending of DM-OCCUPIED PDU by master DM-MS.....	50
6.2.3.2	Late entry by slave DM-MS.....	50
6.2.4	Procedures during occupation.....	51
6.2.4.1	Master DM-MS	51
6.2.4.2	Slave DM-MS	51
6.2.4.3	Transmitting Party Number Identification (TPNI) during occupation	53
6.2.4.3.1	Master DM-MS	53
6.2.4.3.2	Slave DM-MS.....	53
6.2.5	Procedures during reservation.....	53
6.2.5.1	Master DM-MS	53
6.2.5.2	Slave DM-MS	54
6.2.5.3	Pre-emption of short data sent as a transaction within a circuit mode call.....	54
6.2.6	Procedures to set up a new call by pre-emption.....	55
6.3	Short Data Service (SDS) procedures	55
6.3.1	Sending short data.....	56
6.3.1.1	Sending short data on a free channel.....	56
6.3.1.1.1	Sending unacknowledged short data on a free channel	56
6.3.1.1.2	Sending acknowledged short data on a free channel	56
6.3.1.2	Sending short data by pre-emption.....	56
6.3.1.3	Sending short data during circuit mode transmission.....	56
6.3.1.4	Sending short data as a transaction within a circuit mode call	57
6.3.1.4.1	Pre-emption to send short data as a transaction within a circuit mode call	57
6.3.1.4.2	Changeover to send short data as a transaction within a circuit mode call.....	57
6.3.1.4.3	Sending the short data as master of the circuit mode call.....	57
6.3.2	Receiving short data.....	57
6.3.2.1	Receiving unacknowledged short data	57
6.3.2.2	Receiving acknowledged short data	58
6.3.3	Additional addressing	58
6.3.3.1	DM-MS sending short data	58
6.3.3.2	DM-MS receiving short data	58
6.3.4	Extended error protection	58
6.3.5	SDS-TL service in DMO	58
6.3.5.1	Service primitives at the DMTL-SAP	58
6.3.5.2	DMTL-SDS primitives' parameters	59
6.3.5.3	DMTL-SDS PDUs	59
6.3.5.4	DMTL-SDS procedures	59
6.4	Procedures for mobility management.....	59
6.4.1	Solicited registration	59
6.4.2	Unsolicited registration.....	60
6.4.3	Cancellation of registration by gateway.....	60
6.4.4	Other criteria for DMMM state change	60
6.4.5	Action on entering state REGISTRATION-REJECTED.....	61
6.4.6	Layer 3 addressing in DM-GREGISTER REQUEST PDU.....	61
6.5	Usage of DMA-UNITDATA primitive	61
6.5.1	Sending a DMCC PDU	61
6.5.2	Sending a DMMM PDU	61
6.5.3	Protocol control function for delivery of received message	61
6.6	General procedures.....	62
6.6.1	Usage restriction type and validity time	62
7	DM-MS layer 2 service description (for operation with a gateway).....	62
7.1	Introduction	62
7.2	Layer 2 architecture.....	63
7.3	Service descriptions.....	63
7.3.1	Services at the DMA-SAP	63
7.3.1.1	Services provided to layer 3	63
7.3.1.2	Service primitives at the DMA-SAP	63
7.3.1.2.1	DMA-REPORT primitive.....	63
7.3.1.2.2	DMA-UNITDATA primitive	63

7.3.2	Services at the DMC-SAP	64
7.3.2.1	Services provided to layer 3	64
7.3.2.2	Service primitives at the DMC-SAP	64
7.3.2.2.1	DMC-CONFIGURE primitive	64
7.3.2.2.2	DMC-REPORT primitive	64
7.3.3	Services at the DMD-SAP	64
7.3.3.1	Services provided to the U-plane application	64
7.3.3.2	Service primitives at the DMD-SAP	64
7.4	Parameter listing	65
8	DM-MS layer 2 protocol (for operation with a gateway)	66
8.1	Introduction	66
8.1.1	Functions of lower MAC	66
8.1.2	Functions of upper MAC	66
8.2	Interface between lower and upper MAC	66
8.2.1	Logical channels defined at the DMV-SAP	66
8.2.2	Service primitives at the DMV-SAP	66
8.2.3	PDU mapping of the logical channels at the DMV-SAP	66
8.2.4	Scrambling mechanism	67
8.2.5	PDU error detection	67
8.2.6	Modes of operation	67
8.3	Basic capabilities of the physical layer	68
8.3.1	DM-MS capabilities	68
8.3.1.1	DM only and dual mode capable MS operation	68
8.3.1.2	Dual watch capable MS operation	68
8.4	Usage of DM channel with gateway	68
8.4.1	Definition of DM channel	69
8.4.1.1	DM channel arrangement	69
8.4.1.1.1	DM channel arrangement for operation with a DM-GATE	69
8.4.1.1.2	DM channel arrangement for operation with a type 1A DM-REP/GATE	69
8.4.1.1.3	DM channel arrangement for operation with a type 1B DM-REP/GATE	69
8.4.1.2	DM channel operation	70
8.4.2	DM-MAC states	70
8.4.2.1	DM-MAC state definitions	71
8.4.2.2	DM-MS channel surveillance procedures	72
8.4.2.2.1	Initial determination of DM channel state	72
8.4.2.2.1.1	Initial determination of state of carrier	72
8.4.2.2.1.2	Determination of state of one DM channel when other DM channel is busy	73
8.4.2.2.2	Fast call set-up surveillance in idle mode	73
8.4.2.2.2.1	Fast call set-up surveillance when idle on a free carrier	73
8.4.2.2.2.2	Fast call set-up surveillance when idle on a carrier that is not free	74
8.4.2.2.3	DM-MS channel surveillance at call set-up (circuit mode call or short data message)	74
8.4.2.2.4	DM-MS channel surveillance for registration outside the registration phase	74
8.4.2.3	Master DM-MS channel maintenance procedures during a call transaction	75
8.4.2.4	Slave DM-MS channel maintenance procedures during a call	76
8.4.2.4.1	Slave MS channel maintenance during call transaction	76
8.4.2.4.2	Slave MS signal quality measurement during call transaction	76
8.4.2.4.3	Slave MS channel maintenance during reservation	76
8.4.3	Criteria for changing DM-MAC states	76
8.4.3.1	Criteria for changing DM-MAC state for master DM-MS	76
8.4.3.2	Criteria for changing DM-MAC state for slave DM-MS	76
8.4.3.3	Criteria for changing DM-MAC state for idle DM-MS	77
8.4.4	DM-MS channel monitoring procedures	78
8.4.4.1	DM channel when setting up a circuit mode call through a gateway	78
8.4.4.2	DM channel when receiving a circuit mode call set-up from a gateway	79
8.4.4.3	DM channel in occupation during a circuit mode call	79
8.4.4.4	DM channel in reservation during a circuit mode call	79
8.4.4.5	DM channel in occupation during an SDS call	79
8.4.4.6	DM channel during pre-emption signalling	80
8.4.4.7	DM channel during registration phase	80
8.4.4.8	DM channel in occupation for an unsolicited registration	80
8.4.5	Transmission of layer 3 messages by DM-MAC	81

8.4.5.1	Transmission of C-plane messages by DM-MAC.....	81
8.4.5.1.1	Transmitting DM-SETUP.....	81
8.4.5.1.2	Transmitting DM-SETUP PRES.....	81
8.4.5.1.3	Transmitting DM-CONNECT.....	81
8.4.5.1.4	Transmitting DM-DISCONNECT.....	81
8.4.5.1.5	Transmitting DM-CONNECT ACK.....	81
8.4.5.1.6	Transmitting DM-RELEASE.....	82
8.4.5.1.7	Transmitting DM-OCCUPIED.....	82
8.4.5.1.8	Transmitting DM-TX CEASED.....	82
8.4.5.1.9	Transmitting DM-TX REQUEST.....	82
8.4.5.1.10	Transmitting response to DM-TX REQUEST.....	82
8.4.5.1.11	Transmitting DM-PREEMPT.....	83
8.4.5.1.12	Transmitting response to DM-PREEMPT.....	83
8.4.5.1.13	Transmitting DM-SDS UDATA and DM-SDS DATA.....	83
8.4.5.1.14	Transmitting response to DM-SDS DATA.....	83
8.4.5.1.15	Transmitting DM-INFO.....	83
8.4.5.1.16	Transmitting DM-GSETUP.....	84
8.4.5.1.17	Transmitting DM-GTX REQUEST.....	84
8.4.5.1.18	Transmitting DM-GPREEMPT.....	85
8.4.5.1.19	Transmitting DM-GREGISTER REQUEST.....	85
8.4.5.1.20	Transmitting DM-GCANCEL ACK.....	86
8.4.5.2	Transmission of U-plane messages by DM-MAC.....	86
8.4.6	Transmission of layer 2 messages generated by DM-MAC.....	86
8.4.6.1	Transmitting DM-RESERVED.....	86
8.4.6.2	Transmitting DM-SDS OCCUPIED.....	86
8.4.6.3	Transmitting DM-TIMING REQUEST.....	86
8.4.6.4	Transmitting DM-TIMING ACK.....	86
8.4.7	General DM-MAC procedures.....	87
8.4.7.1	DM-MAC repeat transmissions.....	87
8.4.7.2	DM-MAC frame countdown procedure.....	87
8.4.7.3	Use of timers.....	87
8.4.7.4	Linearization.....	87
8.4.7.5	Fragmentation.....	88
8.4.7.6	Fill bit indication.....	88
8.4.7.7	Selection of pseudo address.....	88
8.4.7.8	Slot flag indication.....	88
8.4.7.9	Requests bitmap.....	88
8.4.7.10	Dual watch operation.....	88
8.4.7.11	Air interface encryption.....	88
8.4.7.12	Channel A or B operation.....	89
8.4.7.13	Sending short data as a transaction within a circuit mode call.....	89
8.4.7.14	SDS and registration transaction time remaining.....	89
8.4.7.14.1	SDS time remaining.....	89
8.4.7.14.2	Registration transaction time remaining.....	89
8.4.7.15	Timing change procedure.....	89
8.4.7.16	Timing change at changeover or pre-emption.....	89
8.4.7.17	Modification of slot/frame numbering by gateway.....	90
8.4.7.18	Modification of channel timing by gateway.....	90
8.5	MAC procedures for transfer of signalling messages.....	90
8.5.1	Formation of MAC PDU.....	90
8.5.2	Addressing.....	91
8.5.2.1	Transmission of message.....	91
8.5.2.1.1	Addressing in synchronization burst carrying gateway-specific message.....	91
8.5.2.1.2	Addressing in synchronization burst carrying non-gateway-specific message.....	91
8.5.2.1.3	Lifetime of pseudo SSI.....	92
8.5.2.1.4	Additional elements in synchronization burst.....	93
8.5.2.1.5	Addressing in normal burst.....	93
8.5.2.2	Reception of message.....	93
8.5.2.3	Usage of MNI.....	94
8.5.3	Use of air interface encryption.....	94
8.5.4	Fragmentation and reconstruction.....	95
8.5.4.1	Fragmentation by a DM-MS.....	95

8.5.4.2	Reconstruction by a DM-MS	96
8.5.5	Fill bit addition and deletion	97
8.5.6	Transmission and reception of messages by layer 2 unacknowledged service	97
8.5.6.1	Transmission of message	98
8.5.6.2	Reception of message	99
8.5.7	Random access protocol during occupation and reservation periods	101
8.5.7.1	Introduction	101
8.5.7.2	Procedures for master DM-MS	101
8.5.7.2.1	Indicating frames available for requests	102
8.5.7.2.2	Monitoring frames available for requests	102
8.5.7.2.3	Response to pre-emption request	102
8.5.7.2.4	Response to timing change request	103
8.5.7.2.5	Response to DM-GRELEASE message	103
8.5.7.3	Procedures for requesting DM-MS	103
8.5.8	Procedures for sending messages during registration phase	105
8.5.8.1	Procedures for registering DM-MS during registration phase	105
8.5.8.1.1	Preparing for registration access	105
8.5.8.1.2	First transmission of solicited registration request	105
8.5.8.1.3	Valid access slots	105
8.5.8.1.4	Waiting for response	105
8.5.8.1.5	Subsequent transmission of request	105
8.5.8.1.6	Abandoning registration access attempt	106
8.5.8.2	Procedures for pre-empting DM-MS during registration phase	106
8.5.8.2.1	Preparing for random access	106
8.5.8.2.2	First transmission of pre-emption request	106
8.5.8.2.3	Valid slots for pre-emption	106
8.5.8.2.4	Waiting for response	106
8.5.8.2.5	Subsequent transmission of request	107
8.5.8.2.6	Abandoning random access attempt	107
8.6	MAC procedures in traffic mode	107
8.6.1	Introduction	107
8.6.2	Criteria for transmission and reception of traffic	108
8.6.3	Change of U-plane mode	108
8.6.3.1	Call set-up by DM-MS	108
8.6.3.2	Incoming call set-up	108
8.6.3.2.1	Incoming call set-up without presence check	108
8.6.3.2.2	Incoming call set-up with presence check	109
8.6.3.3	Late entry	109
8.6.3.4	End of traffic transmission	109
8.6.3.4.1	Master DM-MS	109
8.6.3.4.2	Slave DM-MS	109
8.6.4	Exchange of information at the DMD-SAP	109
8.6.5	Stealing from circuit mode capacity	109
9	Gateway layer 3 call control procedures	110
9.1	Introduction	110
9.2	Gateway call control states	110
9.2.1	Gateway TMO call control states	110
9.2.1.1	IDLE	110
9.2.1.2	MO-CALL-SETUP	110
9.2.1.3	MT-CALL-SETUP	110
9.2.1.4	CALL ACTIVE	110
9.2.1.5	CALL DISCONNECT	110
9.2.1.6	WAIT	111
9.2.2	Gateway DM call control states	111
9.2.2.1	IDLE	111
9.2.2.2	CALL SETUP NORMAL ORIGINATING	111
9.2.2.3	CALL SETUP PRES_CHECK ORIGINATING	111
9.2.2.4	CALL SETUP TERMINATING	111
9.2.2.5	PRE-EMPTION	111
9.2.2.6	CALL ACTIVE TX OCCUPATION	111
9.2.2.7	CALL ACTIVE TX RESERVATION	111

9.2.2.8	CALL ACTIVE RX OCCUPATION.....	111
9.2.2.9	WAIT RSP OCCUPATION	111
9.2.2.10	ACK'D SHORT DATA INITIATED.....	111
9.2.2.11	UNACK'D SHORT DATA INITIATED.....	111
9.3	Layer 3 circuit mode call control procedures	112
9.3.1	Incoming call set-up from TMO	112
9.3.1.1	Incoming individual call set-up from TMO	112
9.3.1.2	Incoming group call set-up from TMO	115
9.3.1.3	Sending of DM-OCCUPIED PDU by master gateway	116
9.3.2	Outgoing call set-up to TMO.....	116
9.3.2.1	Outgoing call to TMO set-up procedures.....	116
9.3.2.2	Colliding call set-up signalling over the TMO air interface (Um)	119
9.3.2.3	Unsuccessful call set-up to TMO	119
9.3.3	Call maintenance procedures	119
9.3.3.1	End of transmission.....	119
9.3.3.1.1	Reception of DM-TX CEASED PDU from current master DM-MS	119
9.3.3.1.2	Reception of D-TX CEASED PDU from TMO	120
9.3.3.1.3	Gateway initiated DM-TX CEASED	120
9.3.3.2	Reception of D-TX INTERRUPT from TMO	120
9.3.3.3	Incoming TMO transmission during DM channel reservation.....	121
9.3.3.4	Reception of a DM request to transmit during DM channel reservation.....	121
9.3.3.4.1	Response to valid DM-GTX REQUEST (or DM-GPREEMPT) PDU.....	121
9.3.3.4.2	Response to valid DM-TX REQUEST (or DM-PREEMPT) PDU	123
9.3.3.5	TMO permission to transmit withdrawn during a call	124
9.3.3.6	TMO permission to continue with withdrawn call.....	124
9.3.3.7	SwMI initiated call continuation	125
9.3.3.8	Call modification.....	125
9.3.3.8.1	DM-MS initiated call modification	125
9.3.3.8.2	SwMI initiated call modification	125
9.3.3.9	Call disconnection.....	126
9.3.3.9.1	Reception of DM-RELEASE from current master DM-MS (or call lost).....	126
9.3.3.9.2	Call disconnection by SwMI	126
9.3.3.9.3	Expiry of call length timer.....	127
9.3.3.10	TMO call restoration.....	127
9.3.3.11	Unsolicited D-TX GRANTED PDU.....	127
9.3.3.12	Extension and end of reservation period	128
9.3.4	Gateway pre-emption procedures	128
9.3.4.1	DM-MS pre-emption of a gateway operating as master.....	128
9.3.4.1.1	New call pre-emption during call set-up	129
9.3.4.1.2	New call pre-emption during DM channel occupation.....	129
9.3.4.1.3	New call pre-emption during DM channel reservation.....	129
9.3.4.1.4	DM-MS pre-emption during DM channel occupation to continue existing call.....	130
9.3.4.1.5	DM-MS pre-emption during DM channel occupation to send short data within ongoing call	131
9.3.4.2	Pre-emption procedures during gateway slave operation.....	132
9.3.4.2.1	Transmission interrupt from TMO	132
9.3.4.2.2	Pre-emption initiated by gateway during an ongoing call	133
9.3.4.2.3	New call pre-emption by gateway	134
9.3.4.2.4	Pre-emption by another DM-MS	134
9.3.4.3	Pre-emption procedure when gateway idle	135
9.4	Layer 3 short data service procedures	135
9.4.1	Incoming SDS message from TMO.....	135
9.4.1.1	Transmission of short data message from TMO using DM unacknowledged service	135
9.4.1.2	Transmission of short data message from TMO using DM acknowledged service	136
9.4.1.3	Pre-emption of DM unacknowledged or acknowledged SDS transaction	137
9.4.1.4	Transmission of short data message from TMO during DM channel occupation.....	137
9.4.1.5	Transmission of short data message from TMO during DM channel reservation.....	138
9.4.2	Outgoing DM SDS message to TMO	138
9.4.2.1	Reception of outgoing SDS message on DM channel.....	138
9.4.2.1.1	Reception of outgoing unacknowledged SDS message on DM channel	138
9.4.2.1.2	Reception of outgoing acknowledged SDS message on DM channel	138
9.4.2.2	Reception of DM short data sent within ongoing call	139
9.4.3	SDS-TL Service.....	139

9.5	Addressing methods on TMO air interface	140
9.5.1	Receiving group call from TMO.....	140
9.5.2	Receiving individual call from TMO.....	140
9.5.3	Call set-up to TMO.....	140
9.6	Information element mapping between TM and DM PDUs.....	141
9.6.1	TMO communication type – DMO call type flag mapping	141
9.6.2	TMO call priority – DMO priority mapping.....	141
9.6.3	TMO short data type identifier – DMO short data type identifier mapping	141
9.6.4	TMO TX demand priority – DMO priority level mapping	142
10	Gateway layer 3 mobility management procedures	142
10.1	Introduction	142
10.2	Gateway MM states	142
10.2.1	MM protocol states – TMO	142
10.2.2	MM protocol states – DM.....	142
10.2.2.1	REGISTRATIONS SOLICITED.....	142
10.2.2.2	REGISTRATIONS NOT PERMITTED	142
10.2.2.3	REGISTRATIONS PERMITTED	142
10.3	Gateway MM procedures	142
10.3.1	Gateway registration to SwMI.....	142
10.3.2	Gateway MM procedures on DM	143
10.3.3	Receiving DM registration requests.....	144
10.3.3.1	Solicited registration requests	144
10.3.3.2	Unsolicited registration requests	144
10.3.4	Registration cancellation.....	145
10.3.5	Procedures for U-MM STATUS and D-MM STATUS.....	145
10.3.5.1	Procedures for sending U-MM STATUS.....	145
10.3.5.2	Procedures for receiving D-MM STATUS	146
11	Gateway U-plane converter.....	146
11.1	Introduction	146
11.2	Start of call transaction.....	147
11.2.1	Call transaction from DMO to TMO	147
11.2.2	Call transaction from TMO to DMO	147
11.3	U-plane conversion during call transaction	147
11.3.1	U-plane conversion from DMO to TMO	147
11.3.2	U-plane conversion from TMO to DM.....	148
11.4	Stopping transmission/reception	149
11.4.1	Call transaction from DMO to TMO	149
11.4.2	Call transaction from TMO to DMO	149
12	Gateway DM layer 2 service description	149
12.1	Introduction	149
12.2	Gateway DM layer 2 architecture.....	149
12.2.1	Lower layer management in layer 2.....	150
12.3	Service descriptions.....	150
12.3.1	Services at the GMA-SAP	150
12.3.1.1	Services provided to layer 3.....	150
12.3.1.1.1	Protocol control function for delivery of received message	150
12.3.1.2	Service primitives at the GMA-SAP.....	150
12.3.1.2.1	GMA-REPORT primitive.....	150
12.3.1.2.2	GMA-UNITDATA primitive	150
12.3.2	Services at the GMC-SAP	151
12.3.2.1	Services provided to layer 3.....	151
12.3.2.2	Service primitives at the GMC-SAP	151
12.3.2.2.1	GMC-CONFIGURE primitive	151
12.3.2.2.2	GMC-REPORT primitive.....	151
12.3.3	Services at the GMD-SAP	151
12.3.3.1	Services provided to the U-plane converter	151
12.3.3.2	Service primitives at the GMD-SAP.....	151
12.3.3.2.1	GMD-REPORT primitive.....	151
12.3.3.2.2	GMD-UNITDATA primitive	152
12.4	Parameter listing.....	152

13	Gateway DM layer 2 protocol.....	153
13.1	Introduction	153
13.1.1	Functions of lower MAC	153
13.1.2	Functions of upper MAC	153
13.2	Interface between lower and upper MAC.....	154
13.3	Basic capabilities of the gateway physical layer	155
13.3.1	DM-GATE capabilities.....	155
13.3.2	Type 1A DM-REP/GATE capabilities	155
13.3.2.1	Type 1A DM-REP/GATE: DM RF carrier in same sub-band as TM downlink carrier.....	156
13.3.2.2	Type 1A DM-REP/GATE: DM RF carrier in same sub-band as TM uplink carrier.....	156
13.3.2.3	Type 1A DM-REP/GATE: DM RF carrier not in either TMO sub-band.....	156
13.3.3	Type 1B DM-REP/GATE capabilities.....	157
13.3.3.1	Type 1B DM-REP/GATE: frequency usage method 1	157
13.3.3.2	Type 1B DM-REP/GATE: frequency usage method 2	158
13.4	Usage of DM channel.....	158
13.4.1	Gateway operation	158
13.4.1.1	DM-GATE operation	159
13.4.1.2	DM-REP/GATE operation.....	159
13.4.1.2.1	Type 1A DM-REP/GATE: DM RF carrier in same sub-band as TM downlink carrier	160
13.4.1.2.2	Type 1A DM-REP/GATE: DM RF carrier in same sub-band as TM uplink carrier	160
13.4.1.2.3	Type 1A DM-REP/GATE (if DM RF carrier not in TMO sub-band) or type 1B DM-REP/GATE with frequency usage method 1	161
13.4.1.2.4	Type 1B DM-REP/GATE with frequency usage method 2.....	161
13.4.2	Gateway DM-MAC states	162
13.4.2.1	Gateway DM-MAC state definitions	162
13.4.2.2	Gateway channel surveillance procedures	164
13.4.2.2.1	Channel surveillance when idle on a channel in unknown or free state (i.e. in state 0 or 1)	164
13.4.2.2.2	Channel surveillance when idle on a busy channel (i.e. in state 2, 3 or 4)	165
13.4.2.2.3	Channel surveillance when idle at DM-MS call set-up	165
13.4.2.2.4	Channel surveillance before call set-up by gateway (circuit mode call or short data).....	166
13.4.2.2.5	Channel surveillance before registration phase	167
13.4.2.2.6	Channel surveillance before registration cancellation	168
13.4.2.3	Master gateway channel maintenance during a call.....	168
13.4.2.4	Slave gateway channel maintenance during a call	168
13.4.3	Criteria for changing gateway state	169
13.4.3.1	Criteria for changing DM-MAC state for master gateway.....	169
13.4.3.2	Criteria for changing DM-MAC state for slave gateway	169
13.4.3.3	Criteria for changing DM-MAC state for idle gateway	170
13.4.4	Gateway channel monitoring procedures.....	172
13.4.4.1	DM channel during reception of fragmented DM-GSETUP message	172
13.4.4.2	DM channel during call set-up with presence check.....	172
13.4.4.3	DM channel in reservation during circuit mode call set-up	172
13.4.4.4	DM channel following circuit mode connection by gateway.....	173
13.4.4.5	Gateway as master in circuit mode occupation.....	173
13.4.4.6	Gateway as slave in circuit mode occupation	173
13.4.4.7	DM channel in reservation during a circuit mode call	173
13.4.4.8	Gateway as master in SDS occupation.....	173
13.4.4.9	Gateway as slave in SDS occupation	174
13.4.4.10	DM channel following pre-emption or changeover acceptance by gateway.....	174
13.4.4.11	DM channel following pre-emption acceptance by a master DM-MS.....	175
13.4.4.12	DM channel following pre-emption request generated by gateway	175
13.4.4.13	Gateway as master in registration phase	175
13.4.4.14	Gateway as master during registration cancellation.....	175
13.4.5	Transmission of layer 3 messages by layer 2.....	176
13.4.5.1	Transmission of C-plane messages by layer 2	176
13.4.5.1.1	Transmitting DM-SETUP and DM-SETUP PRES	176
13.4.5.1.2	Transmitting DM-CONNECT ACK.....	177
13.4.5.1.3	Transmitting DM-RELEASE	177
13.4.5.1.4	Transmitting DM-OCCUPIED.....	177
13.4.5.1.5	Transmitting DM-TX CEASED.....	178
13.4.5.1.6	Transmitting response to DM-TX REQUEST.....	179
13.4.5.1.7	Transmitting DM-PREEMPT	179

13.4.5.1.8	Transmitting response to DM-PREEMPT	180
13.4.5.1.9	Transmitting DM-SDS UDATA and DM-SDS DATA	180
13.4.5.1.10	Transmitting response to DM-SDS DATA	181
13.4.5.1.11	Transmitting DM-INFO	181
13.4.5.1.12	Transmitting response to DM-GSETUP	182
13.4.5.1.13	Transmitting response to DM-GTX REQUEST	182
13.4.5.1.14	Transmitting response to DM-GPREEMPT	183
13.4.5.1.15	Transmitting DM-GRELEASE	183
13.4.5.1.16	Transmitting response to registration request	184
13.4.5.1.17	Transmitting registration cancellation	184
13.4.5.2	Transmission of U-plane messages by layer 2	184
13.4.6	Transmission of layer 2 messages	184
13.4.6.1	Layer 2 messages sent in DMAC-SYNC PDU	184
13.4.6.1.1	Transmitting DM-RESERVED	185
13.4.6.1.2	Transmitting DM-SDS OCCUPIED	185
13.4.6.1.3	Transmitting DM-TIMING ACK	186
13.4.6.2	Gateway presence signal	186
13.4.6.2.1	Channel free	186
13.4.6.2.2	Channel in occupation	187
13.4.6.2.3	Channel in reservation	188
13.4.6.2.4	Channel in registration phase	188
13.4.7	General layer 2 procedures	188
13.4.7.1	Repeat transmissions	188
13.4.7.2	Frame countdown procedure	188
13.4.7.3	Use of timers	188
13.4.7.4	Linearization	188
13.4.7.5	Fragmentation	189
13.4.7.6	Fill bit indication	189
13.4.7.7	Use of pseudo address	189
13.4.7.8	Slot flag indication	189
13.4.7.9	Requests bitmap	190
13.4.7.10	Receiving the TM channel	190
13.4.7.11	Air interface encryption	190
13.4.7.12	Channel A or B operation	190
13.4.7.13	Sending short data as a transaction within a circuit mode call	190
13.4.7.14	SDS and registration transaction time remaining	190
13.4.7.14.1	SDS time remaining	190
13.4.7.14.2	Registration transaction time remaining	191
13.4.7.15	Modification of slot/frame numbering by gateway	191
13.4.7.16	Modification of channel timing by gateway	191
13.4.8	DM-REP/GATE procedures for DM re-transmission of DM signalling messages	192
13.4.8.1	DM re-transmission of master DM-MS signalling messages received in a DSB	192
13.4.8.1.1	General procedures	192
13.4.8.1.2	Re-transmission of DM-SETUP message	193
13.4.8.1.3	Re-transmission of DM-SDS DATA or DM-SDS UDATA message	194
13.4.8.1.4	Re-transmission of unsolicited DM-GREGISTER REQUEST	194
13.4.8.1.5	Re-transmission of other messages in a DSB when not using multi-slot regeneration	195
13.4.8.1.6	Re-transmission of other messages in a DSB during traffic transmission with multi-slot regeneration	195
13.4.8.2	DM re-transmission of master DM-MS signalling messages received in a DNB	195
13.4.8.2.1	Call transaction without multi-slot regeneration	195
13.4.8.2.2	Call transaction with multi-slot regeneration	196
13.4.8.3	Regeneration of missing repetitions on the slave link	196
13.4.8.4	DM re-transmission of messages received from a slave DM-MS	197
13.5	Layer 2 procedures for transfer of signalling messages	197
13.5.1	Formation of MAC PDU	197
13.5.2	Addressing	198
13.5.2.1	Transmission of message	198
13.5.2.1.1	Addressing in synchronization burst carrying gateway-specific message	198
13.5.2.1.2	Addressing in synchronization burst carrying non-gateway-specific message	198
13.5.2.1.3	Gateway pseudo SSI	199
13.5.2.1.4	Additional elements in synchronization burst	199

13.5.2.1.5	Addressing in normal burst.....	199
13.5.2.2	Reception of message.....	200
13.5.2.3	Usage of MNI.....	200
13.5.3	Use of air interface encryption.....	200
13.5.4	Fragmentation and reconstruction.....	201
13.5.4.1	Fragmentation by a gateway	201
13.5.4.2	Reconstruction by a gateway.....	201
13.5.4.2.1	Reconstruction by a DM-GATE.....	201
13.5.4.2.2	Reconstruction of master link message by DM-REP/GATE.....	201
13.5.4.2.3	Reconstruction of slave link message by DM-REP/GATE	202
13.5.5	Fill bit addition and deletion	202
13.5.6	Transmission and reception of messages by layer 2 unacknowledged service	202
13.5.6.1	Transmission of message	203
13.5.6.2	Reception of message.....	203
13.5.7	Random access protocol during occupation and reservation periods.....	205
13.5.7.1	Introduction.....	205
13.5.7.2	Procedures for master gateway	205
13.5.7.2.1	Indicating frames available for requests	205
13.5.7.2.2	Monitoring frames available for requests	206
13.5.7.2.3	Response to pre-emption or changeover request	206
13.5.7.3	Procedures for requesting slave gateway	208
13.5.7.3.1	Transmission of message by requesting slave gateway	208
13.5.7.3.2	Looking for response	208
13.5.7.3.3	Abandoning transmission attempt	209
13.5.8	Procedures in registration phase	209
13.5.8.1	Start of registration phase.....	209
13.5.8.2	Receiving registration requests	209
13.5.8.3	Sending response.....	209
13.5.8.4	Maintenance of registration phase.....	210
13.5.8.5	Termination of registration phase	210
13.6	Gateway procedures in traffic mode.....	210
13.6.1	Introduction.....	210
13.6.2	Criteria for transmission and reception of traffic	211
13.6.3	Change of U-plane mode	211
13.6.3.1	Call transaction from DMO to TMO.....	211
13.6.3.2	Call transaction from TMO to DMO.....	212
13.6.3.2.1	Call set-up without presence check	212
13.6.3.2.2	Call set-up with presence check	212
13.6.3.3	End of traffic transmission	212
13.6.3.3.1	Call transaction from DMO to TMO.....	212
13.6.3.3.2	Call transaction from TMO to DMO.....	212
13.6.4	Exchange of information at the GMD-SAP.....	213
13.6.4.1	Interface at gateway transmitting traffic on DMO side.....	214
13.6.4.2	Interface at gateway receiving traffic on DMO side	214
13.6.5	Stealing from circuit mode capacity	215
13.6.5.1	Transmission on STCH	215
13.6.5.2	Criteria for C-plane stealing.....	215
13.6.5.3	Reception on STCH	216
13.6.6	DM-REP/GATE procedures for DM re-transmission of DM U-plane traffic	216
13.6.6.1	Call transaction without multi-slot regeneration	216
13.6.6.2	Call transaction with multi-slot regeneration	216
14	DM PDU descriptions	217
14.1	Layer 2 PDUs sent in DSB	217
14.1.1	DMAC-SYNC PDU	217
14.1.2	DPRES-SYNC PDU	218
14.2	Layer 2 PDUs sent in DNB	220
14.3	Layer 2 information element coding	221
14.3.1	Addressing for URT = 0010 ₂ or 1000 ₂	221
14.3.2	Addressing for URT = 0011 ₂ or 1001 ₂	221
14.3.3	Addressing for URT = 0100 ₂ or 0101 ₂	221
14.3.4	Addressing for URT = 0110 ₂	221

14.3.4A	Addressing for URT = 1010 ₂	222
14.3.4B	Addressing for URT = 1011 ₂	222
14.3.5	Channel state	222
14.3.6	Channel usage	222
14.3.7	DM-REP function flag	222
14.3.8	Not used	223
14.3.9	Maximum DM-MS power class	223
14.3.10	M-DMO flag	224
14.3.11	MNI of SwMI	224
14.3.12	Number of validity time units	224
14.3.13	Registration access parameter	224
14.3.14	Registration label	225
14.3.14A	Registration phase terminated flag	225
14.3.15	Registration phase time remaining	225
14.3.16	Registrations forwarded flag	226
14.3.17	Registrations permitted	226
14.3.18	Repeater operating modes	226
14.3.19	Spacing of uplink	226
14.3.19A	System wide services not available	227
14.3.20	SwMI availability flag	227
14.3.21	Timing for DM-REP function	228
14.3.22	Two-frequency repeater flag	228
14.3.23	Usage restriction type (URT)	228
14.3.24	Validity time unit	229
14.3.25	Value of DT264	229
14.3.26	Values of DN232 and DN233	229
14.4	Messages generated by layer 2	230
14.5	Layer 3 PDUs	230
14.5.1	DM-GSETUP	231
14.5.2	DM-GCONNECT	231
14.5.3	DM-GACK	232
14.5.4	DM-GRELEASE	232
14.5.5	DM-GTX REQUEST	233
14.5.6	DM-GTX ACCEPT	233
14.5.7	DM-GPREEMPT	234
14.5.8	DM-GPRE ACCEPT	234
14.5.9	DM-GREJECT	235
14.5.10	DM-GREGISTER REQUEST	235
14.5.11	DM-GREGISTER ACCEPT	236
14.5.12	DM-GREGISTER REJECT	236
14.5.13	DM-GREGISTER CANCEL	237
14.5.14	DM-GCANCEL ACK	237
14.6	Message dependent elements coding	238
14.6.1	Gateway message subtype	239
14.6.2	Registration transaction time remaining	239
14.6.3	Reservation announced	239
14.6.4	Type of DM-GTX REQUEST	240
14.6.5	Type of registration request	240
14.7	DM-SDU elements coding	240
14.7.1	Area selection	242
14.7.2	Called party address type flag	242
14.7.3	Called party MNI	242
14.7.4	Called party SSI	242
14.7.5	Calling party TSI flag	242
14.7.6	External subscriber number	243
14.7.7	Gateway reject cause	243
14.7.8	Gateway release cause	243
14.7.9	Registration label	244
14.7.10	Registration reject cause	244
14.7.11	Request label	244
14.7.12	Serviced GSSI	244
14.7.13	Serviced GSSI flag	244

14.7.14	Type of DM-GACK.....	245
14.7.15	Value of DM-MS waiting timer.....	245
Annex A (normative): DM timers and constants in DM-MS and gateway.....		246
A.1	Layer 3 timers in DM-MS	246
A.2	Layer 3 constants in DM-MS	246
A.3	Layer 2 timers in DM-MS	247
A.4	Layer 2 constants in DM-MS	248
A.5	Maximum number of frame transmissions by DM-MAC.....	249
A.6	Layer 3 DM timers in gateway.....	249
A.7	Layer 3 DM constants in gateway	250
A.8	Layer 2 DM timers in gateway.....	250
A.9	Layer 2 DM constants in gateway.....	251
A.10	Maximum number of DM frame transmissions by gateway layer 2	253
Annex B (normative): TMO elements required for DM gateway operation.....		254
B.1	Usage of DM-MS address element.....	254
B.2	Encoding of D-MM STATUS and U-MM STATUS PDUs	254
B.2.1	D-MM STATUS	254
B.2.1.1	D-ACCEPTANCE TO START DM GATEWAY OPERATION	254
B.2.1.2	D-REJECTION TO START DM GATEWAY OPERATION	255
B.2.1.3	D-ACCEPTANCE TO CONTINUE DM GATEWAY OPERATION	256
B.2.1.4	D-REJECTION TO CONTINUE DM GATEWAY OPERATION	256
B.2.1.5	D-ACCEPTANCE TO STOP DM GATEWAY OPERATION	257
B.2.1.6	D-ACCEPTANCE OF DM-MS ADDRESSES.....	257
B.2.1.7	D-COMMAND TO REMOVE DM-MS ADDRESSES.....	258
B.2.1.8	D-COMMAND TO CHANGE REGISTRATION LABEL	258
B.2.1.9	D-COMMAND TO STOP DM GATEWAY OPERATION.....	259
B.2.2	U-MM STATUS	259
B.2.2.1	U-REQUEST TO START DM GATEWAY OPERATION	259
B.2.2.2	U-REQUEST TO CONTINUE DM GATEWAY OPERATION.....	260
B.2.2.3	U-REQUEST TO STOP DM GATEWAY OPERATION	260
B.2.2.4	U-REQUEST TO ADD DM-MS ADDRESSES	261
B.2.2.5	U-REQUEST TO REMOVE DM-MS ADDRESSES	261
B.2.2.6	U-REQUEST TO REPLACE DM-MS ADDRESS SET.....	262
B.2.2.7	U-ACCEPTANCE TO REMOVAL OF DM-MS ADDRESSES.....	262
B.2.2.8	U-ACCEPTANCE TO CHANGE REGISTRATION LABEL	263
B.2.2.9	U-ACCEPTANCE TO STOP DM GATEWAY OPERATION	263
B.3	Information element definitions	264
B.3.1	DM-MS address	264
B.3.2	DM-MS identity address type	264
B.3.3	DM-MS SSL.....	264
B.3.4	DM-MS address extension	265
B.3.5	DMO carrier	265
B.3.6	Number of DM-MS addresses.....	265
B.3.7	PDU type	265
B.3.8	Proprietary.....	265
B.3.9	Retained DM-MS address set.....	265
B.3.10	Status downlink	266
B.3.11	Status uplink.....	266
Annex C (informative): Change requests		267
History		268

Intellectual Property Rights

IPRs essential or potentially essential to the present document may have been declared to ETSI. The information pertaining to these essential IPRs, if any, is publicly available for **ETSI members and non-members**, and can be found in ETSI SR 000 314: "*Intellectual Property Rights (IPRs); Essential, or potentially Essential, IPRs notified to ETSI in respect of ETSI standards*", which is available from the ETSI Secretariat. Latest updates are available on the ETSI Web server (<http://ipr.etsi.org>).

Pursuant to the ETSI IPR Policy, no investigation, including IPR searches, has been carried out by ETSI. No guarantee can be given as to the existence of other IPRs not referenced in ETSI SR 000 314 (or the updates on the ETSI Web server) which are, or may be, or may become, essential to the present document.

Foreword

This European Standard (EN) has been produced by ETSI Technical Committee Terrestrial Trunked Radio (TETRA).

The present document is part 5 of a multi-part deliverable covering the Technical requirements for Direct Mode Operation (DMO), as identified below:

- Part 1: "General network design";
 - Part 2: "Radio aspects";
 - Part 3: "Mobile Station to Mobile Station (MS-MS) Air Interface (AI) protocol";
 - Part 4: "Type 1 repeater air interface";
 - Part 5: "Gateway air interface";**
 - Part 6: "Security";
 - Part 7: "Type 2 repeater air interface"; (Historical)
 - Part 8: "Protocol Implementation Conformance Statement (PICS) proforma specification"; (Historical)
 - Part 10: "Managed Direct Mode Operation (M-DMO)". (Historical)
- NOTE: Part 7, part 8 and part 10 of this multi-part deliverable are of status "historical" and will not be updated according to this version of the standard.

National transposition dates	
Date of adoption of this EN:	22 December 2011
Date of latest announcement of this EN (doa):	31 March 2012
Date of latest publication of new National Standard or endorsement of this EN (dop/e):	30 September 2012
Date of withdrawal of any conflicting National Standard (dow):	30 September 2012

1 Scope

The multi-part deliverable EN 300 396 defines the Terrestrial Trunked Radio (TETRA) Direct Mode Operation (DMO). It specifies the basic air interface, the inter-working between Direct Mode (DM) groups via repeaters, and inter-working with the TETRA Voice plus Data (V+D) system via gateways. It also specifies the security aspects in TETRA DMO, and the intrinsic services that are supported in addition to the basic bearer and teleservices.

The present document applies to the TETRA DMO Gateway (DM-GATE) air interface and contains the specifications of the physical, Data Link Layer (DLL) and the network layer according to the ISO model.

The specifications contained herein apply to a gateway, both as a standalone unit (DM-GATE) and also to a Direct Mode Repeater/Gateway (DM-REP/GATE) combined implementation. In the case of a combined implementation the repeater part of the gateway may be either a type 1A repeater, operating on a single RF carrier, or a type 1B repeater, operating on a pair of duplex-spaced RF carriers. They also cover the operation of a Direct Mode Mobile Station (DM-MS) with the gateway.

NOTE: The specifications for a Direct Mode type 1 repeater (either type 1A DM-REP or type 1B DM-REP) are provided in EN 300 396-4 [4].

The protocol for a DM-MS operating through a gateway is specified in clauses 5 through 8, 14 and 15. Much of this protocol is defined in the form of a "delta document" relative to the specification provided in EN 300 396-2 [2] and EN 300 396-3 [3] for direct MS-MS operation. These clauses define where the protocol in EN 300 396-2 [2] and EN 300 396-3 [3] applies without change, or where it applies with the specified amendments, replacements or additions. Where no reference to EN 300 396-2 [2] or EN 300 396-3 [3] exists, the clause should be regarded as independent.

The protocol for the gateway is specified in clauses 9 to 13, 16 and 17.

The normative annex mainly specifies the parameter values used in the protocol.

2 References

References are either specific (identified by date of publication and/or edition number or version number) or non-specific. For specific references, only the cited version applies. For non-specific references, the latest version of the reference document (including any amendments) applies.

Referenced documents which are not found to be publicly available in the expected location might be found at <http://docbox.etsi.org/Reference>.

NOTE: While any hyperlinks included in this clause were valid at the time of publication ETSI cannot guarantee their long term validity.

2.1 Normative references

The following referenced documents are necessary for the application of the present document.

- [1] ETSI EN 300 396-1: "Terrestrial Trunked Radio (TETRA); Technical requirements for Direct Mode Operation (DMO); Part 1: General network design".
- [2] ETSI EN 300 396-2: "Terrestrial Trunked Radio (TETRA); Technical requirements for Direct Mode Operation (DMO); Part 2: Radio aspects".
- [3] ETSI EN 300 396-3: "Terrestrial Trunked Radio (TETRA); Technical requirements for Direct Mode Operation (DMO); Part 3: Mobile Station to Mobile Station (MS-MS) Air Interface (AI) protocol".
- [4] ETSI EN 300 396-4: "Terrestrial Trunked Radio (TETRA); Technical requirements for Direct Mode Operation (DMO); Part 4: Type 1 repeater air interface".
- [5] ETSI EN 300 392-2: "Terrestrial Trunked Radio (TETRA); Voice plus Data (V+D); Part 2: Air Interface (AI)".

- [6] ETSI EN 300 396-6: "Terrestrial Trunked Radio (TETRA); Direct Mode Operation (DMO); Part 6: Security".

2.2 Informative references

The following referenced documents are not necessary for the application of the present document but they assist the user with regard to a particular subject area.

- [i.1] ETSI Directives: "ETSI Statutes; ETSI Rules of Procedure; ETSI Board Working Procedures; Powers and Functions of the Board; Terms of Reference of the Operational Co-ordination Group (OCG); ETSI Technical Working Procedures; ETSI Drafting rules".
- [i.2] ETSI EN 300 392-1: "Terrestrial Trunked Radio (TETRA); Voice plus Data (V+D); Part 1: General network design".
- [i.3] ETSI EN 300 396-7: "Terrestrial Trunked Radio (TETRA); Technical requirements for Direct Mode Operation (DMO); Part 7: Type 2 repeater air interface". (Historical).
- [i.4] ETSI EN 300 396-10: "Terrestrial Trunked Radio (TETRA); Technical requirements for Direct Mode Operation (DMO); Part 10: Managed Direct Mode Operation (M-DMO)". (Historical).

3 Definitions and abbreviations

3.1 Definitions

For the purposes of the present document, the terms and definitions given in the ETSI Directives [i.1] and the following apply:

call: complete sequence of related call transactions between DM-MSs and TM-MSs connected via a DM gateway

NOTE: There are two types of call, individual call or group call. An individual call is a complete sequence of related call transactions between one DM-MS and one TM-MS (or an external party accessed via the TMO network). A group call is a complete sequence of related call transactions involving DM-MSs and TM-MSs. The number of participants in a group call is not fixed. Participants may join (late entry) and leave an ongoing call.

call transaction: all of the functions associated with a complete unidirectional transmission of information

NOTE: A call is made up of one or more sequential call transactions.

called user application: user application which receives an incoming call

calling user application: user application which initiates an outgoing call

changeover: within a call, the process of effecting a transfer of the master role (and hence transmitting MS) at the end of one call transaction so that another can commence

Direct Mode Operation (DMO): mode of simplex operation where mobile subscriber radio units may communicate using radio frequencies which may be monitored by, but which are outside the control of, the TETRA TMO network

NOTE: Direct Mode Operation is performed without intervention of any base station.

Direct Mode Call Control (DMCC): layer 3 entity responsible for setting up and maintaining a call in DMO

DM channel: specific grouping of timeslots in the DM multiplex structure related to a particular DM RF carrier (i.e. DM frequency) or to a pair of duplex-spaced RF carriers

NOTE: Duplex-spaced RF carriers are used for operation with a type 1B or type 2 DM-REP or a type 1B DM-REP/GATE.

Direct Mode Mobile Station (DM-MS): physical grouping that contains all of the mobile equipment that is used to obtain TETRA DM services

NOTE: A DM-MS may have one of three roles in DMO part 5 communication:

- **master:** if the DM-MS is either active in a call transaction transmitting traffic or control data;
- **slave:** if the DM-MS is receiving traffic and/or signalling in a call;
- **idle:** if the DM-MS is not in a call.

Direct Mode Mobility Management (DMMM): layer 3 entity responsible for registration to a gateway in DMO

Dual Mode switchable Mobile Station (DU-MS): MS that is capable of operating in TETRA DMO or in TETRA TMO one mode at a time

NOTE: Only one mode can be selected at any given time and the MS is not capable of monitoring a DM RF carrier while in TMO or a TM channel while in DMO.

Dual Watch Mobile Station (DW-MS): MS that is either full dual watch MS (F-DW-MS) or idle dual watch MS (I-DW-MS)

NOTE: When idle, the MS periodically monitors both the DM RF carrier and the TMO control channel. If the MS is performing full dual watch, it is also capable of periodically monitoring the TMO control channel while in a DM call and a DM RF carrier while in a TMO call. Alternatively the MS may perform idle dual watch, in which case it need not be capable of monitoring the TMO control channel while involved in a DM activity (e.g. call) or a DM RF carrier while involved in a TMO activity (e.g. call).

Direct Mode GATEway (DM-GATE): device that provides gateway connectivity between DM-MS(s) and the TETRA TMO network

NOTE 1: The gateway provides the interface between TETRA DMO and TETRA TMO. A gateway may provide only the gateway function (DM-GATE) or may provide the functions of both a DM repeater and a DM gateway during a call (DM-REP/GATE).

NOTE 2: A gateway may have one of three roles on DMO side:

- **master:** if the gateway is either active in a call transaction transmitting traffic or control data, or is reserving the channel by means of channel reservation signalling or during the solicited registration procedure;
- **slave:** if the gateway is receiving traffic and signalling in a call from DM-MS;
- **idle:** if the gateway is not in a call.

Direct Mode REPeater (DM-REP): device that operates in TETRA DMO and provides a repeater function to enable two or more DM-MSs to extend their coverage range

NOTE: It may be either a type 1 DM-REP, capable of supporting only a single call on the air interface, or a type 2 DM-REP, capable of supporting two calls on the air interface. A type 1 DM-REP may operate on either a single RF carrier (type 1A DM-REP) or a pair of duplex-spaced RF carriers (type 1B DM-REP). A type 2 DM-REP operates on a pair of duplex-spaced RF carriers.

Direct Mode REPeater/GATEway (DM-REP/GATE): device that combines the functions of a DM repeater and a DM gateway in a single implementation and is capable of providing both functions simultaneously

NOTE: The repeater part of the combined implementation may be either a type 1A repeater, operating on a single DM RF carrier, or a type 1B repeater, operating on a pair of duplex-spaced DM RF carriers.

Direct Mode Service Centre (DM-SC): implementation of the DM store and forward entity

frequency efficient mode: mode of operation where two independent DM communications are supported on a single RF carrier or a pair of duplex-spaced RF carriers for operation with a type 2 DM-REP

NOTE: Frequency efficiency mode is not applicable to transactions through a gateway.

Full Dual Watch Mobile Station (F-DW-MS): MS that is capable of both TETRA DMO and TETRA TMO and capable of monitoring the DM RF carrier while in a TMO service and a TMO control channel while in a DM service

NOTE: When idle, the MS periodically monitors both the DM RF carrier and the TMO control channel. The MS is also capable of periodically monitoring the TMO control channel while in a DM call and a DM RF carrier while in a TMO call.

gateway: DM-GATE or DM-REP/GATE

NOTE: Generic term which describes either a pure DM-GATE or a combined implementation with a repeater (DM-REP/GATE).

Idle Dual Watch Mobile Station (I-DW-MS): MS that is capable of both TETRA DMO and TETRA TMO and when idle capable of periodically monitoring both modes

NOTE: When idle, the MS periodically monitors both the DM RF carrier and the TMO control channel. The MS need not be capable of monitoring the TMO control channel while involved in a DM activity (e.g. call) or a DM RF carrier while involved in a TMO activity (e.g. call).

logical channel: any distinct data path

NOTE: Logical channels are considered to operate between logical endpoints.

master link: communication link used for transmissions between master DM-MS and DM-REP or DM-REP/GATE

Medium Access Control (MAC) block: unit of information transferred between the upper MAC and lower MAC for a particular logical channel

NOTE: Logical channels are e.g. SCH/F or STCH. The lower MAC performs channel coding for insertion into the appropriate physical slot or half slot.

normal mode: mode of operation where only one DM communication is supported on an RF carrier or a pair of duplex-spaced RF carriers

occupation: time where a call transaction is in progress on a channel

pre-emption: transfer of the master role to the requested DM-MS

NOTE: This process may occur within a call during occupation, to set-up a new call during either occupation or reservation, or during gateway registration.

presence signal: message transmitted by a gateway or a DM-REP in order to indicate its presence on an RF carrier

radio frequency carrier (RF carrier): radio frequency channel

NOTE: This is a specified portion of the RF spectrum. In DMO, the RF carrier separation is 25 kHz.

random access: procedure used to avoid clashes when requesting permission from the current master to use the DM channel

NOTE: The request of the DM channel usage may be issued by any DM-MS that wishes to transmit traffic or short data either during occupation or reservation period.

recent user: DM-MS that was master of the call transaction immediately prior to the current master's call transaction in a call

recent user priority: service which gives the recent user a preferred access to request transmission when the current master is ceasing its call transaction in a group call

NOTE: This service is controlled by the current master.

registration phase: period of time during which a gateway is actively soliciting registration requests

reservation: time where a "channel reservation" signal is present on the channel

short data service: data service providing both user-defined short messages and predefined 16-bit messages

simplex: mode of working in which information can be transferred in both directions but not at the same time

slave link: communication link used for transmissions between the DM-REP or DM-REP/GATE and slave or idle DM-MSs

solicited registration: registration request which is made by a DM-MS during a registration phase initiated by a gateway

surveillance: process of determining the current state of the DM RF carrier when in idle mode

timebase: device which determines the timing state of signals transmitted by a DM-MS

Trunked Mode Mobile Station (TM-MS): physical grouping that contains all of the mobile equipment that is used to obtain TETRA TM services

Trunked Mode Operation (TMO): mode of operation where MSs communicate via the TETRA V+D air interface which is controlled by the TETRA Switching and Management Infrastructure (SwMI)

NOTE: This is also called V+D operation. The abbreviation "TMO" is used in the present document to pair with the abbreviation 'DMO' instead of the abbreviation "V+D". "TMO" abbreviation is not used in EN 300 392-1 [i.2] and EN 300 392-2 [5].

type 1 call: call using the protocol defined in EN 300 396-4 [4]

NOTE 1: There are two varieties of type 1 call:

- **type 1A call:** which is a call through a type 1A DM-REP;
- **type 1B call:** which is a call using the protocol for operation with a type 1B DM-REP.

NOTE 2: A DM-MS may make a type 1B call through a type 1B DM-REP. It may also make a type 1B call through a type 2 DM-REP if permitted by the DM-REP.

type 1 DM-REP: DM repeater that supports normal mode operation on the air interface

NOTE 1: There are two varieties of type 1 DM-REP:

- **type 1A DM-REP:** which operates on a single RF carrier;
- **type 1B DM-REP:** which operates on a pair of duplex-spaced RF carriers, one used as the "uplink" from DM-MSs to the DM-REP and the other used as the "downlink" from the DM-REP to DM-MSs.

NOTE 2: The protocol for operation with a type 1 DM-REP (either a type 1A or a type 1B DM-REP) is based on the protocol for normal mode in EN 300 396-3 [3].

type 2 call: call using the protocol defined in EN 300 396-7 [i.3]

NOTE: A DM-MS may make a type 2 call only through a type 2 DM-REP.

type 2 DM-REP: DM repeater that is capable of supporting frequency efficient mode operation on the air interface

NOTE: A type 2 DM-REP operates on a pair of duplex-spaced RF carriers, one used as the "uplink" from DM-MSs to the DM-REP and the other used as the "downlink" from the DM-REP to DM-MSs. The protocol for type 2 calls through a type 2 DM-REP is based on the protocol for frequency efficient mode in EN 300 396-3 [3]. (A type 2 DM-REP may also optionally offer type 1B calls using the protocol defined EN 300 396-4 [4]).

unsolicited registration: registration request which is made by a DM-MS at any time other than within a registration phase

3.2 Abbreviations

For the purposes of the present document, the following abbreviations apply:

CRC	Cyclic Redundancy Check
DCC	Direct mode Colour Code
DLB	Direct mode Linearization Burst
DM	Direct Mode
DMA	Direct mode MAC A (see note)
DMC	Direct mode MAC C (see note)
DMCC	Direct Mode Call Control entity
DMD	Direct mode MAC D (see note)
DM-GATE	Direct Mode GATEway
DMMM	Direct Mode Mobility Management entity
DM-MS	Direct Mode Mobile Station
DMO	Direct Mode Operation
DM-REP	Direct Mode REPeater
DM-REP/GATE	Direct Mode REPeater/GATEway
DM-SC	Direct Mode Service Centre
DM-SDU	Direct Mode SDU from layer 3
DMTL	Direct Mode Transport Layer (see note)
DMV	Direct mode MAC Virtual (see note)
DNB	Direct mode Normal Burst
DO-MS	Direct mode Only-Mobile Station
DSB	Direct mode Synchronization Burst
DU-MS	Dual Mode (Trunked Mode / Direct Mode) switchable Mobile Station
DW-MS	Dual Watch Mobile Station
EDSI	Encrypted DMO Short Identity
EUIV	EDSI-URTC Initialisation Value
FCS	Frame Check Sequence
FN	Frame Number
F-DW-MS	Full Dual Watch Mobile Station
GSSI	Group Short Subscriber Identity
I-DW-MS	Idle Dual Watch Mobile Station
ISSI	Individual Short Subscriber Identity
ITSI	Individual TETRA Subscriber Identity
LCH	Linearization Channel
LLC	Logical Link Control
MAC	Medium Access Control
MCC	Mobile Country Code
MM	Mobility Management
MNC	Mobile Network Code
MNI	Mobile Network Identity
mod	modulo (base for counting)
MS	Mobile Station
PDU	Protocol Data Unit
RDC	Radio Downlink Counter
RF	Radio Frequency
RSSI	Radio Signal Strength Indication
SAP	Service Access Point
SCH	Signalling Channel
SDS	Short Data Service
SDS-TL	SDS-Transport Layer
SDTI	Short Data Type Identifier
SDU	Service Data Unit
SSI	Short Subscriber Identity
STCH	Stealing Channel
SwMI	Switching and Management Infrastructure
TCH	Traffic Channel
TM	Trunked Mode
TM-MS	Trunked Mode-Mobile Station

TMO	Trunked Mode Operation
TN	Timeslot Number
TPI	Talking Party Identity
TPNI	Transmitting Party Number Identification
TSI	TETRA Subscriber Identity
TVP	Time Variant Parameter
Ud	TETRA Direct Mode air interface
Um	TETRA Trunked Mode air interface
URT	Usage Restriction Type
URTC	Usage Restriction Type Confidentiality

NOTE: Used with service primitives or service access points.

4 Overview of protocol

4.1 General

TETRA direct mode operation using a gateway offers the possibility of communication between DM-MSs, potentially out of TMO coverage, and TM-MSs on a TETRA Voice plus Data (V+D) system. The term gateway is used as a generic term to describe either a pure DM-GATE or a combined implementation with a repeater (DM-REP/GATE). In the case of a combined implementation the repeater part of the gateway may be either a type 1A repeater, operating on a single DM RF carrier, or a type 1B repeater, operating on a pair of duplex-spaced DM RF carriers. The protocol caters for all of these implementations.

The gateway re-transmits information received from the DM-MS on the Ud air interface to the TMO system on the Um air interface and vice versa.

The gateway registers and authenticates to the SwMI using its own ITSI and own security keys when applicable. Similarly the gateway uses its own identity in all signalling exchanges with the SwMI in the same way as for a normal TM-MS. If supported by both the SwMI and the gateway, the addresses of DM-MS behind the gateway can be included at layer 3 in signalling exchanges.

The method of selection of the appropriate DM RF carrier(s) is not standardized in the present document.

The gateway may generate a presence signal on the DM RF carrier after it has successfully registered and authenticated to the SwMI. The purpose of this signal is to inform any DM-MSs monitoring the RF carrier that the gateway is now present and available for service, and to provide frame and slot numbering.

The gateway is specifically addressed by a DM-MS if a connection is required to be made with the TMO system, by inclusion of the gateway address within the call set-up messages. Some DMO messages are specific to gateway operation.

NOTE 1: It is not precluded to implement other types of gateway which are not specifically addressed by a DM-MS when a connection with the TMO system is required. However such implementations are outside the scope of the present document.

When a DM-GATE is supporting a call, any recipient DM-MSs receive the signalling and traffic from the current master (which may be either the DM-GATE or a DM-MS). When a DM-REP/GATE is supporting a call, any recipient DM-MSs normally receive the signalling and traffic via the DM-REP/GATE, however a DM-MS may monitor signalling and traffic directly from a transmitting master DM-MS if it is unable to receive transmissions from the DM-REP/GATE and an idle DM-MS may pre-empt for a new call or SDS.

The gateway will normally maintain a list of valid users. If such a list is implemented then only DM-MSs which have their ITSIs contained within the list may access the gateway. The implementation of this list is outside the scope of the present document.

If individual calls are to be supported then, to enable a user in the TMO system to address an individual DM-MS, a process of DM-MS registration is needed. When it first becomes operational the gateway invites the DM-MSs to register their presence with the gateway which then forwards this information to the SwMI. If a DM-MS wishes to receive individual calls from the TMO system, it should register its presence.

Individual circuit mode calls from DMO to TMO can be supported without using DM-MS registration or the gateway informing the SwMI that it is operating as a DM gateway, and without including the DM-MS address in the TMO signalling messages. Once an individual call has been set up from DMO to TMO, the call can continue with exchanges of information while the TMO call identifier is valid e.g. until the TMO hang timer expires. After the end of the call the called TM-MS cannot call back to the calling DM-MS since it does not know the DM-MS address i.e. it only knows the address of the gateway (if supplied by the SwMI).

Similarly, without DM-MS registration and so on, a DM-MS could send a status or short data message to a TM-MS via the gateway but the TM-MS would think that the message had originated from the gateway, which would be of limited use. Even if the TM-MS did know the address of the DM-MS, it could not send a response message to the DM-MS because the SwMI could not deliver it.

If the gateway intends to support only group calls, or if it is configured to support only a single DM-MS, then it may choose not to inform the SwMI that it is operating as a DM gateway. If using this option, it may invite DM-MSs to register their presence in order that it can identify which groups to support. However, it does not send the list of DM-MSs to the SwMI and does not include DM-MS individual addresses in any of the TMO signalling messages. Therefore, the gateway appears to the SwMI to be a normal TM-MS.

NOTE 2: For group calls it is not precluded that a gateway uses different GSSI on the DMO and TMO sides and performs a translation between the two. However such implementations are outside the scope of the present document.

The present document does not provide for operation where multiple gateways using the same DM RF carrier in the same area are supporting the same group address (except for the predefined broadcast group address).

The present document does not support dual watch operation by a DM-MS operating with a gateway.

NOTE 3: It is not precluded to implement a DM-MS which operates with a gateway and also uses dual watch. However the present document does not identify or resolve any possible conflicts.

Figure 1 illustrates the protocol stacks relating to operation through a DM gateway.

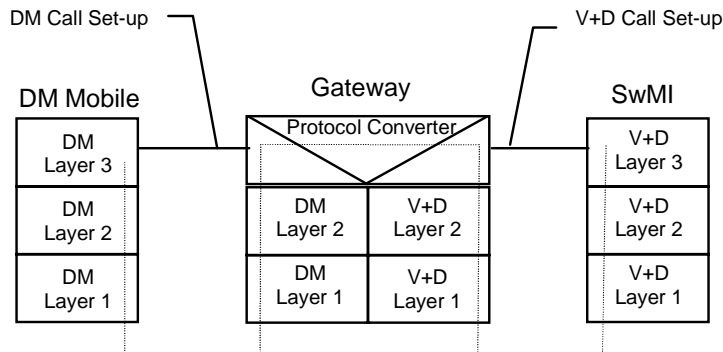

Figure 1: Protocol stack for gateway

In order to support operation with a gateway, a DM-MS needs to implement additional protocol procedures not needed for direct MS-MS operation. It is optional for a DM-MS to support operation with a gateway. If a DM-MS supports operation with a gateway then it may support operation with one or more of the following: a DM-GATE, a type 1A DM-REP/GATE or a type 1B DM-REP/GATE.

A gateway needs more physical capabilities than those needed for a DM-MS. The physical capabilities required for a gateway are described in clause 13.3.

NOTE 4: A DM-GATE is required to perform some switching functions between contiguous timeslots, though it is not required to be capable of transmitting or receiving on one RF carrier at the same time as it is either transmitting or receiving on another RF carrier (see clause 13.3.1). A DM-REP/GATE is required to perform some transmit or receive functions on a DM RF carrier simultaneously with transmitting or receiving on a TM RF carrier (see clauses 13.3.2 and 13.3.3).

The remainder of this clause 4 contains an introduction to the protocol for operation through a direct mode gateway. It is intended for information purposes only.

4.2 The DM channel

A DM channel can be perceived as being in one of four states:

- free, where there is no activity on the channel (or in the case where a gateway provides a "presence signal", when this "presence signal" indicates that the channel is free);
- occupied, where a call transaction is in progress on the channel;
- reserved, where a "channel reservation" signal is present on the channel;
- in a registration phase, where a gateway is soliciting registration requests from DM-MSs.

In addition, a DM-MS may consider the state of a DM channel to be unknown.

The actions and procedures followed by a DM-MS wishing to make a call on a DM channel through a gateway vary depending on the state of the channel.

When the channel is free, it is available for use by any DM-MS which can tune to that channel.

When a DM channel is occupied, the master DM-MS transmits signalling in DM Synchronization Bursts (DSBs) in frames 6, 12 and 18, and transmits traffic in DM Normal Bursts (DNBs) in frames 1 to 17. The gateway acts as the master when it is relaying traffic received on the Um downlink from the TMO system and acts as a slave when relaying traffic received from a master DM-MS.

A DM channel may be reserved when it has been in use for a call transaction in an individual or a group call. If the call has been routed through the gateway, then the gateway becomes master of the channel irrespective of who was master during the previous channel occupation. The gateway then transmits DSBs in frames 6, 12 and 18 on the DM channel with parameters indicating that the channel is reserved, for which group or individual it is being reserved, and for how long the channel may continue to be reserved. The DM channel may become reserved after the conclusion of each call transaction, in which case it normally stays reserved until either a changeover of the master role has been successfully achieved or until the channel reservation timer has expired.

A DM channel may also be reserved during call set-up by a DM-MS. The gateway acts as the master of the channel during call set-up by a DM-MS.

When a DM channel is in a registration phase, the gateway acts as master of the channel.

The gateway provides the frequency synchronization. If the gateway has been generating the presence signal then, if a DM-MS makes a call through the gateway, it can align its frequency reference to the gateway prior to sending the initial call set-up messages. If the presence signal or other suitable gateway signalling has not been received sufficiently recently, the DM-MS uses its own internal frequency reference to generate the transmission frequency for the initial call set-up messages. The DM-MS then aligns its frequency reference to the gateway transmissions and continues to maintain that alignment.

For operation with a DM-GATE, slave / idle DM-MSs align their frequency references to the transmissions of the current master (which may be either the DM-GATE or a DM-MS). For operation with a DM-REP/GATE, slave / idle DM-MSs normally align their frequency references to the DM-REP/GATE transmissions but may align their frequency references to a master DM-MS if necessary. At changeover or pre-emption, the new master DM-MS generates the transmission frequency using this alignment.

NOTE: For operation with a type 1B DM-REP/GATE, a DM-MS normally aligns its frequency reference to the DM-REP/GATE transmissions on the DM downlink RF carrier and then uses that reference when transmitting on the DM uplink RF carrier.

The gateway also provides the timing synchronization. If the gateway has been generating the presence signal then, if a DM-MS makes a call through the gateway, it uses the timing defined by the presence signal. If the presence signal or other suitable gateway signalling has not been received sufficiently recently, the DM-MS chooses a timing arbitrarily but the gateway may then announce a modification of the channel timing. The DM-MS then aligns its timing to the gateway transmissions.

For operation with a DM-GATE, slave / idle DM-MSs wishing to transmit align their timing to the transmissions of the current master (which may be either the DM-GATE or a DM-MS). For operation with a DM-REP/GATE, slave / idle DM-MSs wishing to transmit normally align their timing to the DM-REP/GATE transmissions and at changeover or pre-emption, a new master DM-MS normally uses the timing defined by the gateway. The exception to this is an idle DM-MS that is monitoring a via DM-REP/GATE call on the master link and wishes to pre-empt for a new call or SDS; in this case the DM-MS uses the timing defined by the current master.

4.3 DM call procedures for operation with a gateway

The procedures and sequences given in the following clauses are intended to illustrate possible scenarios and the mechanisms which the protocol may take in those circumstances for DM-MS operation with a gateway. The gateway operates on either a single RF carrier on the DM air interface (for a pure DM-GATE or a type 1A DM-REP/GATE) or a pair of duplex-spaced RF carriers (for a type 1B DM-REP/GATE); it operates on an RF carrier pair on the TMO interface. A gateway can support only one call at a time.

The procedures presented here are not exhaustive and are not intended to show every possible scenario.

In particular, the SwMI may use the protocol facilities for call set-up and channel usage for circuit mode calls in many different ways. For example:

- early or late channel assignment;
- transmission, quasi-transmission or message trunking;
- demanded layer 2 acknowledgements or repeated transmissions of Protocol Data Units (PDUs).

In the particular examples presented here the following assumptions have been made about the operation of the trunked system:

- the gateway and the TM-MS are located within the same cell and are allocated the same traffic channel (i.e. the same timeslot on the same TM carrier);
- the SwMI demands layer 2 acknowledgements rather than using repeated transmissions for individually addressed messages. In the case of a channel allocation, the acknowledgement is requested on the allocated traffic channel;
- the called MSs are paged successfully on the first attempt;
- there are no signalling collisions.

Abbreviations are used in the diagrams to represent PDUs sent within the protocol. The actual message types are as follows:

su ≡ DM-SETUP
sup ≡ DM-SETUP PRES
occ ≡ DM-OCCUPIED
txc ≡ DM-TX CEASED
cn ≡ DM-CONNECT
cnk ≡ DM-CONNECT ACK
gak ≡ DM-GACK
gtxa ≡ DM-GTX ACCEPT
gtxr ≡ DM-GTX REQUEST
gpa ≡ DM-GPRE ACCEPT (sent in DSB)
gpac ≡ DM-GPRE ACCEPT + DM-TX CEASED (sent in DNB)

gsu ≡ DM-GSETUP
 gcn ≡ DM-GCONNECT
 gprq ≡ DM-GPREEMPT
 usu ≡ U-SETUP
 utxd ≡ U-TX DEMAND
 utxc ≡ U-TX CEASED
 ucn ≡ U-CONNECT
 dsu ≡ D-SETUP
 dscn ≡ D-SETUP + D-CONNECT
 dscp ≡ D-SETUP + D-CALL PROCEEDING
 dcnk ≡ D-CONNECT + D-CONNECT ACKNOWLEDGE
 dtxg ≡ D-TX GRANTED
 dtxc ≡ D-TX CEASED
 dtgi ≡ D-TX GRANTED + D-TX INTERRUPT

Other abbreviations used are:

- gps, representing the gateway presence signal;
- tc1, tc2.... etc, representing traffic transmissions;
- lch, representing slots available for linearization;
- p?, representing slots available for pre-emption requests;
- l2a, representing a layer 2 acknowledgement;
- npd, representing a null PDU.

NOTE: In all cases an abbreviation with a (') indicates a transmission repeated once whereas an abbreviation with a (") indicates a transmission which has been repeated twice.

The gateway presence signal is a message sent by the gateway on the DM channel during calls. It may also optionally be sent on a free channel to indicate to receiving DM-MSs that the gateway is switched on and within range. It includes the gateway's 10-bit gateway address and may indicate which DM-MSs are permitted to use that gateway.

When a DM-MS makes a call through a gateway, it includes the 10-bit gateway address within the set-up message. It needs to know the correct gateway address before making the call, either by prior arrangement or by receiving the gateway presence signal. It also needs to know the gateway type (i.e. DM-GATE, type 1A DM-REP/GATE or type 1B DM-REP/GATE).

4.3.1 Constraints on the frame structure

For Direct Mode operation through a gateway the entire protocol procedure is based on a fixed frame structure and a knowledge of the current position (in time) within this structure. As shown in EN 300 396-2 [2], clause 4.5.1, the essential building blocks of the Direct Mode structure are the frame which comprises four timeslots, and the multiframe which comprises 18 frames.

In order to facilitate the Direct Mode protocol through a gateway, a number of constraints are placed on this structure, in terms of what can be transmitted in any particular slot on the DM channel:

- frame 18 is always used for synchronization purposes, and carries a DSB in both slots 1 and 3;

- frames 6 and 12 carry occupation information in a DSB in slot 3, and may carry traffic in a DNB in slot 1;
- frames 6 and 12 carry reservation information in a DSB in slots 1 and 3;
- pre-emption signalling is permitted, during occupation, in slot 3 of frames 2, 5, 8, 11, 14 and 17;
- linearization, which is carried out in a DM Linearization Burst (DLB), may be permitted in slot 3 of frame 3 during a call;
- during occupation, frames 1 to 17 usually carry traffic in slot 1 (in a DNB);
- during channel occupation by a DM-MS, the gateway may transmit a presence signal in slot 3 of frames 1, 7 and 13.

4.3.2 Setting up a call through a DM-GATE

In Direct Mode operation there are two options for call set-up: a call set-up without presence checking whereby transmission commences without explicit knowledge of the presence of any receiving DM-MS(s), and set-up with presence checking whereby a specific acknowledgement is sought from the called DM-MS before transmission commences. Call set-up with presence check only applies to individual calls.

In TMO operation there are also two methods for call set-up, dependent on the selection of hook signalling. Direct set-up does not employ hook signalling and the call is established irrespective of the presence of the user. Set-up with hook signalling requires the user to be present and to accept the call.

When setting up a circuit mode call from TMO to DMO, the gateway uses DMO call set-up without presence check for group (point-to-multipoint) calls and DMO call set-up with presence check for individual (point-to-point) calls to check the presence of the called DM-MS.

When setting up a circuit mode call from DMO to TMO, there is an additional phase to the DMO part of the call set-up using gateway specific messages, and this implicitly acts as a presence check of the gateway and the network. The subsequent DMO call set-up is without present check. On the TMO side the gateway requests direct set-up for both point-to-point and point-to-multipoint calls.

The examples presented here show the fastest possible call set-up by assuming that processing delays within the SwMI are negligible. It is also assumed that the gateway is broadcasting a presence signal and the DM-MSs have aligned their timing, on the DM channel, in a suitable manner with that signal.

4.3.2.1 Group call from TMO to DM-MS via a DM-GATE

The message sequence diagram illustrated in figure 2 shows the signalling transactions involved in setting up a group call from a TM-MS via a DM-GATE. The diagram shows the layer 3 PDUs and does not show any layer 2 signalling.

The process starts when the TM-MS sends a U-SETUP message to the SwMI which responds with a D-CONNECT and a D-SETUP message sent within the same slot. On receipt of the D-SETUP the gateway initiates a call set-up on the DM channel by sending the DM-SETUP message.

The TM-MS which originated the call will, on receipt of the D-CONNECT message, start to send its traffic which is relayed by the SwMI to the gateway and by the gateway on the DM channel once it has finished sending the DM-SETUP messages.

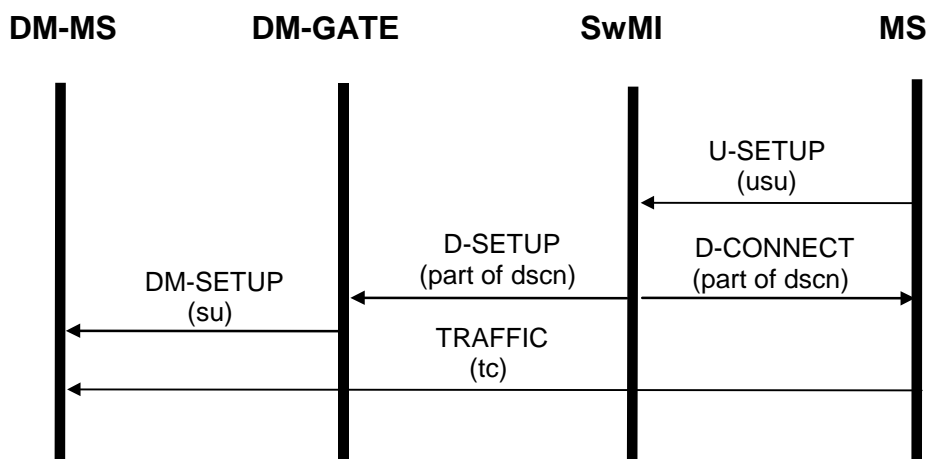

Figure 2: Message sequence chart for group call from TMO via DM-GATE

Example timings of the call set-up can be seen in figure 3.

This figure shows the slot and frame structure on both the DM RF carrier and the TMO system uplink RF carrier and the downlink RF carrier. The TM downlink RF carrier is the second line in the figure and shows the signalling messages sent by the TMO base station to the TM-MS and the gateway.

The TM uplink is a single RF carrier although it is shown twice in the figure. The first line in the diagram shows the uplink as used by the TM-MS while the third line shows the signalling on the same uplink frequency from the gateway.

The fourth line on the figure represents the DM RF carrier and shows the signalling between the gateway and the DM-MS. For clarity the RF carrier is shown as two sets of slots.

The four lines are repeated in the bottom half of the figure and are a continuation of the lines in the top half of the figure.

The figure illustrates that the DM channel has been aligned, using the slot and frame numbering broadcast in the presence signal, such that it lags the TM downlink slot 1 of the main carrier by 3 slots.

The call set-up is initiated by the U-SETUP message from the calling TM-MS in slot 1 of frame 10 on the uplink ('usu' in the figure) and the SwMI response of a D-CONNECT message and a D-SETUP message ('dscn' in the figure) is sent in slot 1 in frame 11 on the downlink. This is the fastest possible response and assumes that the SwMI has resource immediately available. These messages allocate slot 3 on the same carrier as the traffic channel.

In this example the SwMI has also, in the D-CONNECT message, demanded a layer 2 acknowledgement from the calling MS in a reserved subslot on the allocated traffic channel and this is sent by the TM-MS in slot 3 of frame 11 on the uplink. It then begins to send traffic, starting in slot 3 of frame 12.

The gateway, after receiving the D-SETUP giving slot 3 as the channel allocation re-aligns the slot and frame numbering on the DM channel (while sending the DM-SETUP messages) to suit this allocation. This can be seen in the figure on the set of slots representing the DM channel where the first DM-SETUP message marks the slot as slot 1 of frame 11 when it would otherwise have been slot 3 of frame 11. The original 3-slot lag used during the signalling phase is maintained when the traffic channel is allocated since this imposes the minimum requirements on the gateway's physical layer. As shown in this example it also avoids the need for the gateway to store and forward a burst of traffic over frame 18.

The DM-SETUP messages are sent in a sequence of synchronization bursts ('su' in figure 3, with 6 being sent in this example), using the DSB structure as given in EN 300 392-2 [5], clause 9.4.3. These synchronization bursts contain the desired slot and frame count information which defines their position in the timing structure of the 18-frame cyclic multiframe structure and achieves the necessary alignment with the allocated traffic channel on TMO.

The gateway, in this example, sends DM-SETUP messages over 2 frames and then begins relaying the traffic forwarded on the TM downlink. Note that the DM-SETUP messages are not sent in slot 2 of frames 11 and 12 in order to enable the gateway to receive the TM downlink traffic slot (since a DM-GATE is not required to be able to transmit and receive at the same time). The reliability of the DM call set-up signalling can be increased by sending more DM-SETUP messages but this could result in the loss of some of the traffic from the TM-MS.

The delay incurred in relaying the traffic from the TM-MS to the DM channel is 5 slots.

Figure 3 also illustrates the position of DM slots which are allocated to allow pre-emption requests to be made ('p?' in the figure), and the synchronization bursts denoting occupation of the DM channel ('occ' in the figure) which occur in slot 3 of frames 6 and 12 and slots 1 and 3 of frame 18 following the initial synchronization.

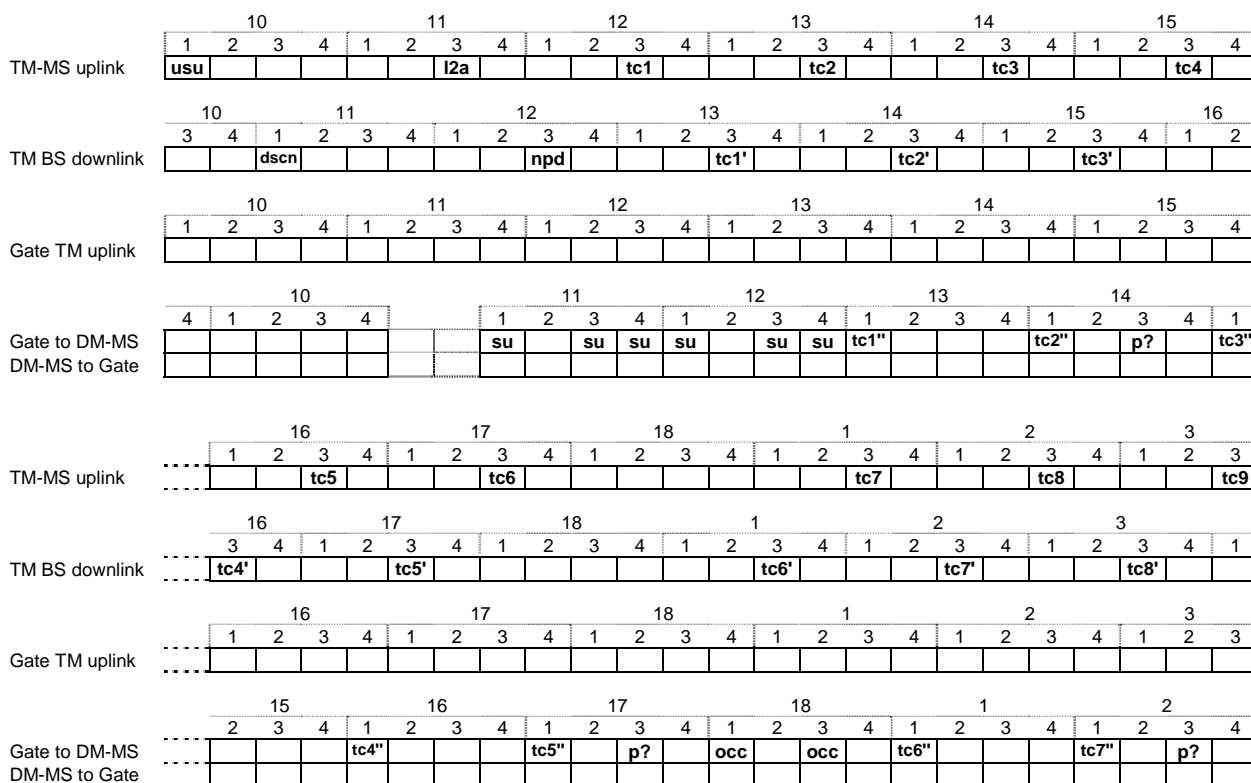

Figure 3: Timing diagram for group call from TMO via DM-GATE

4.3.2.2 Group call from DM-MS via a DM-GATE

A group call initiated by a DM-MS to a group whose members are on both the DM channel and the TMO system must take account of the response time of the TMO system. The TMO system may take some time to respond and the gateway waits for the SwMI to respond before proceeding with the call. Figure 4 illustrates the message exchanges involved in a group call set-up from a DM-MS via a DM-GATE.

The basic philosophy of the message sequence for a request originating from a DM-MS is that it comprises the request, an optional interim acknowledge, then a final acknowledgement (or rejection). In the event of a final acknowledgement then this is followed by a normal DM call set-up and traffic. This same basic message sequence philosophy of request, optional interim acknowledgement and final response, also applies to the processes of individual call set-up, call changeover and pre-emption through a gateway.

During the call set-up the gateway is master of the channel. The calling DM-MS begins the call set-up with the DM-GSETUP message which is sent on the DM channel to the gateway. The gateway then forwards a U-SETUP to the SwMI and waits for a D-CONNECT in response giving the channel allocation. While waiting for the D-CONNECT from the SwMI the gateway may send an acknowledgement to the calling DM-MS (DM-GACK) to prevent repeats of the call set-up request and then subsequently generates reservation signalling.

On receipt of the D-CONNECT the gateway sends DM-GCONNECT to the calling DM-MS which then assumes the role of master and begins the normal DM call set-up followed by traffic. The DM-SETUP messages and traffic are received by the gateway and also by DM members of the group.

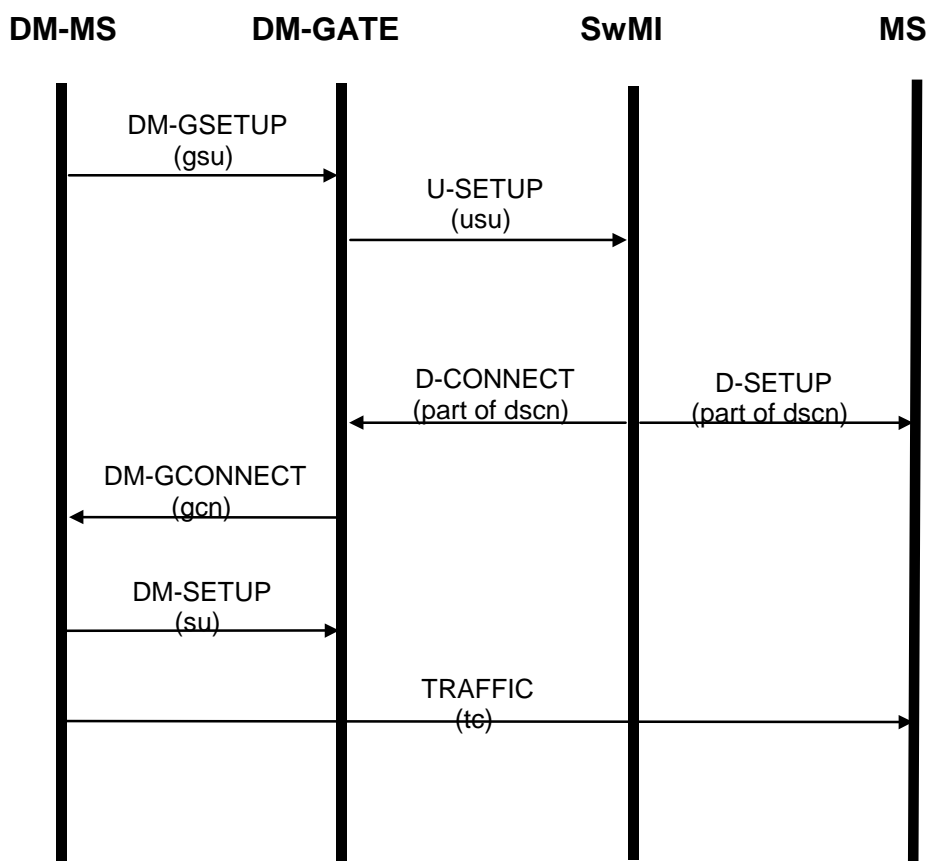

Figure 4: Message sequence chart for group call from DM-MS via DM-GATE

The timing diagram in figure 5 illustrates this call set-up. The initial alignment of the DM channel to the TM downlink slot 1 is a 3-slot lag as in the previous example.

After following the procedures given in clause 8.4.2 to ascertain the state of the channel, provided the channel is found to be in the state "free", the calling DM-MS may linearize its transmitter. It then sends the set-up request messages 'gsu' on the DM channel to the gateway. In this example, the gateway sends the U-SETUP message 'usu' on the TM uplink 3 slots later having successfully decoded the first set-up burst from the DM-MS. It is a gateway choice as to whether the gateway sends the DM-GACK interim acknowledgement to the calling DM-MS before it sends the call request to the SwMI. In this example, the call request is passed to the TMO system ('usu') without an interim acknowledgement being generated.

The SwMI has resource immediately available and responds by sending the D-SETUP and D-CONNECT messages to the TMO group members and gateway respectively in the same slot ('dscn'). It demands a layer 2 acknowledgement from the gateway in a reserved subslot on the allocated traffic channel, slot 3.

As the SwMI has responded quickly there is no need for the interim acknowledgement to the DM-MS and so the gateway responds to the calling DM-MS with the DM-GCONNECT message. This message is also used to re-align the slot and frame numbering on the DM channel. Again, as in the previous example, the same 3-slot lag is maintained between the DM channel and the allocated TM traffic channel.

In the meantime, in the absence of genuine traffic, the gateway generates null PDUs on the TM uplink. After receipt of the DM-GCONNECT from the gateway, the DM-MS assumes the role of master, but follows the new timing established by the gateway, and generates DM-SETUP messages on the DM channel to alert the DM members of the group. It then proceeds to send its traffic which is relayed by the gateway on the TM uplink 3 slots later and by the SwMI on the TM downlink a further 2 slots after this.

In this example the slot and frame alignment on the DM channel has been chosen to lag that on the TM traffic channel, as was done for the example in figure 3. This means that, for traffic flowing from the TM channel to the DM channel, the frame 18 alignment is such that there is no need for the gateway to store a burst of traffic. However this same frame alignment means that, for traffic flowing from the DM channel to the TM channel, the gateway is required to store one burst of traffic across the frame 18 boundary. This may be seen in figure 5 where the traffic burst tc2 sent in slot 1 of frame 17 on the DM channel cannot be relayed as usual 3 slots later on the TM uplink as this lies inside a frame 18. The gateway is thus forced to store the traffic burst and to relay it in the next available frame (frame 1). It is recommended that the frame numbering be chosen initially as in the example in figure 5, with the DM channel numbering lagging that of the TM downlink, and that the numbering remain consistent with change-over.

The figure also illustrates the position of DM slots which are allocated to allow pre-emption requests to be made ('p?' in the figure), and the synchronization bursts denoting occupation of the DM channel ('occ' in the figure) which occur in slot 3 of frames 6 and 12 and slots 1 and 3 of frame 18 following the initial synchronization. It also shows, in slot 3 of frame 1 on the DM channel, the gateway presence signal which is transmitted by the gateway in slot 3 of frames 1, 7 and 13 during occupation by a DM-MS as master.

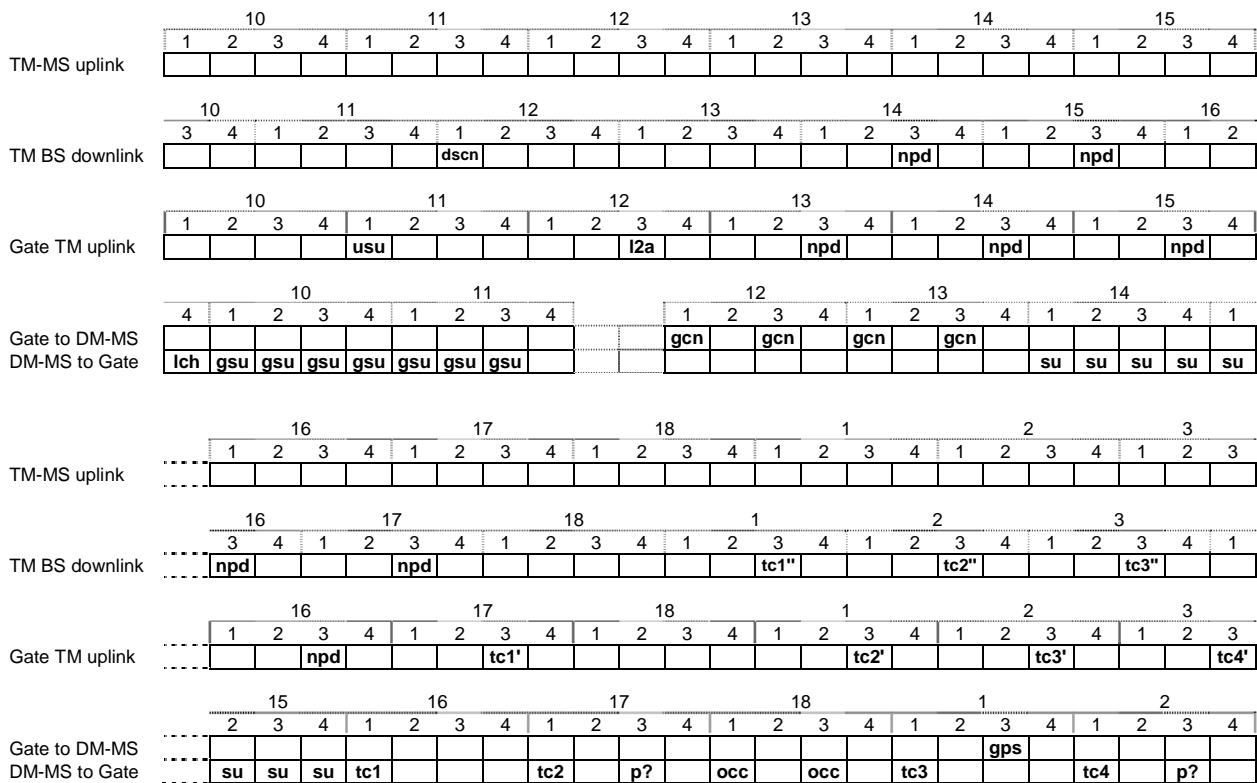

Figure 5: Timing diagram for group call from DM-MS via DM-GATE

4.3.2.3 Individual call from TM-MS to DM-MS via a DM-GATE

The message sequence chart in figure 6 illustrates the signalling involved in setting up an individual call from a TM-MS to a DM-MS on the DM channel, via a DM-GATE.

The TM-MS makes its request using the U-SETUP message which is acknowledged by the SwMI with a D-CALL PROCEEDING PDU. The gateway, having received the call set-up request from the SwMI (D-SETUP), sends the DM-SETUP PRES PDU on the DM channel to page the called DM-MS.

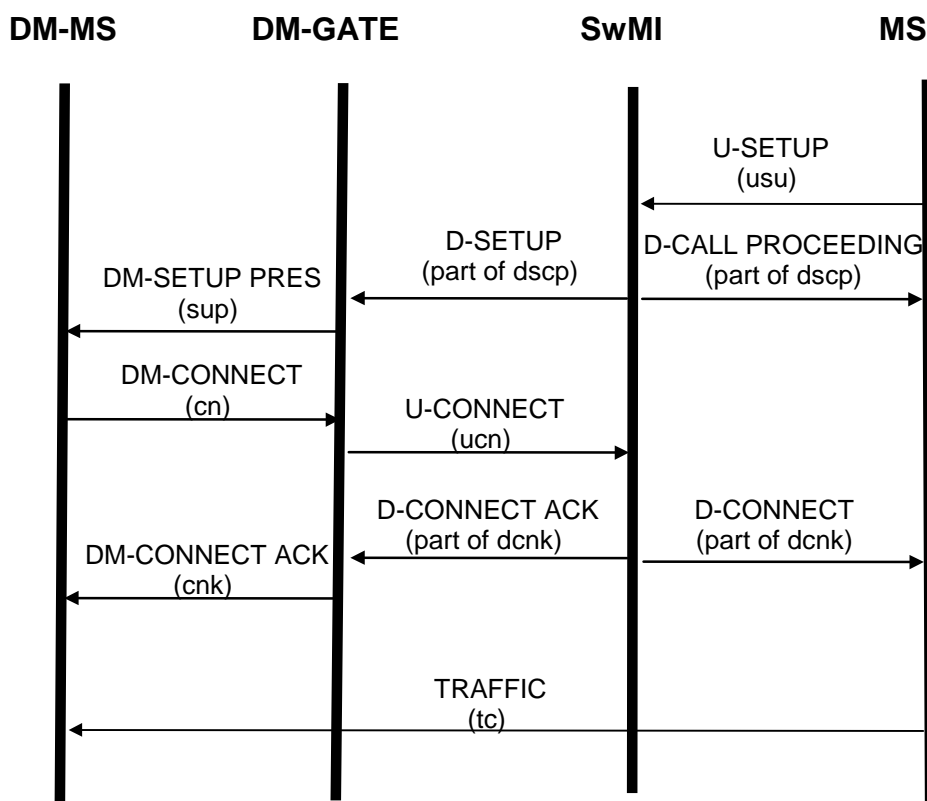

Figure 6: Message sequence chart for individual call from TMO via DM-GATE

This DM-MS, if available and willing to accept the call, responds with the DM-CONNECT message. The gateway forwards a U-CONNECT to the SwMI which allocates a traffic channel with the D-CONNECT and D-CONNECT ACKNOWLEDGE messages. The gateway uses the reservation message to reserve the DM channel while it waits for the SwMI response.

On receipt of the D-CONNECT the calling TM-MS commences to send its traffic.

On receipt of the D-CONNECT ACKNOWLEDGE the gateway sends DM-CONNECT ACK to the called DM-MS to enable it to prepare for receipt of traffic and then forwards the traffic received from the SwMI.

Example timings involved with the individual call set-up can be seen in figure 7.

The initial alignment between the DM channel and the TMO control channel (slot 1) is the 3-slot lag. The U-SETUP PDU is sent by the calling TM-MS in slot 1 of frame 10 ('usu' in the figure). The SwMI response of D-CALL PROCEEDING to the calling MS and the page to the called party (D-SETUP) are sent in the control channel slot in downlink frame 11 ('dscp'). The D-SETUP demands a layer 2 acknowledgement from the gateway which is sent in frame 11 on the TM uplink.

The gateway then sends the DM-SETUP PRES message on the DM channel to page the called DM-MS. This message ('sup') is sent in 6 slots over 2 frames. The gateway then listens for the DM-CONNECT response ('cn' in the figure). On receipt of this response the gateway then responds to the SwMI with a U-CONNECT message. Note that, in this example, direct call set-up is used on the SwMI side. The gateway uses call set-up signalling with presence check on the DMO side in order to ascertain that the called DM-MS is actually present before it responds to the SwMI.

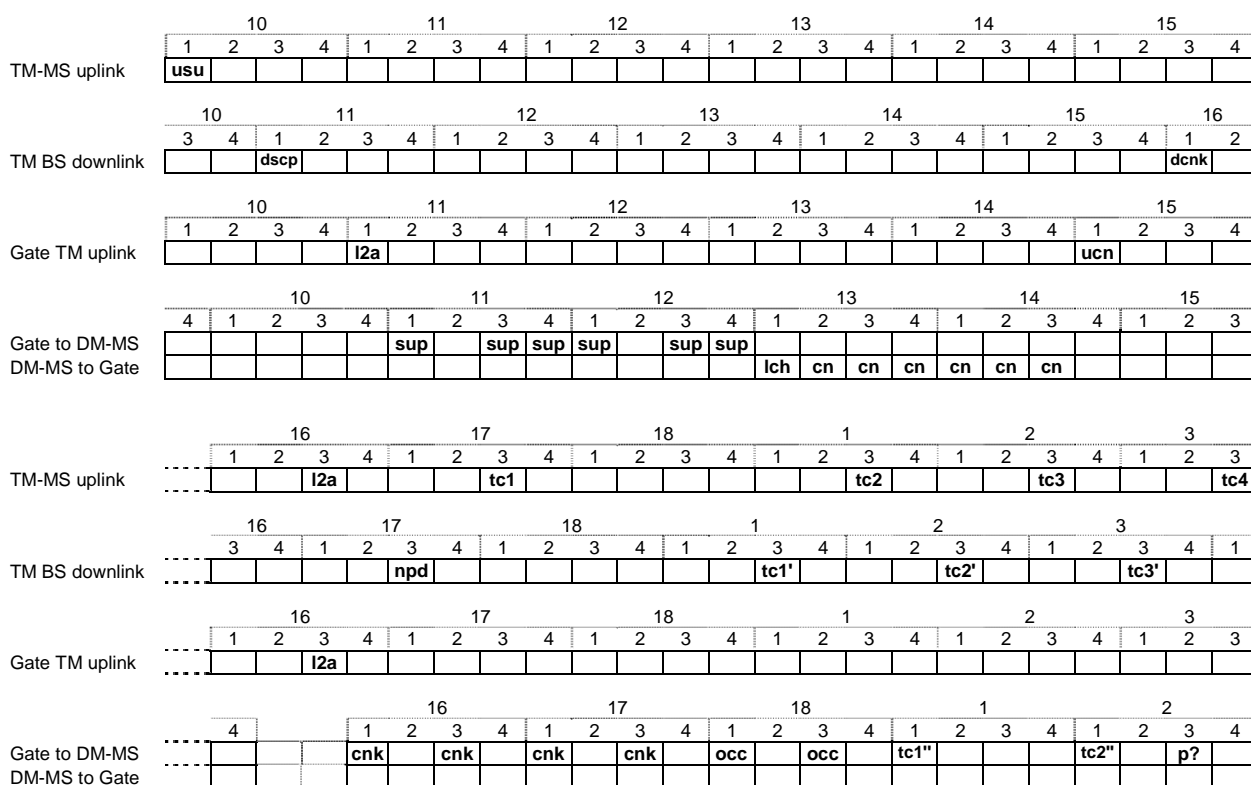

Figure 7: Timing diagram for individual call from TM-MS via DM-GATE

The SwMI then sends a D-CONNECT and a D-CONNECT ACKNOWLEDGE ('dcnk' in the figure) to the calling party and the gateway respectively, giving the traffic channel allocations, in this case slot 3 on the same carrier. Both the TM-MS and the gateway are requested to generate layer 2 acknowledgements to the SwMI and these are sent in different halves of the same slot as determined by the SwMI. The gateway then informs the called DM-MS of the successful connection using a DM-CONNECT ACK ('cnk'), at the same time re-defining the slot numbering to achieve a suitable alignment with the allocated channel on the TMO system. This is done by setting the slot number and frame number elements appropriately. As before a 3-slot lag is used.

The calling TM-MS, after receipt of the D-CONNECT, may then transmit traffic ('tc' in the figure) in the allocated channel (slot 3). This is forwarded to the gateway 2 slots later on the SwMI downlink ('tc') and then to the DM-MS on the DM channel ('tc'') a further 3 slots later.

In this example, the SwMI responds to the U-CONNECT from the gateway in the next frame. It is possible that the SwMI may not respond so swiftly. In this case, during the call set-up phase, between DM-CONNECT and DM-CONNECT ACK, the gateway generates a reservation signal, reserving the channel and optionally inviting pre-emption requests.

Figure 7 also illustrates the position of DM slots which are allocated to allow pre-emption requests to be made ('p?' in the figure), and the synchronization bursts denoting occupation of the DM channel ('occ' in the figure) which occur in slot 3 of frames 6 and 12 and slots 1 and 3 of frame 18 following the initial synchronization.

4.3.2.4 Individual call from DM-MS to TM-MS via a DM-GATE

The sequence diagram shown in figure 8 illustrates the signalling involved in setting up an individual call from a DM-MS to an MS in the TMO system. Figure 9 illustrates the timing of the call set-up.

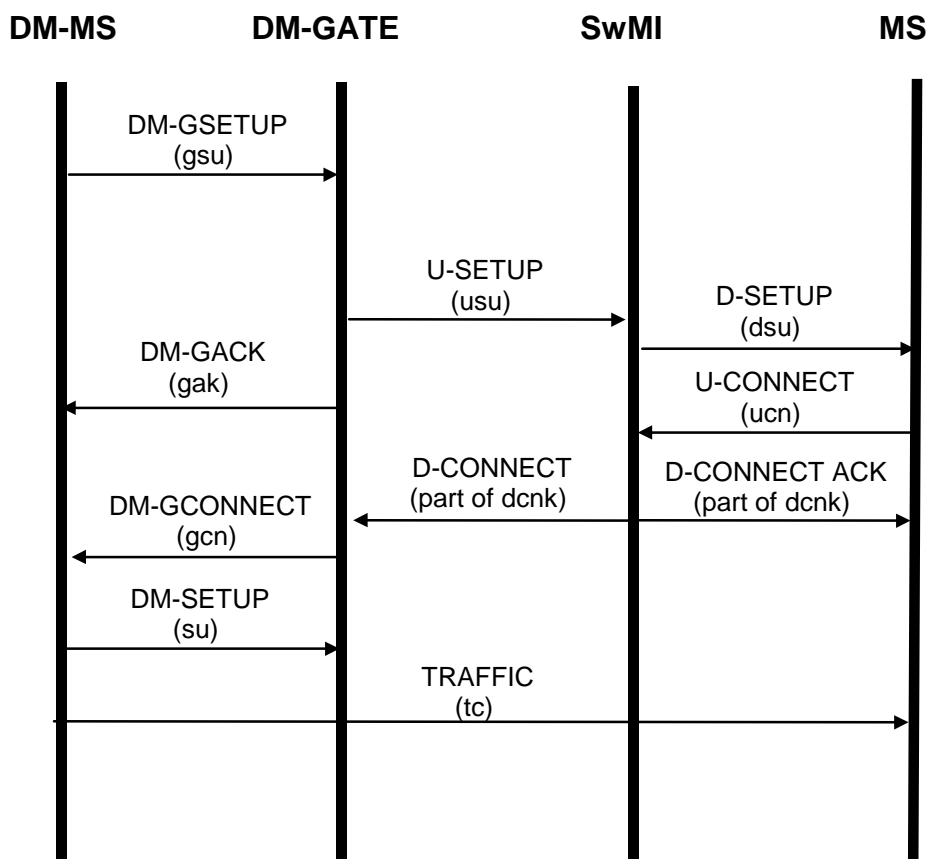

Figure 8: Message sequence chart for individual call from DM-MS via DM-GATE

The process starts when the DM-MS sends the DM-GSETUP call request ('gsu' in figure 9) having determined the frame and slot numbering on the link established by the gateway presence signal. The gateway forwards the call request to the SwMI which in turn pages the required TM-MS. It is a gateway choice as to whether the gateway sends the interim acknowledgement to the calling DM-MS before it sends the call set-up to the SwMI. In this example, the call request is passed to the TMO system ('usu') before the interim gateway acknowledgement ('gak') is sent to the DM-MS.

On receipt of a U-CONNECT from the called TM-MS the SwMI sends a D-CONNECT and a D-CONNECT ACKNOWLEDGE ('dcnk' in the figure) to the gateway and the TM-MS respectively giving the channel allocation, in this example, slot 3 on the same carrier. The gateway then sends the final acknowledgement, DM-GCONNECT ('gcn'), to the calling DM-MS redefining the slot numbering as necessary for alignment with the TM channel. In this case, the DM-GCONNECT message delays the slot numbering by two slots, maintaining the 3-slot lag between DM and the TM channel. The gateway also sends null PDUs to the SwMI until the calling DM-MS is ready to send traffic.

After receipt of the final acknowledgement, the calling DM-MS becomes master of the DM channel, and then follows the standard DM call set-up procedures, sending DM-SETUP messages followed by traffic.

In this instance, the chosen slot and frame alignment between the TM traffic channel and the DM channel necessitates the gateway storing a burst of traffic over frame 18. The traffic sent on the DM channel in slot 1 of frame 17 cannot be sent 3 slots later on the TM uplink as this is frame 18 and so must be held for one frame period to be sent later in slot 3 of frame 1.

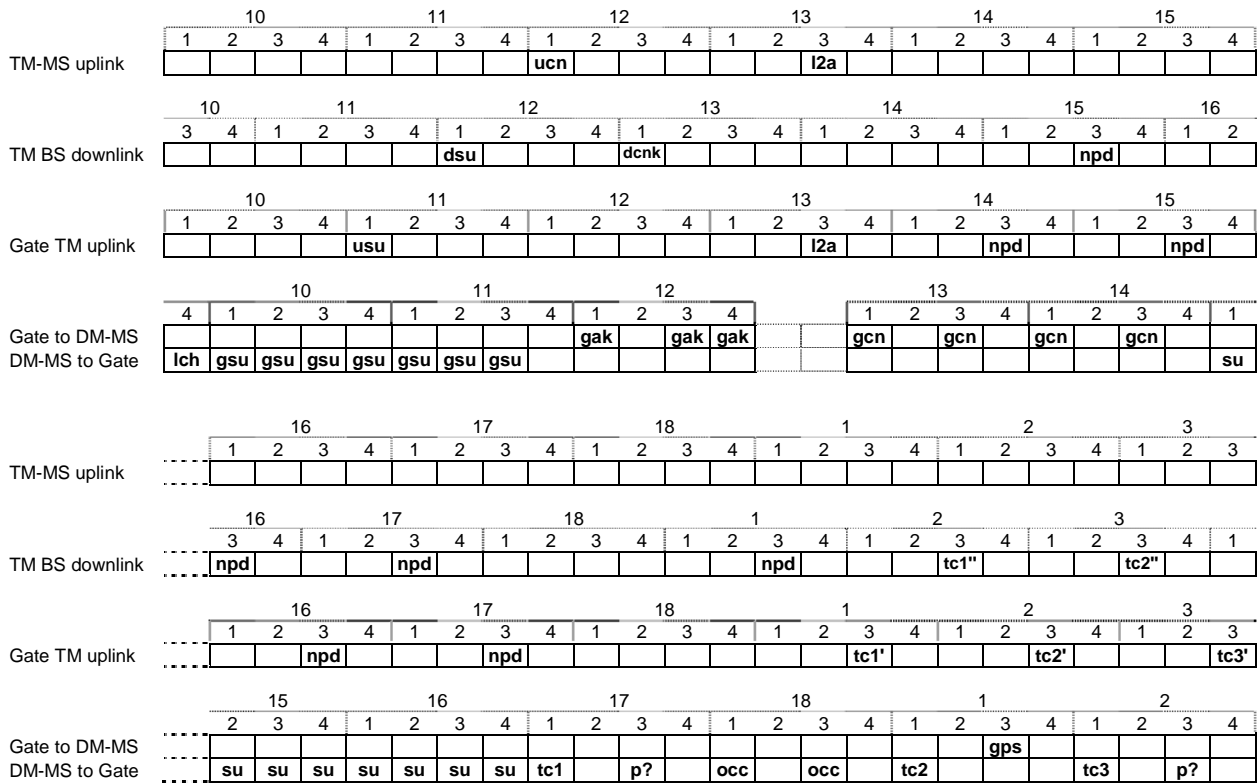

Figure 9: Timing diagram for individual call from DM-MS to TM-MS via DM-GATE

4.3.3 Changeover in a call via a DM-GATE

In a DM call, each call transaction constitutes a separate transmission, with a designated master and slave(s) for each call transaction. Similarly, in TMO, each call transaction also comprises a separate transmission. The procedure for terminating one call transaction and starting another during a call is termed changeover and is illustrated by the diagram in figure 10.

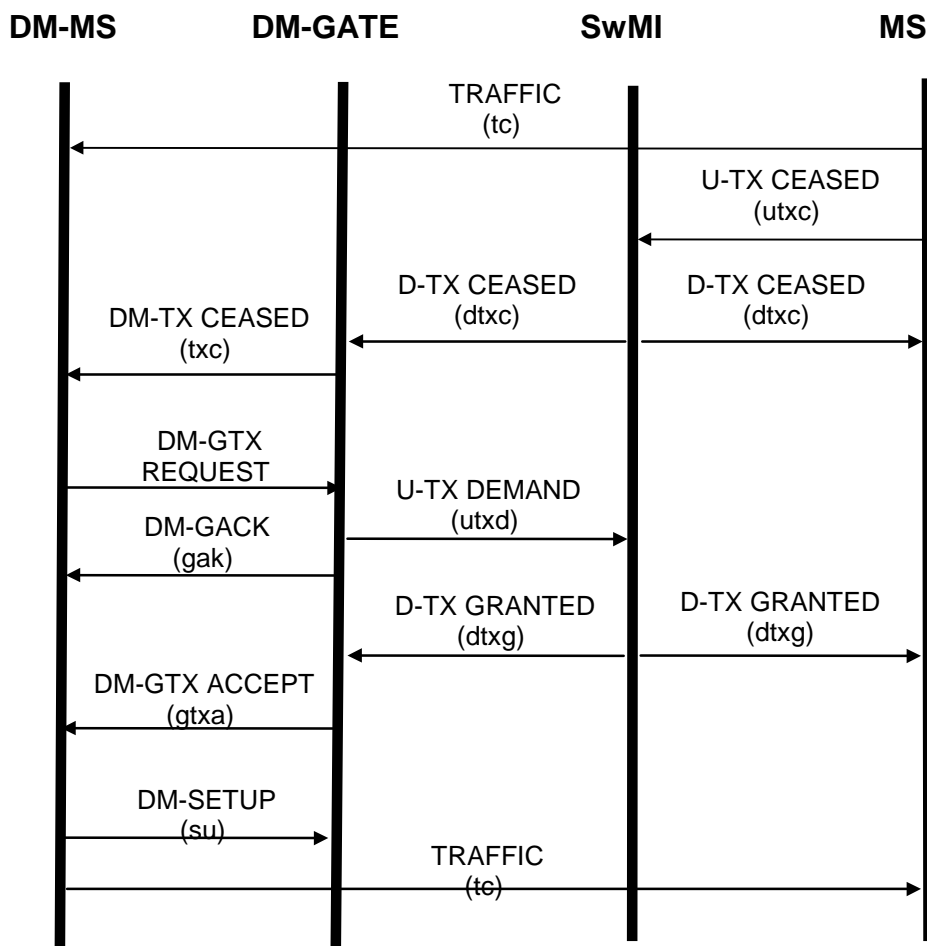

Figure 10: Message sequence chart for changeover from TM-MS to DM-MS

In this example, traffic is being sent in an individual call by an MS in the TMO system. In order to effect a changeover the talker (or sender) first indicates that its call transaction has come to an end, using a U-TX CEASED message. The SwMI informs the gateway using a D-TX CEASED message and the gateway in turn informs the DM-MS using the DM-TX CEASED message.

In this example the DM-MS wishes to transmit and requests permission from the gateway by sending the DM-GTX REQUEST message. Receipt of this changeover request message may optionally be acknowledged by the gateway with the DM-GACK message.

The gateway forwards the request to the SwMI using the U-TX DEMAND message. The SwMI then, in this example, gives transmit permission to the gateway and receive permission to the TM-MS at the same time using D-TX GRANTED messages.

On receipt of this permission from the SwMI, the gateway as master then surrenders the channel to the DM-MS using the DM-GTX ACCEPT message. The requesting DM-MS now becomes master, sending the DM-SETUP message followed by traffic.

Figure 11 illustrates the timing involved in the changeover process. The TM-MS indicates that its call transaction has come to an end, using a U-TX CEASED message ('utxc' in figure 11). The SwMI informs the gateway and acknowledges the TM-MS using D-TX CEASED messages and requests a layer 2 acknowledgement from both parties. The gateway in turn informs the DM-MS using the DM-TX CEASED message ('txc' in figure 11). The changeover request message ('gtxr' in the figure) in this example is sent by a requesting mobile in the next available slot 3 on the DM channel following reception of the txc, assuming the gateway makes slot 3 of frame 7 available for random access in the DM-TX CEASED.

The gateway, in this example, then makes the transmission request to the SwMI ('utxd') before acknowledging receipt of the changeover request message on the DM channel ('gak' in frame 8).

In this example, the SwMI gives transmit and receive permission to the gateway and the TM-MS respectively using D-TX GRANTED messages ('dtxg'), demanding a layer 2 acknowledgement from both parties. Slot 3 is still used as the traffic channel.

On receipt of this permission from the SwMI, the gateway then surrenders the channel to the DM-MS using a series of final acknowledgement messages ('gtxa' in the figure). On receipt of the changeover acknowledgement messages, the requesting DM-MS now transmits a sequence of set-up messages as master ('su' in the figure).

Note that, after the transmission grant from the SwMI, the gateway sends null PDUs until traffic is received from the DM-MS.

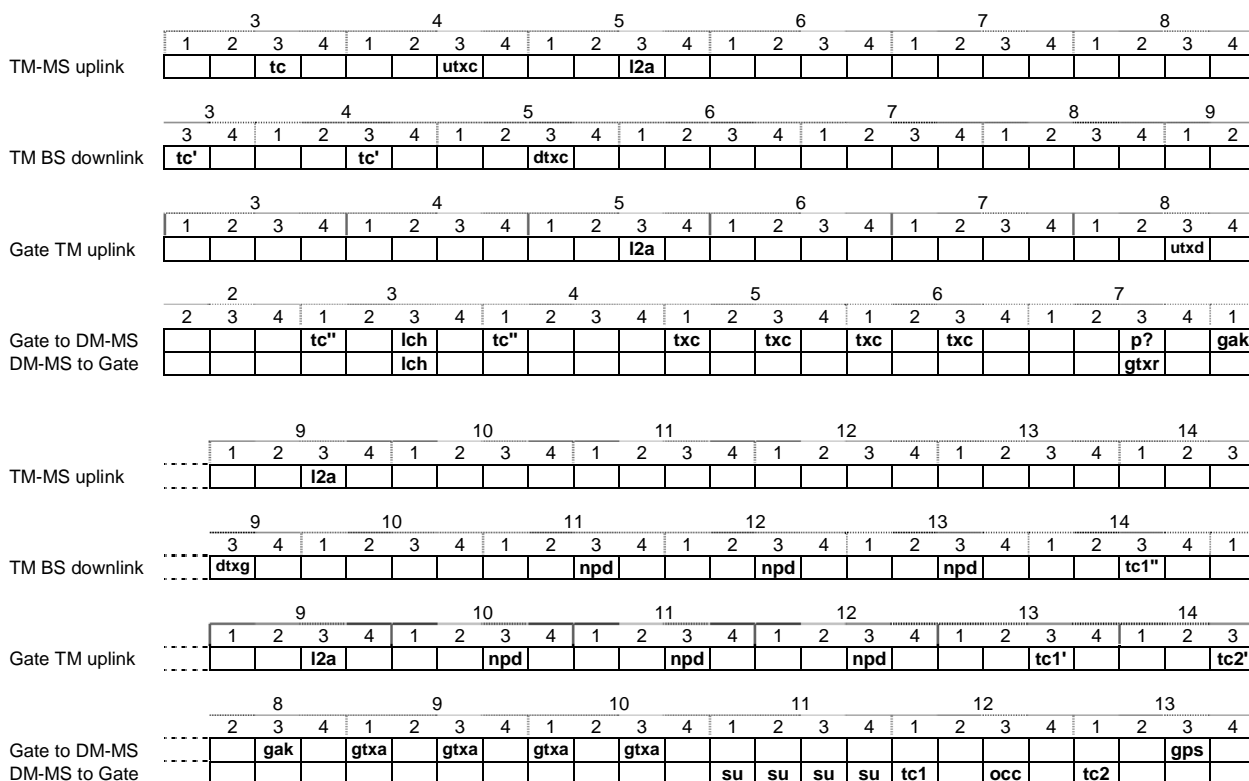

Figure 11: Timing diagram for a changeover of an individual call from TM-MS to DM-MS

4.3.4 Pre-emption of a direct mode call through a DM-GATE

During a call through a gateway, a DM-MS, who may or may not be involved in the current call may wish to access the DM channel for a priority reason such as an emergency. In this case a mechanism for pre-empting the already occupied channel exists. It is illustrated in figure 12 which shows the case where a transmitting TM-MS operating through the gateway is pre-empted by a DM-MS wishing to transmit in the same call.

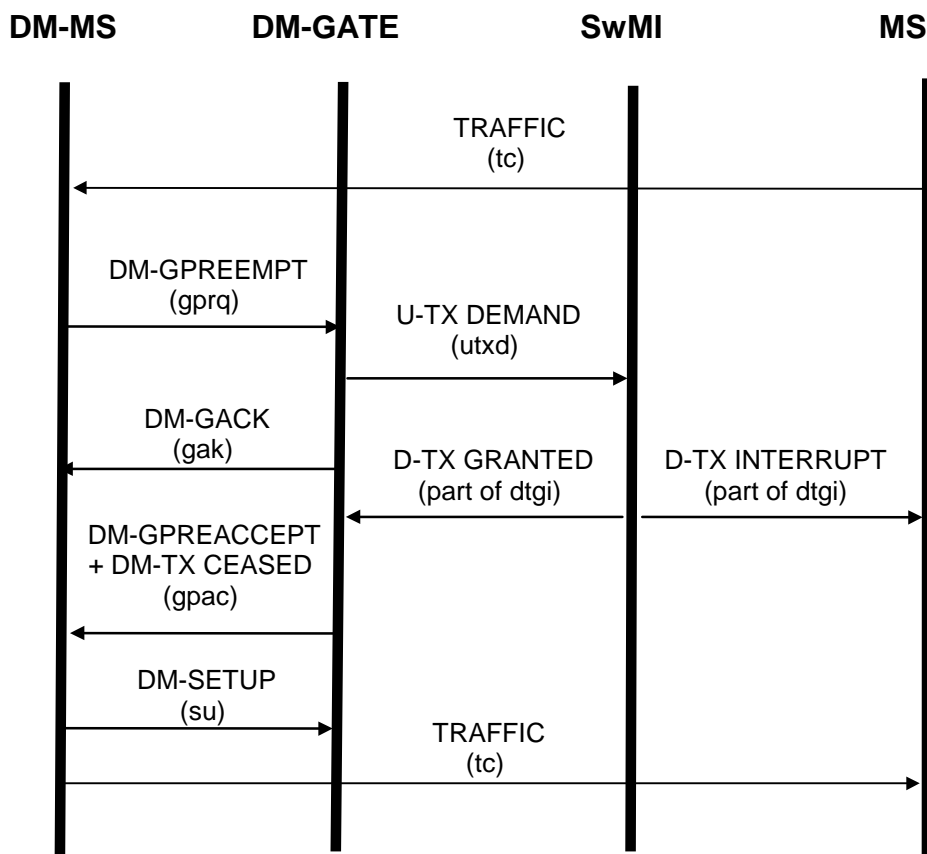

Figure 12: Message sequence chart for pre-emption of TM-MS by DM-MS via DM-GATE

In this example a TM-MS is sending traffic which is being relayed by the gateway on the DM channel with the gateway acting as the master.

To effect the pre-emption, the DM-MS sends a DM-GPREEMPT message. When the gateway successfully decodes the pre-emption request, assuming it is a valid request, it sends a transmission demand to the SwMI using a U-TX DEMAND PDU with the priority set appropriately. It is a gateway choice as to whether it acknowledges receipt of the pre-emption request using the interim acknowledgement message (DM-GACK) before sending the U-TX DEMAND request to the SwMI.

The SwMI instructs the transmitting TM-MS to stop sending using the D-TX INTERRUPT message and, in this example, simultaneously grants transmit permission to the gateway using the D-TX GRANTED message. On receipt of this message from the SwMI, the gateway then surrenders the channel to the DM-MS using the DM-GPRE ACCEPT message. It also sends the DM-TX CEASED message.

The requesting DM-MS then sends the DM-SETUP message as master followed by traffic.

Figure 13 illustrates the timing of the pre-emption procedure.

To effect the pre-emption, the DM-MS transmits a pre-emption request message ('gprq' in the figure) at an appropriate position in the DM frame structure. During occupation, pre-emption is allowed only in slot 3 of frames 2, 5, 8, 11, 14 and 17. On receipt of the pre-emption request the gateway sends the U-TX DEMAND message to the SwMI in slot 3 of frame 7 on the TM uplink. This is the first possible frame as slot 3 of frame 6 would not have allowed sufficient time to decode the pre-emption request received in the preceding slot.

In this example the SwMI instructs the transmitting TM-MS to stop sending and simultaneously grants transmit permission to the gateway ('dtgi' in the figure), demanding a layer 2 acknowledgement from both parties.

The gateway then informs the pre-empting DM-MS of this using the DM-GPRE ACCEPT message. This is sent in the traffic slots (slot 1) of frames 8 and 9 on the DM channel along with a DM-TX CEASED message ('gpac'). The DM-GPRE ACCEPT message is repeated in slot 3 of both frames for increased reliability ('gpa').

On receipt of these acknowledgement messages, the requesting DM-MS now transmits a sequence of set-up messages as master ('su' in the figure).

Note that, after the transmission grant from the SwMI, the gateway sends null PDUs until traffic is received from the DM-MS.

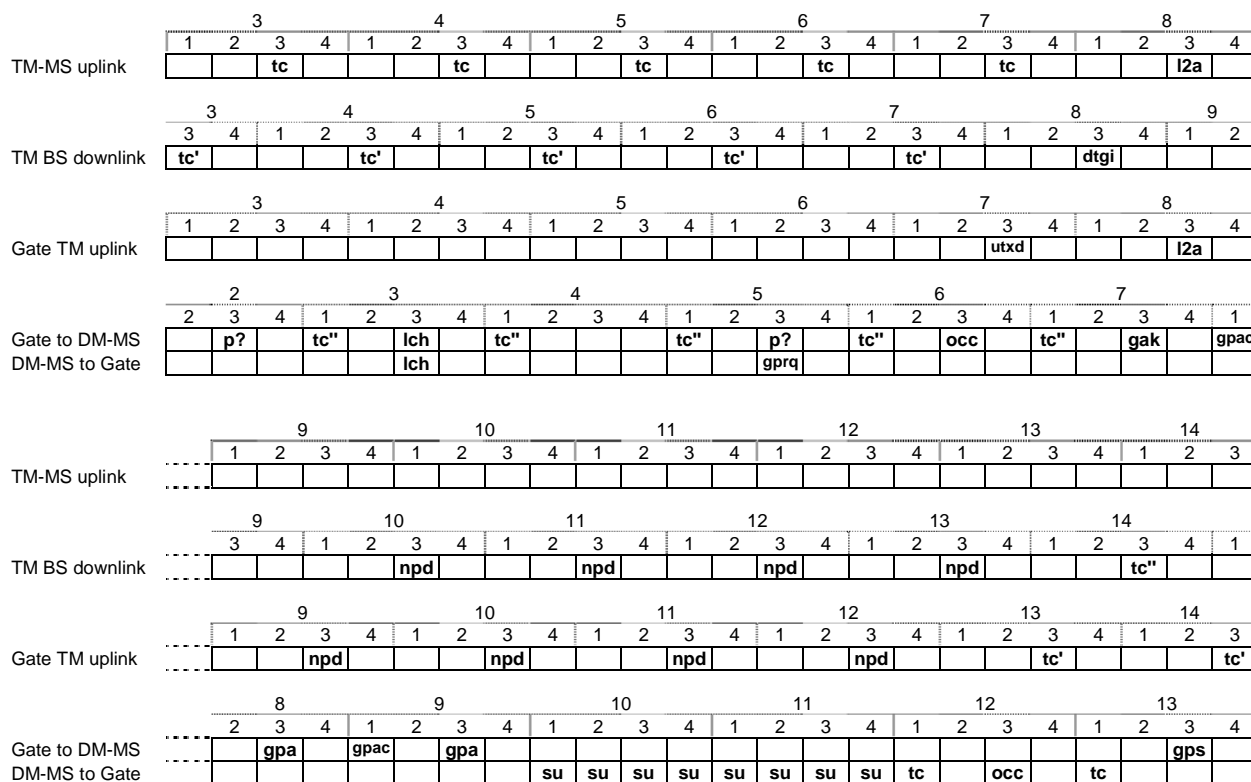

Figure 13: Timing diagram for pre-emption of a call through a DM-GATE

4.3.5 Short Data Service through a gateway

The protocol for the DM Short Data Service when operating with a gateway is similar to that defined in EN 300 396-3 [3], clause 6.3. The short data messages may be sent in any of the same four modes and the PDUs are the same.

For operation with a gateway there are a number of differences. Short data messages are only acknowledged at layer 2 on the TMO system. For consistency, when a DM-MS sends a short data message through a gateway using the acknowledged service, the acknowledgement is generated by the gateway as the equivalent of the TMO layer 2 acknowledgement.

The DM-MS sends the short data message to the gateway which then generates an acknowledgement if required. The gateway then forwards the short data message to the SwMI using the appropriate procedures defined in EN 300 392-2 [5].

Short data messages may also be sent from a TMO user to a DM-MS (or DM-MSs) via the gateway. The gateway receives the short data message from the SwMI and generates a layer 2 acknowledgement if required. It then forwards the short data message on the DM channel to the DM-MS(s).

4.3.6 Group call from DM-MS via DM-REP/GATE

It is possible for a DM gateway to be part of a combined implementation with a DM repeater, providing the gateway and repeater functions simultaneously as a DM-REP/GATE. This poses some additional considerations in regard to timing of the various transmissions in order to avoid the need for transmitting while receiving in the same sub-band.

In the example illustrated in figure 14 a group call is being set up by a DM-MS via a type 1A DM-REP/GATE. The DM RF carrier lies in the TM downlink sub-band. The initial timing has been established by the gateway presence signal such that slot 1 of the DM master link aligns with slot 1 of the TM downlink. This alignment minimizes the conflict between requirements to transmit on the DM RF carrier while receiving on the TM downlink frequency.

The call set-up is established by the calling DM-MS, as a slave, sending a number of DM-GSETUP messages ('gsu') to the gateway, 7 being sent in this example. The gateway forwards a U-SETUP message ('usu') on the TM uplink, receiving in response a D-CONNECT message, sent in the same slot as the D-SETUP message ('dscn') and allocating slot 3 on the same carrier as the traffic channel. The SwMI also demands a layer 2 acknowledgement from the gateway. The principle established earlier is followed in that the call set-up on the DM channel is delayed until the TMO system has responded. In this case it has responded quickly and the gateway returns the DM-GCONNECT ('gcn') on the DM slave link to the calling DM-MS, having re-aligned the timing to suit the allocated slot 3 traffic channel.

The DM-MS then generates the set-up signalling ('su') as master which is then repeated by the gateway on the DM slave link. The calling DM-MS waits for the repeated transmissions to be completed before it sends traffic. Note that DM-SETUP messages are not sent in the slot 2 of the DM slave link in order to enable the gateway to receive the TM downlink. Also it can be seen that the transmissions of the DM-SETUP messages in slot 4 of the DM slave link occur simultaneously with transmissions by the gateway on the TM uplink.

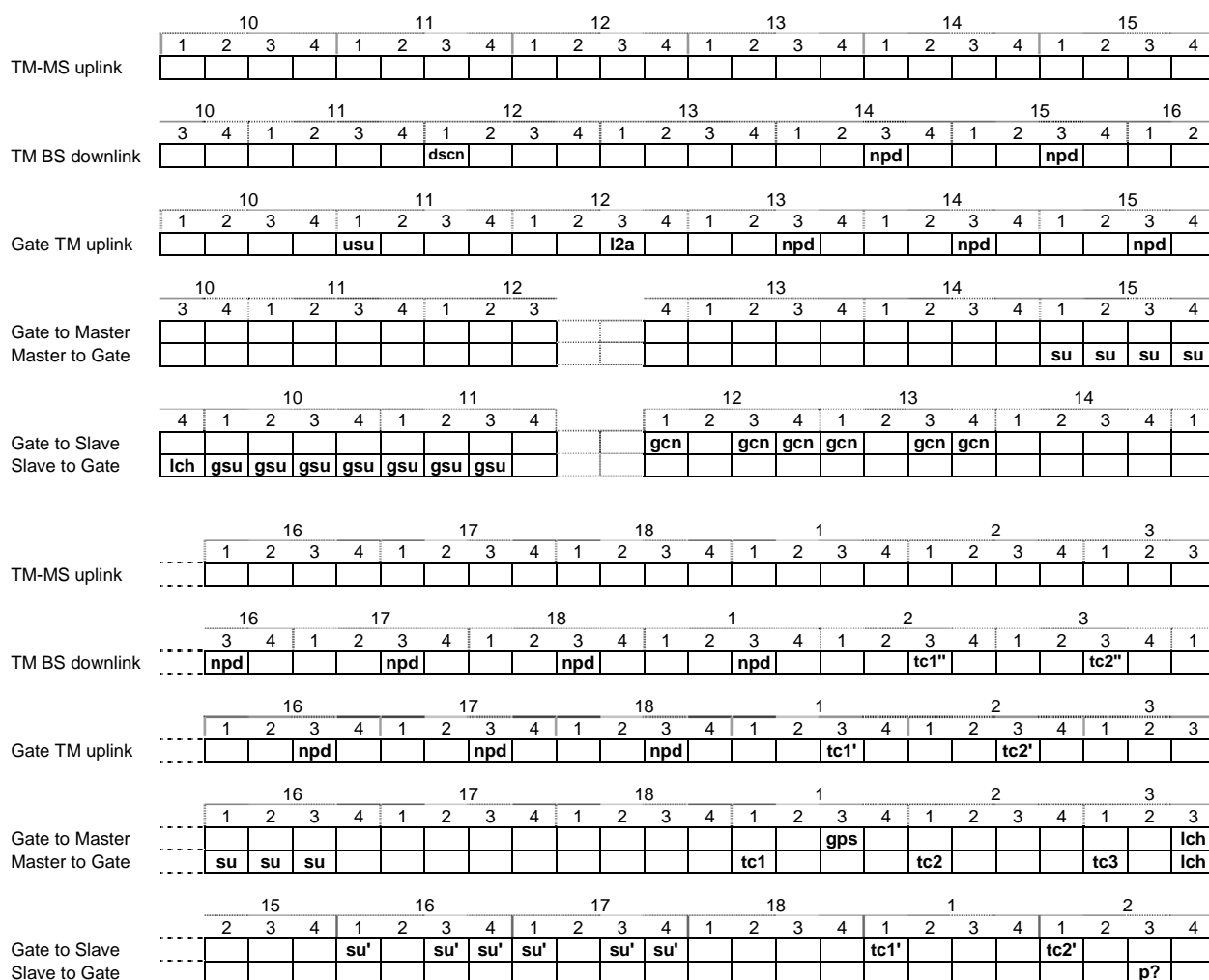

Figure 14: Timing diagram for group call from DM-MS via type 1A DM-REP/GATE

5 DM-MS layer 3 service description (for operation with a gateway)

5.1 Introduction

The following clauses describe the services that may be offered by layer 3 to the user application for operation with a gateway – either a DM-GATE or a DM-REP/GATE. The service description is described in terms of primitives and their parameters.

Layer 3 comprises a Direct Mode Call Control (DMCC) entity and, optionally, a Direct Mode Mobility Management (DMMM) entity. The definition of the DMCC-SAP and DMMM-SAP does not imply any specific implementation, but is rather used for the description of the protocol model. In the following clauses the word "shall" is used to describe the Service Access Points (SAPs) and the service primitives and parameters for traceability reasons in the protocol model, but they are not testable. The following description also does not imply any specific implementation.

NOTE: In an implementation, additional parameters may be included in the primitives in order to exchange additional information between the user application and layer 3.

5.2 Services offered at the DMCC-SAP

EN 300 396-3 [3], clause 5.2 shall apply.

5.3 Description of primitives at the DMCC-SAP

EN 300 396-3 [3], clause 5.3 shall apply with the following differences:

- i) Use of the DMCC-SDS DATA confirm primitive implies only that the short data message has been successfully sent as far as the gateway. It does not imply receipt by the called terminal.
- ii) The user application is not precluded from issuing a DMCC-SDS DATA request including a group address as the called party TSI. This form of short data message may be received by local DM-MSs in the group, but requests an acknowledgement only from the gateway.
- iii) The DMCC-SDS DATA and DMCC-SDS UNITDATA request primitives may include an "area selection" parameter.
- iv) The DMCC-SDS DATA and DMCC-SDS UNITDATA request primitives may include an "external subscriber number (called)" parameter, comprising up to 24 digits.
- v) The DMCC-SDS DATA and DMCC-SDS UNITDATA indication primitives may include an "external subscriber number (calling)" parameter, comprising up to 24 digits.
- vi) The DMCC-SETUP request primitive may include an "area selection" parameter.
- vii) The DMCC-SETUP request primitive may include an "external subscriber number (called)" parameter, comprising up to 24 digits.
- viii) The DMCC-SETUP indication primitive may include an "external source indicator" parameter indicating that a call from TMO was originated by an external subscriber.
- ix) The "presence check" parameter is not used in the DMCC-SETUP request primitive.
- x) The DMCC-TPNI indication primitive may include an "external subscriber number (calling)" parameter, comprising up to 24 digits.

NOTE 1: The DMCC-SETUP, DMCC-SDS DATA and DMCC-SDS UNITDATA primitives in EN 300 396-3 [3] contain a "communication type" parameter. This parameter enables the user application to specify, when within range of a DM-GATE or DM-REP/GATE, whether the gateway function is required for the call – thereby invoking operation according to the present document. If the gateway function is not required then the appropriate method of operation is invoked (i.e. operation according to EN 300 396-3 [3], EN 300 396-4 [4] or EN 300 396-7 [i.3]).

NOTE 2: The "called party TSI" in request primitives refers to the end destination, not to the gateway. Similarly, the "calling party TSI" in indication primitives refers to the call initiator, not to the gateway.

5.4 Description of parameters at the DMCC-SAP

EN 300 396-3 [3], clause 5.4 shall apply with the following differences:

- i) Parameter "cease cause" may have the following additional possible values:
 - interruption for TMO transaction in ongoing call;
 - TMO WAIT procedure;
 - TMO temporary break;
 - TMO slot numbering or slot timing change;
 - TMO call transaction timer expired.
- ii) Parameter "release cause" may have the following additional possible values:
 - call rejected by gateway (indication only);
 - call rejected by SwMI (indication only);
 - TMO call set-up failure (indication only);
 - pre-emptive use of resource by gateway (indication only);
 - TMO resource lost (indication only);
 - TMO call timer expired (indication only);
 - link to gateway not established or failed (indication only);
 - transmit authorization lost (indication only);
 - called party is under the same DM-GATE as the calling party (indication only);
 - called party busy (indication only);
 - unknown TETRA identity (indication only);
 - unknown external subscriber identity (indication only).
- iii) Parameter "SDS transfer result" may have the following additional possible values:
 - gateway rejected short data (acknowledged service only);
 - gateway does not support short data (acknowledged service only);
 - link to gateway not established or failed.
- iv) Parameter "report" may have the following additional possible value:
 - transmit authorization lost.

5.5 States for DMCC-SAP

EN 300 396-3 [3], clause 5.5 shall apply.

NOTE: For operation with a gateway, the DMCC-TX CEASED request and indication primitives when in state CALL ACTIVE Tx are always followed immediately by a DMCC-REPORT indication reporting a state change from CALL ACTIVE Tx to CALL ACTIVE Rx.

5.6 Services offered at the DMMM-SAP

The DMMM services are provided with a DMMM entity at the Service Access Point DMMM-SAP. The DMMM-SAP may provide the following services:

- registration: this service allows a user application to register with the gateway; the user application is then informed of the result of the registration;
- information to the user application concerning the presence of a gateway and its ability to provide a gateway service.

The flow of DMMM primitives is as given in figure 15.

NOTE: It is optional for a DM-MS to provide the DMMM services.

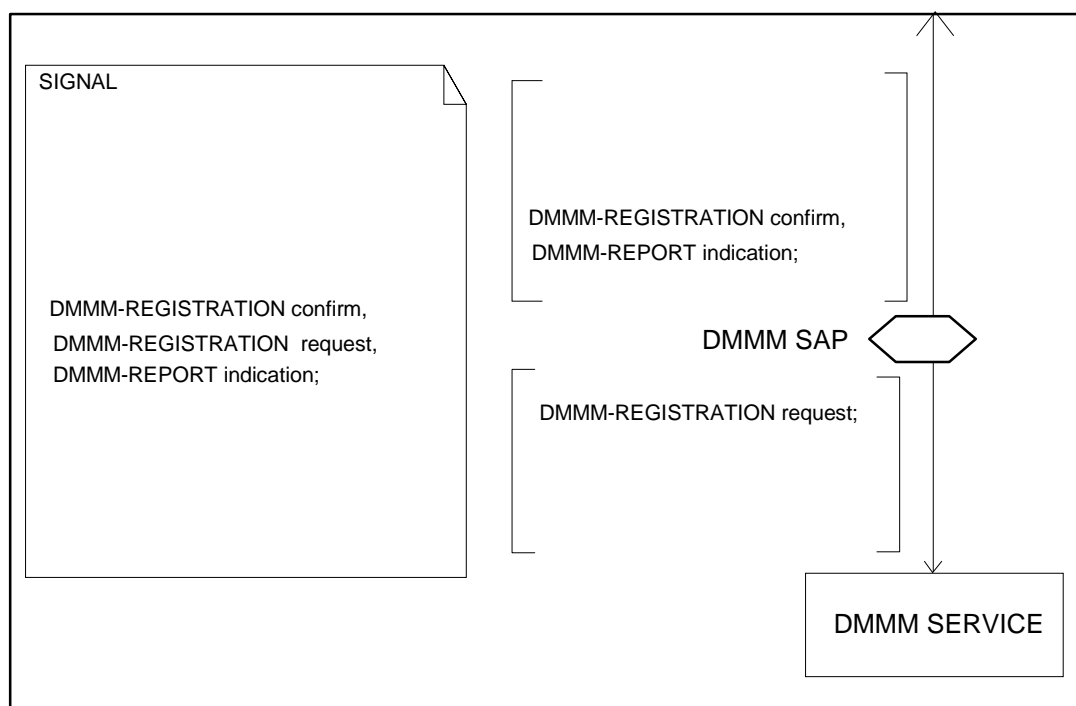

Figure 15: Services provided at DMMM-SAP

5.7 Description of primitives at the DMMM-SAP

The services shall be provided through primitives at the DMMM-SAP. This clause describes the primitives and their parameters.

The set of MM primitives that are available to provide the specified service to the user application are:

DMMM-REGISTRATION request/confirm;

DMMM-REPORT indication.

The information contained in the primitive description tables which follow corresponds to the following key:

- M: Mandatory;
- C: Conditional;
- O: Optional;
- : Not used.

5.7.1 DMMM-REGISTRATION primitive

DMMM-REGISTRATION request primitive shall be used by the user application to initiate registration of the DM-MS to the gateway.

DMMM-REGISTRATION confirm primitive shall be used to inform the user application that registration has been accepted and that service is available from the gateway.

The parameters shall be defined as follows.

Table 1: Parameters for the primitive DMMM-REGISTRATION

Parameter	Request	Confirm
Serviced identity (note)	O	O
NOTE: If included this is a group address that has been selected within the DM-MS.		

5.7.2 DMMM-REPORT primitive

DMMM-REPORT indication primitive shall be used as an indication to the user application that the registration request has failed, or been rejected by the gateway. It may also be used to indicate that the current registration is no longer valid.

Table 2: Parameters for the primitive DMMM-REPORT

Parameter	Indication
Registration status	M
Registration result	M

5.8 Description of parameters at the DMMM-SAP

Parameters shall be part of the primitives described in clause 5.7 and if applied the parameters shall contain the values specified in this clause.

- 1) **Serviced identity** =
 - GSSI.
- 2) **Registration result** =
 - registration label no longer valid;
 - ITSI not known to gateway;
 - no response from SwMI;
 - no response from gateway;
 - attachment rejected by SwMI;
 - request rejected by gateway;

- gateway cannot support requested group;
- undefined error;
- transmit authorization lost.

3) Registration status =

- not registered;
- registration rejected;
- registration status unchanged.

6 DM-MS layer 3 protocol (for operation with a gateway)

6.1 Introduction

The following clauses describe the layer 3 protocol for a DM-MS operating with a gateway – either a DM-GATE or a DM-REP/GATE.

The Direct Mode Call Control (DMCC) entity performs the DM-MS layer 3 functions for both circuit mode calls and short data messages (user-defined short messages and pre-coded status). The DMCC protocol when operating with a gateway is similar to the protocol defined in EN 300 396-3 [3], clause 6. The differences are detailed in clauses 6.2 and 6.3.

NOTE 1: The present document does not support gateway operation in which the gateway can support more than one call at a time on the DM RF carrier (or pair of duplex-spaced DM RF carriers for a type 1B DM-REP/GATE). Therefore references to frequency efficient mode in EN 300 396-3 [3], clause 6 do not apply to transactions via a gateway.

NOTE 2: For direct DM-MS to DM-MS operation the procedures in EN 300 396-3 [3] apply, even if a gateway is currently occupying the DM channel. Similarly for operation via a DM-REP the procedures in EN 300 396-4 [4] apply, even if a gateway is currently occupying the DM channel.

The Direct Mode Mobility Management (DMMM) entity is optional. If implemented, it performs the DM-MS layer 3 functions for registration when invoked by the user application. The procedures are defined in clause 6.4.

6.1.1 DMCC protocol states

EN 300 396-3 [3], clause 6.1.1 shall apply with the following differences:

- i) States CALL SETUP NORMAL ORIGINATING and CALL SETUP PRES_CHECK ORIGINATING are replaced by a single state CALL SETUP ORIGINATING.
- ii) State CALL ACTIVE TX RESERVATION is not appropriate for a DM-MS operating with a gateway.

6.1.2 DMMM protocol states

This clause defines the states that are used within the DMMM protocol description.

6.1.2.1 NOT-REGISTERED

This state exists when the DM-MS has neither been accepted nor rejected by the gateway. This state exists at initial start-up and after the validity of the registration label is no longer valid.

6.1.2.2 WAIT-REGISTRATION

This state exists when a DMMM originated registration transaction with the gateway is in progress.

6.1.2.3 REGISTRATION-ACCEPTED

This state exists when the gateway has accepted the DM-MS registration and the registration label is valid.

6.1.2.4 REGISTRATION-REJECTED

This state exists when the gateway has rejected the registration request from the DM-MS or subsequently cancels the registration.

6.2 Circuit mode calls

The DMCC protocol for circuit mode calls when operating with a gateway is similar to the protocol defined in EN 300 396-3 [3], clause 6.2 but with the following differences:

- i) Outgoing call set-up for a call through a gateway uses a two-phase process. The first phase is a message exchange with the gateway, initiated when the calling DM-MS sends the DM-GSETUP PDU; the DM-MS then awaits an interim acknowledgement (DM-GACK PDU) from the gateway, an acceptance (DM-GCONNECT PDU) indicating through connection, or a rejection (DM-RELEASE). During this phase the channel is in a form of reservation and the gateway is the master of the channel. The second phase of the call set-up takes place when the calling DM-MS receives DM-GCONNECT; then the DM-MS becomes master of the channel, sending the DM-SETUP PDU and starting traffic transmission.

This procedure applies on the DMO side for making both individual and group calls.

A group call may involve both DM users and TMO users. For a group call initiated by a DM-MS, the call does not proceed on the DMO side until transmission of the DM-SETUP PDU (i.e. after through connection on the TMO side).

NOTE 1: For a group call through a DM-GATE, the other DM-MSs in the call receive the DM-SETUP messages and traffic as transmitted by the master DM-MS. For a group call through a DM-REP/GATE, the other DM-MSs normally receive the DM-SETUP messages and traffic as re-transmitted by the DM-REP/GATE on the slave link, however a DM-MS may monitor the transaction directly from the transmitting DM-MS if it is unable to receive transmissions from the DM-REP/GATE.

- ii) A circuit mode call in progress may fail if the layer 2 in the calling DM-MS reports that the link to the gateway has been lost during the occupation period.
- iii) As in EN 300 396-3 [3], a DM-MS is master of the channel while it is transmitting circuit mode traffic (i.e. during the occupation period). However, at the end of the traffic transmission, the master role passes from the DM-MS to the gateway for the subsequent reservation period.
- iv) New messages are used for the changeover procedure. This is because the requesting DM-MS sends information about the required service in its changeover request (DM-GTX REQUEST) so that the gateway can forward the transmit request to the SwMI. The gateway does not send the final acknowledgement (DM-GTX ACCEPT) to the requesting DM-MS until it has received the transmit permission from the SwMI. The DM-MS then sends the DM-SETUP PDU as in EN 300 396-3 [3] part.
- v) New messages (DM-GPREEMPT, DM-GPRE ACCEPT) are used for a pre-emption within the ongoing call if the gateway is currently the master of the channel. This is because the requesting DM-MS needs to send information about the required service, to be forwarded to the SwMI.

The DM-PREEMPT PDU is used for a pre-emption within the ongoing call if a DM-MS is currently the master of the channel. This is needed in order to stop the current traffic transmission. Following receipt of a DM-PRE ACCEPT PDU, the requesting DM-MS then sends a DM-GTX REQUEST to the gateway for forwarding to the SwMI.

NOTE 2: As in EN 300 396-3 [3], the DM-PREEMPT PDU is used for pre-emption for a new call.

The differences are detailed in the following clauses.

6.2.1 Procedures for outgoing call set-up through a gateway

6.2.1.1 Outgoing call set-up

A user application initiates call establishment or continuation of an ongoing call by transferring a DMCC-SETUP request primitive across the DMCC-SAP to the DMCC entity. The following procedure applies if the DMCC-SETUP request indicates that gateway operation is required. In the case of protected circuit mode data, the DMCC-SETUP request includes parameters indicating both the target interleaving depth and the lowest acceptable interleaving depth; this allows the calling DMCC to accept a lower interleaving depth than that requested. The DMCC-SETUP request also indicates the priority of the call.

The DMCC shall then use the appropriate procedure as follows:

- If use of the gateway is restricted due to URT, see clause 6.6.1, then the DMCC shall issue a DMCC-RELEASE indication to the user application with "transmit authorization lost".
- Otherwise, if the request relates to continuation of an ongoing call then the DMCC shall use the procedures in clause 6.2.4 or 6.2.5 to decide how to proceed.
- Otherwise (i.e. if the request relates to a new call):
 - if the DM channel is currently busy i.e. occupied, reserved or in a registration phase, then the DMCC shall use the procedures in clause 6.2.6 to decide whether pre-emption is valid;
 - if the DM channel is currently free, the DMCC shall immediately perform the following call set-up procedure;
 - if the DM channel is in state unknown, the DMCC shall either immediately perform the following call set-up procedure or issue a DMCC-RELEASE indication to the user application.

NOTE 1: The channel may be in state unknown either because the DM-MS has not been performing the fast call set-up surveillance procedures (see clause 8.4.2.2.2) or because the DM-MS temporarily does not know the state of the channel. In the former case, when the user wishes to make a call, the DMCC should perform the following call set-up procedure, sending a DM-SETUP PDU – so that layer 2 will perform the procedure for initial determination of the DM channel state and send the message if the surveillance indicates that the DM channel is free (see clause 8.4.2.2.3). In the latter case it is an MS designer choice whether the DMCC performs the following call set-up procedure or issues a DMCC-RELEASE indication to the user application.

The DMCC shall convert the DMCC-SETUP request into a corresponding DM-GSETUP PDU and send it, and shall enter state CALL SETUP ORIGINATING; the value of the "request label" element in the DM-GSETUP PDU shall be set equal to the last used value + 1. After sending the DM-GSETUP PDU, the DMCC shall await a DMA-REPORT indication from layer 2, reporting on the progress of the transmission.

If the DMCC receives a DMA-REPORT indication reporting failure to transmit the DM-GSETUP PDU because the channel has become busy (or the channel state remains unknown) then it shall either:

- a) inform the user application with a DMCC-RELEASE indication and return to state IDLE; or
- b) for a sufficiently high priority request, if the channel has become busy, invoke the pre-emption procedure (see clauses 6.2.6 or 6.2.4).

Otherwise, if the DMCC receives a DMA-REPORT indication reporting that the DM-GSETUP PDU has been transmitted the appropriate number of times, the DMCC shall start timer DT301 and shall await a response from the gateway:

- If the DMCC receives a DM-GACK PDU indicating that the message was not fully received then it shall send the DM-GSETUP message again (indicating "immediate retransmission" in the DMA-UNITDATA request), start timer DT301 again using the initial value and await a response from the gateway.
- If the DMCC receives a DM-GACK PDU indicating that the message has been fully received then it shall stop timer DT301, start timer DT302 using the specified value and await a further response from the gateway.

- If the DMCC receives a further DM-GACK indicating that the message has been fully received then it shall start timer DT302 again using the specified value and continue to await a further response from the gateway.
- If the DMCC receives a DM-GCONNECT PDU containing "request label" element equal to the value used in the DM-GSETUP PDU, and either accepting the requested service or, if applicable, offering an acceptable reduced service (e.g. interleaving depth, gateway encryption state on SwMI), then it shall:
 - stop timer DT301 or DT302 as appropriate;
 - send the DM-SETUP PDU as master DM-MS, including the basic service information from the DM-GCONNECT PDU, i.e. accepting the reduced service if applicable;
 - enter state CALL ACTIVE TX OCCUPATION (following the procedures for a master DM-MS during occupation);
 - inform the user application with a DMCC-SETUP confirm;
 - issue a DMC-CONFIGURE request for lower layer traffic configuration; and
 - start timer DT311.
- If the DMCC receives a DM-GCONNECT PDU containing "request label" element equal to the value used in the DM-GSETUP PDU but offering a reduced service that is not acceptable then it shall stop timer DT301 or DT302, send the DM-RELEASE PDU as master DM-MS, issue a DMCC-RELEASE indication to the user application and return to state IDLE.
- If the DMCC receives a DM-GCONNECT PDU containing "request label" element not equal to the value used in the DM-GSETUP PDU then it shall stop timer DT301 or DT302 and shall send the DM-RELEASE PDU as master DM-MS. It shall then either send the DM-GSETUP PDU again (as a slave DM-MS and without incrementing the "request label" element) or otherwise issue a DMCC-RELEASE indication to the user application and return to state IDLE. If sending the DM-GSETUP PDU again, the DMCC may indicate "immediate retransmission" in the DMA-UNITDATA request.
- If the DMCC receives a DM-RELEASE PDU from the gateway then it shall stop timer DT301 or DT302, issue a DMCC-RELEASE indication to the user application and return to state IDLE.
- If the DMCC receives a DM-SETUP or DM-SETUP PRES PDU from the gateway then it shall stop timer DT301 or DT302, issue a DMCC-RELEASE indication to the user application and obey the appropriate procedures for an incoming call set-up, as defined in clauses 6.2.2.1 or 6.2.2.2.
- If layer 2 reports that the channel has been lost (e.g. the gateway has accepted a pre-emption request from another DM-MS or has sent set-up signalling for another call) then the DMCC shall stop timer DT301 or DT302, issue a DMCC-RELEASE indication to the user application and return to state IDLE.
- If timer DT301 expires then the DMCC shall either send the DM-GSETUP PDU again (without incrementing the "request label" element and not indicating "immediate retransmission" in the DMA-UNITDATA request), or otherwise issue a DMCC-RELEASE indication to the user application, issue a DMC-CONFIGURE request to layer 2 indicating "call release" and return to state IDLE. The DMCC shall attempt the call set-up for up to a maximum of DN301 times if the set-up has not succeeded or failed on other criteria in this list.
- If timer DT302 expires then the DMCC shall either send the DM-GSETUP PDU again (without incrementing the "request label" element and not indicating "immediate retransmission" in the DMA-UNITDATA request), or otherwise issue a DMCC-RELEASE indication to the user application, issue a DMC-CONFIGURE request to layer 2 indicating "call release" and return to state IDLE. The DMCC shall attempt the call set-up for up to a maximum of DN302 times if the set-up has not succeeded or failed on other criteria in this list.
- If use of the gateway becomes restricted (due to validity time expiring or receipt of a presence signal with validity time = 0, see clause 6.6.1), then the DMCC shall remain in the same state but abandon the call set-up at the next opportunity (i.e. DT301 or DT302 expiry, or receipt of DM-GCONNECT or DM-RELEASE PDU) by taking the call release path in the corresponding procedure. The release cause reported in the DMCC-RELEASE indication to the user application at that time should be "transmit authorization lost".

If the user application issues a DMCC-RELEASE request primitive while timer DT301 or DT302 is running then the DMCC shall stop that timer, issue a DMC-CONFIGURE request to layer 2 indicating "call release" and return to state IDLE.

NOTE 2: In the above case, the calling DM-MS leaves the call set-up without signalling. It is recommended that this procedure is not used other than for emergency reasons.

NOTE 3: The "request label" element in the DM-GSETUP PDU is incremented for each new call set-up that the DM-MS makes through the gateway. It is included in DM-GSETUP and DM-GCONNECT PDUs to guard against any possibility that signalling messages for an old call set-up could be confused with signalling messages for a new call set-up. (Without this element, ambiguity is nominally possible if the DM-MS perceives an old call set-up as having failed because of propagation problems and attempts to make a new call while the gateway is actually continuing to process the old call).

NOTE 4: The behaviour of the user application on receipt of DMCC-RELEASE indication is outside the scope of the present document. In some circumstances, if the release cause does not indicate that the DM channel is busy and the user application knows that fewer than DN301 or DN302 attempts have been made, then it may be desirable to communicate with other in range DM-MS by retrying the call set up as a direct MS-MS call in accordance with EN 200 396-3 [3]. A DMCC-RELEASE indication with release cause "link to gateway not established or failed" may be used to indicate that the DM-MS is not (or no longer) in range of the gateway.

6.2.1.2 Temporary group address

EN 300 396-3 [3], clause 6.2.1.3 shall apply.

6.2.1.3 Layer 3 addressing in DM-GSETUP PDU

6.2.1.3.1 Called party address

The DMCC shall provide the called party SSI as a layer 3 element within the DM-GSETUP PDU. Also, for an inter-MNI call or if the DM-MS does not wish to use its true ISSI as the layer 2 source address, it shall provide the called MNI.

6.2.1.3.2 Area selection

The DMCC shall include an "area selection" element as a layer 3 element within the DM-GSETUP PDU. This element may be set to 0000₂ to indicate "area not defined".

6.2.1.3.3 Calls to external subscribers

A DM-MS may make a call through a DM gateway to a subscriber in an external network (i.e. beyond the TMO system). The DM-GSETUP PDU shall address the external network gateway using a particular SSI or TSI as the called party address and shall contain the external network subscriber number. The call set-up procedure shall then be as defined in clause 6.2.1.1.

NOTE: The particular address or addresses which identify the external network gateway or gateways are not defined by the present document.

6.2.1.3.4 Calling party address

If the DM-MS does not wish to use its true ISSI as the layer 2 source address (i.e. if it is using pseudo addressing at layer 2) then the DMCC shall provide its ITSI as the "calling party TSI" element within the layer 3 PDU.

6.2.2 Procedures for incoming call set-up

6.2.2.1 Incoming call set-up without presence check

EN 300 396-3 [3], clause 6.2.1.2 shall apply.

NOTE 1: The DM-SETUP PDU may have been generated by the gateway i.e. for a call transaction originated in the TMO system (or in an external network). Or, for a group call, the PDU may have been originated by a DM-MS making a call that involves both DM and TMO users.

NOTE 2: A DM-MS is permitted to receive an incoming via DM-GATE transaction to either its individual address or one of its group addresses even if its use of the gateway is restricted or it has not received a presence signal from the gateway, see 6.6.1, or it has received a presence signal from a repeater or another gateway.

6.2.2.2 Incoming call set-up with presence check

EN 300 396-3 [3], clause 6.2.2.2 shall apply, with the following additions to the procedures for the called DMCC while timer DT307 is running:

NOTE 1: The DM-SETUP PRES PDU will have been generated by the gateway i.e. for a call transaction originated in the TMO system (or in an external network). The called DM-MS then sends the DM-CONNECT or DM-DISCONNECT PDU addressed to the gateway. After sending DM-CONNECT, the called DM-MS then expects to receive a response (e.g. DM-CONNECT ACK or DM-RELEASE) from the gateway.

- If the DMCC receives a DM-OCCUPIED PDU for the call then it shall issue a DMCC-COMPLETE indication to the user application, enter state CALL ACTIVE RX OCCUPATION (following the procedures for a slave DM-MS during occupation), stop timer DT307 and issue a DMC-CONFIGURE request for lower layer traffic configuration.
- If the DMCC receives a different DM-SETUP PRES PDU or a DM-SETUP PDU from the gateway then it shall stop timer DT307, issue a DMCC-RELEASE indication to the user application and obey the appropriate procedure for an incoming call set-up.
- If layer 2 reports (using a DMC-REPORT indication) that the gateway has accepted a pre-emption request from another DM-MS then the DMCC shall issue a DMCC-RELEASE indication to the user application, stop timer DT307 and return to state IDLE.
- If the user application wishes to abandon the incoming call set-up then it shall transfer a DMCC-RELEASE request to the DMCC. The DMCC shall issue a DMC-CONFIGURE request to layer 2 indicating "call release" and shall return to state IDLE.

NOTE 2: In the above case the called DM-MS leaves the call set-up without signalling. It is recommended that this procedure is not used other than for emergency reasons.

6.2.2.3 Transmitting Party Number Identification (TPNI) during incoming call set-up

If the layer 2 source address used for sending the call set-up message was a true SSI then the called DMCC(s) shall use the addressing information provided in the DMA-UNITDATA indication to provide TPNI to the user application as the "calling party TSI" parameter in the DMCC-SETUP indication primitive. The called DMCC(s) may also indicate whether the set-up was originated by a DM-MS or generated by the gateway.

If element "external source flag" in the call set-up message is set to 1 then the called DMCC(s) may indicate to the user application that the call originated in an external network.

6.2.3 Usage of DM-OCCUPIED PDU

6.2.3.1 Sending of DM-OCCUPIED PDU by master DM-MS

EN 300 396-3 [3], clause 6.2.3.1 shall apply.

6.2.3.2 Late entry by slave DM-MS

EN 300 396-3 [3], clause 6.2.3.2 shall apply.

6.2.4 Procedures during occupation

6.2.4.1 Master DM-MS

A master DM-MS sending circuit mode traffic shall obey the procedures in EN 300 396-3 [3], clause 6.2.4.1 with the following differences:

- i) In procedure a), the master DM-MS shall accept a DM-PREEMPT PDU generated by the gateway, irrespective of the priority.

NOTE 1: For example, pre-emption by the gateway may occur within the ongoing call if the gateway has received a D-TX INTERRUPT or a D-TX WAIT PDU from the SwMI withdrawing transmit permission, or if there is a TMO break, or if there has been a slot numbering or slot timing change on the TMO side, or if the TMO call transaction timer has expired. Or a new call pre-emption may occur if the gateway wishes to support a different TMO call. See clause 14.6, difference iii).

- ii) In procedures b) and d), after sending the DM-TX CEASED PDU indicating the required reservation time, the DMCC shall issue a DMCC-REPORT indication to the user application and shall enter state CALL ACTIVE RX RESERVATION following the procedures for a slave DM-MS during reservation (as defined in clause 6.2.5.2).

A master DM-MS sending circuit mode traffic shall obey EN 300 396-3 [3], clause 6.2.4.1 bullet a) to d) and shall also obey the following procedures:

- e) If the DMCC receives a DM-GRELEASE PDU from the gateway, it shall send a DM-RELEASE PDU indicating "TMO resource lost or call timer expired" or "cause not defined or unknown" as appropriate, stop timer DT311, inform the user application with a DMCC-RELEASE indication and return to state IDLE.

NOTE 2: After receipt of DM-GRELEASE, the DMCC terminates the ongoing call and returns to state IDLE. The user application may then choose to request a new call (issuing the appropriate DMCC-SETUP request primitive). For example, for a group call interrupted by loss of the TMO resource, the user application may choose to request a local call to the same group address; in this case the DMCC follows the appropriate procedure (e.g. in EN 300 396-3 [3] or EN 300 396-4 [4]) for outgoing new call set-up.

- f) If layer 2 reports that the channel is now in reservation for the call (DMC-REPORT indication) then the DMCC shall send a DM-TX CEASED PDU, stop timer DT311, inform the user application with a DMCC-TX CEASED and DMCC-REPORT indication, and enter state CALL ACTIVE RX RESERVATION following the procedures for a slave DM-MS during reservation (as defined in clause 6.2.5.2).
- g) If layer 2 reports that the link to the gateway has failed (DMC-REPORT indication) then the DMCC shall send a DM-RELEASE PDU, stop timer DT311, inform the user application with a DMCC-RELEASE indication and return to state IDLE.
- h) If use of the gateway becomes restricted (due to validity time expiring or receipt of a presence signal with validity time = 0, see clause 6.6.1), then, unless already sending a DM-RELEASE PDU, a DM-PRE ACCEPT PDU or a DM-TX CEASED PDU, the DMCC shall send a DM-RELEASE PDU indicating "transmit authorization lost", stop timer DT311, inform the user application with a DMCC-RELEASE indication and return to state IDLE.

6.2.4.2 Slave DM-MS

A slave DM-MS receiving circuit mode traffic shall obey the procedures in EN 300 396-3 [3], clause 6.2.4.2 except that a slave DM-MS that is only able to monitor the master DM-MS directly in a call through a DM-REP/GATE shall not attempt to pre-empt the master DM-MS and the pre-emption procedure h) shall be replaced by the following procedure:

- h) If the user application issues a DMCC-SETUP request for continuation of the ongoing call then the DMCC shall check whether pre-emption is valid i.e. whether the request priority is pre-emptive or emergency pre-emptive and is higher than the priority of the current transmission:

- 1) If pre-emption is valid and the gateway is currently master of the DM channel then the DMCC may send a DM-GPREEMPT PDU addressed to the gateway. If the DM-MS does not wish to use its true ISSI as the layer 2 source address then the DMCC shall provide its ITSI as the "calling party TSI" element within the layer 3 PDU. The DMCC shall enter state WAIT RSP OCCUPATION and shall then wait for a response from the gateway:
- If the DMCC receives a DM-GACK PDU then it shall start timer DT308 using the specified value and shall await a further response from the gateway.
 - If the DMCC receives a further DM-GACK then it shall start timer DT308 again using the specified value and shall continue to await a further response from the gateway.
 - If the DMCC receives a DM-GPRE ACCEPT PDU then it shall send the DM-SETUP PDU as master DM-MS, enter state CALL ACTIVE TX OCCUPATION (following the procedures for a master DM-MS during occupation), inform the user application with a DMCC-SETUP confirm, issue a DMC-CONFIGURE request for lower layer traffic configuration, stop timer DT308 (if running) and start timer DT311.
 - If the DMCC receives a DM-GREJECT PDU then it shall inform the user application with a DMCC-REPORT indication, stop timer DT308 (if running) and return to the state appropriate to the ongoing call.
 - If it receives a DMA-REPORT or DMC-REPORT indication reporting a change of master, and if the pre-emption is still valid, then the DMCC may attempt a pre-emption addressed to the new master. Or, if it receives a DMA-REPORT or DMC-REPORT indicating that the channel is now free (or in unknown state) or that the call has been lost then the DMCC may obey the procedures for outgoing call set-up, as defined in clause 6.2.1.1. For other DMA-REPORTs indicating random access failure, the DMCC shall inform the user application of the failure with a DMCC-REPORT indication and shall return to the state appropriate to the ongoing call.
 - If use of the gateway becomes restricted (due to validity time expiring or receipt of a presence signal with validity time = 0, see clause 6.6.1), then: if there has been no response from layer 2, the DMCC shall indicate to layer 2 that no further random access transmissions are permitted for the outstanding request; the DMCC shall remain in the same state itself but abandon the pre-emption at the next opportunity (i.e. DT308 expiry, or receipt of DM-GPRE ACCEPT or DM-GREJECT PDU, or receipt of DMA-REPORT or DMC-REPORT indication). The reason reported in the DMCC-REPORT indication to the user application at that time should be "transmit authorization lost". In the case of receiving DM-GPRE ACCEPT the DMCC shall inform the user application with a DMCC-REPORT indication, stop timer DT308 (if running) and return to state CALL ACTIVE RX RESERVATION.
 - If timer DT308 expires then the DMCC shall inform the user application of the failure with a DMCC-REPORT indication and shall return to the state appropriate to the ongoing call.

Otherwise, if pre-emption is valid and a DM-MS is currently master of the DM channel then the DMCC may send a DM-PREEMPT PDU addressed to the master DM-MS and shall enter state WAIT RSP OCCUPATION. It shall then wait for a response from the master DM-MS:

- If the DMCC receives a DM-PRE ACCEPT PDU from the master DM-MS, it shall then send a DM-GTX REQUEST addressed to the gateway (indicating "DM-GTX REQUEST after pre-emption" in the DMA-UNITDATA request). It shall then enter state WAIT RSP RESERVATION and shall wait for a response from the gateway, obeying procedure a) of clause 6.2.5.2.
- If the DMCC receives a DM-REJECT PDU from the master DM-MS, it shall inform the user application with a DMCC-REPORT indication and shall return to the state appropriate to the ongoing call.

- If it receives a DMA-REPORT indication reporting a change of master, and if the pre-emption is still valid, then the DMCC may attempt a pre-emption addressed to the new master. Or, if it receives a DMA-REPORT indicating that the channel is now free (or in unknown state) then the DMCC may obey the procedures for outgoing call set-up, as defined in clause 6.2.1.1. For other DMA-REPORTs indicating random access failure, the DMCC shall inform the user application of the failure with a DMCC-REPORT indication and shall return to the state appropriate to the ongoing call.
 - If use of the gateway becomes restricted (due to validity time expiring or receipt of a presence signal with validity time = 0, see clause 6.6.1), then: if there has been no response from layer 2, the DMCC shall indicate to layer 2 that no further random access transmissions are permitted for the outstanding request; the DMCC shall remain in the same state itself but abandon the pre-emption at the next opportunity (i.e. receipt of DM-PRE ACCEPT or DM-REJECT PDU, or receipt of DMA-REPORT indication). Where applicable the reason reported in the DMCC-REPORT indication to the user application at that time should be "transmit authorization lost". In the case of receiving DM-PRE ACCEPT the DMCC shall inform the user application with a DMCC-REPORT indication and return to state CALL ACTIVE RX RESERVATION.
- 2) If pre-emption is not valid then the DMCC may either discard the request (informing the user application with a DMCC-REPORT indication) or may hold the request until the end of the current transmission and then send a changeover request, as defined in clause 6.2.5.2, and indicating that the changeover request has been held during occupation when it issues the DMA-UNITDATA request. If the "recent user flag" is set to value 1 then the DMCC shall also indicate in the primitive that this is a recent user changeover request.

6.2.4.3 Transmitting Party Number Identification (TPNI) during occupation

6.2.4.3.1 Master DM-MS

For an inter-MNI group call or for an intra-MNI group call if a master DM-MS did not use its true ISSI as the layer 2 source address when sending the DM-SETUP message, and if local DM TPNI is required, then during occupation the master DMCC shall send the DM-INFO PDU containing its ITSI.

NOTE: In this case, the master DMCC may choose to send the DM-INFO PDU intermittently throughout the occupation period. This is strongly recommended for group calls, in order to provide TPNI information to DM late entrants. The gateway does not forward the information in DM-INFO to the TMO side; TMO TPI uses information from the start of transaction signalling.

6.2.4.3.2 Slave DM-MS

If a slave DM-MS receiving circuit mode traffic receives a DM-INFO PDU containing TPNI information, and if the information has not been received already, then the DMCC shall deliver the information to the user application in a DMCC-TPNI indication primitive. The TPNI information may be the calling party TSI, or it may be an external subscriber number if the gateway is currently master of the channel.

6.2.5 Procedures during reservation

6.2.5.1 Master DM-MS

For operation with a gateway, the gateway is always master of the channel during the reservation period. Therefore the DM-MS procedures in EN 300 396-3 [3], clause 6.2.5.1 do not apply.

6.2.5.2 Slave DM-MS

During the reservation period, a DM-MS in the ongoing call shall obey the procedures in EN 300 396-3 [3], clause 6.2.5.2 except that the changeover procedure a) shall be replaced by the following procedure:

- a) If the user application issues a DMCC-SETUP request primitive requesting to transmit in the ongoing call then the DMCC shall send a DM-GTX REQUEST PDU addressed to the gateway. If the DM-MS does not wish to use its true ISSI as the layer 2 source address then the DMCC shall provide its ITSI as the "calling party TSI" element within the layer 3 PDU. The DMCC shall enter state WAIT RSP RESERVATION and shall then wait for a response from the gateway:
- If it receives a DM-GACK PDU then it shall start timer DT309 using the specified value and shall await a further response from the gateway.
 - If the DMCC receives a further DM-GACK then it shall start timer DT309 again using the specified value and shall continue to await a further response from the gateway.
 - If it receives a DM-GTX ACCEPT PDU then it shall send the DM-SETUP PDU as master DM-MS, enter state CALL ACTIVE TX OCCUPATION (following the procedures for a master DM-MS during occupation), inform the user application with a DMCC-SETUP confirm, issue a DMC-CONFIGURE request for lower layer traffic configuration, stop timer DT309 (if running) and start timer DT311.
 - If it receives a DM-GREJECT PDU then it shall inform the user application with a DMCC-REPORT indication, stop timer DT309 (if running) and return to state CALL ACTIVE RX RESERVATION.
 - If it receives a DMA-REPORT or DMC-REPORT indication reporting that the channel is now free (or in unknown state) then the DMCC may obey the appropriate procedures for outgoing call set-up, as defined in clause 6.2.1.1. For other DMA-REPORTs indicating random access failure, the DMCC shall inform the user application of the failure with a DMCC-REPORT indication and shall return to state CALL ACTIVE RX RESERVATION.
 - If use of the gateway becomes restricted (due to validity time expiring or receipt of a presence signal with validity time = 0, see clause 6.6.1), then: if there has been no response from layer 2, the DMCC shall indicate to layer 2 that no further random access transmissions are permitted for the outstanding request; the DMCC shall remain in the same state itself but abandon the changeover at the next opportunity (i.e. DT309 expiry or receipt of DM-GTX ACCEPT or DM-GREJECT PDU, or receipt of DMA-REPORT or DMC-REPORT indication). Where applicable the reason reported in the DMCC-REPORT indication to the user application at that time should be "transmit authorization lost". In the case of receiving DM-GTX ACCEPT the DMCC shall inform the user application with a DMCC-REPORT indication, stop timer DT309 (if running) and return to state CALL ACTIVE RX RESERVATION.
 - If timer DT309 expires then the DMCC shall inform the user application of the failure with a DMCC-REPORT indication and shall return to state CALL ACTIVE RX RESERVATION.

If, while waiting for a response, condition b), c1), d), e1), f) or h) applies then the DMCC shall abandon its request procedure (reporting the failure to the user application) and shall obey that other procedure. It shall also obey procedures g) and j) unless it chooses to attempt outgoing call set-up on the free channel.

NOTE: Procedure a) applies if the user application issues a DMCC-SETUP request primitive requesting to transmit in the ongoing call. If the user application issues a DMCC-SETUP request primitive relating to a new call, the DMCC should behave as if the user application had issued a DMCC-RELEASE request primitive before issuing the DMCC-SETUP request primitive.

6.2.5.3 Pre-emption of short data sent as a transaction within a circuit mode call

If the user application issues a DMCC-SETUP request for continuation of an ongoing circuit mode call during a short data transaction being sent as a transaction within that call then the DMCC shall check whether pre-emption is valid i.e. whether the request priority is pre-emptive or emergency pre-emptive and is higher than the priority of the short data transmission:

- A slave DM-MS that is only able to monitor the master DM-MS directly in a call through a DM-REP/GATE shall not attempt to pre-empt the master DM-MS.

- If pre-emption is valid then the DMCC may attempt pre-emption. It shall use the procedure defined in clause 6.2.4.2 h).
- Otherwise the DMCC may either discard the request (informing the user application with a DMCC-REPORT indication) or may hold the request until the end of the short data transmission and then send a changeover request, as defined in clause 6.2.5.2 a).

6.2.6 Procedures to set up a new call by pre-emption

EN 300 396-3 [3], clause 6.2.6 shall apply. A DM-MS that is only able to monitor the master DM-MS directly in a call through a DM-REP/GATE may attempt to pre-empt the master DM-MS for a new call.

The DMCC may also use the new call pre-emption procedure to pre-empt the gateway during a registration phase.

NOTE 1: When pre-empting for a new call establishment, the DM-MS uses the DM-PREEMPT PDU addressed to the master of the channel. The master may be either the gateway or a DM-MS during occupation. However, it is always the gateway for the reservation period during call set-up through a gateway and for the reservation period after a call transaction; and it is always the gateway during a registration phase.

NOTE 2: After receiving a DM-PRE ACCEPT PDU, the pre-empting DM-MS obeys the appropriate procedure for outgoing call set-up, as defined in the appropriate part of EN 300 396, according to the required communication type for the new call.

6.3 Short Data Service (SDS) procedures

The DMCC protocol for the Short Data Service (SDS) when operating with a gateway is similar to the protocol defined in EN 300 396-3 [3], clause 6.3. The primitives and PDUs used are the same, apart from some additional parameters / elements. Also, short data messages may be sent in any of the same four modes (i.e. as a stand-alone transaction on a free channel, as a stand-alone transaction after pre-emption, by a transmitting DM-MS stealing from its circuit mode traffic or as a transaction within an ongoing circuit mode call).

Because of the multi-link nature of operation when sending short data through a gateway, there are some differences in the types of service offered. Short data messages are acknowledged only at layer 2 on the TMO system. For consistency, when a DM-MS sends a short data message through a gateway using the acknowledged service, the DM-SDS ACK PDU is generated only by the gateway – as the equivalent of a TMO layer 2 (LLC) acknowledgement. Therefore, when the DMCC issues a DMCC-SDS DATA confirm primitive to the user application, this implies only that the short data message has been successfully transferred across the DM air interface as far as the gateway; it does not imply receipt by the called terminal on the TMO system.

When initiating a group-addressed short data message transfer through a gateway, the user application may request either the unacknowledged or acknowledged service:

- 1) For an unacknowledged transfer, the DMCC instructs layer 2 to send the DM-SDS UDATA PDU several times – up to a maximum of DN314 times. The DM-MS does not receive an explicit acknowledgement that the message has been received by the gateway (though, for operation through a DM-REP/GATE, the DM-MS may be able to use the re-transmission on the slave link to infer that the layer 2 in the gateway has received the message). Any local DM-MSs in the group that receive the short data message will pass it to the user application.
- 2) For an acknowledged transfer, the DMCC uses the DM-SDS DATA PDU addressed to the group. This requests an acknowledgement from the gateway. Any local DM-MSs in the group may receive the short data message and pass it to the user application, but they do not respond (see clause 8.5.4.2). The DMCC may send the DM-SDS DATA PDU again if it does not receive a response from the gateway.

In either case, for a group-addressed short data message sent through a DM-GATE, local DM-MSs in the group receive the message as transmitted by the master DM-MS. For a group-addressed short data message sent through a DM-REP/GATE, local DM-MSs in the group normally receive the message as re-transmitted by the DM-REP/GATE on the slave link, however a DM-MS may receive the message directly from the transmitting DM-MS if it is unable to receive transmissions from the DM-REP/GATE.

When initiating a short data message transfer through a gateway, and if the short data is addressed to an individual called party, the user application may request either the acknowledged or unacknowledged service. Use of the acknowledged service will generally provide more efficient operation.

When a DM-MS sends a short data message on a free channel, the first message transmitted is the DM-SDS UDATA or DM-SDS DATA PDU. The DM-MS transmits this message as master of the channel as in EN 300 396-3 [3]. Unlike the protocol for circuit mode calls there is no initial message exchange with the gateway. This is because the whole short data message is transferred to the gateway (and acknowledged if appropriate) before the gateway starts to send the message onwards to the SwMI.

When the gateway transmits a short data message that originated in the TMO system, it may use either the acknowledged or unacknowledged service on the DMO side if the short data is addressed to an individual DM-MS. It uses the unacknowledged service on the DMO side if the short data is addressed to a group.

6.3.1 Sending short data

6.3.1.1 Sending short data on a free channel

6.3.1.1.1 Sending unacknowledged short data on a free channel

EN 300 396-3 [3], clause 6.3.1.1.1 shall apply except that a DM-MS shall not initiate a transfer if use of the gateway is restricted due to URT, see clause 6.6.1 and, if a DM-MS operating through a DM-REP/GATE monitors the slave link to deduce the success or failure of the link establishment to the gateway, then the DMCC may use parameter "link to gateway not established or failed" in the DMCC-SDS REPORT indication to inform the user application that the short data transfer may have failed.

6.3.1.1.2 Sending acknowledged short data on a free channel

EN 300 396-3 [3], clause 6.3.1.1.2 shall apply except that:

- i) a DM-MS shall not initiate the transfer if use of the gateway is restricted due to URT, see clause 6.6.1;
- ii) after sending a DM-SDS DATA PDU, the DMCC awaits a response (DM-SDS ACK or DM-REJECT) from the gateway – not from the called DM-MS;
- iii) if the DMCC receives a DM-REJECT PDU then it shall use parameter "gateway rejected short data" or "gateway does not support short data" in the DMCC-SDS REPORT indication.

6.3.1.2 Sending short data by pre-emption

EN 300 396-3 [3], clause 6.3.1.2 shall apply except that a DM-MS shall not initiate the transfer if use of the gateway is restricted due to URT, see clause 6.6.1. An idle DM-MS that is only able to monitor the master DM-MS directly in a transaction through a DM-REP/GATE may attempt to pre-empt the master DM-MS to send short data as a new call.

The DMCC may also use the new call pre-emption procedure to pre-empt the gateway during a registration phase.

NOTE: The DM-MS uses the DM-PREEMPT PDU addressed to the master of the channel. The master may be either the gateway or a DM-MS during occupation; it is always the gateway for the reservation period during call set-up through a gateway and for the reservation period after a call transaction; and it is always the gateway during a registration phase. After receiving a DM-PRE ACCEPT PDU, the pre-empting DM-MS obeys the appropriate short data procedure, as defined in the appropriate part of EN 300 396, according to the required communication type.

6.3.1.3 Sending short data during circuit mode transmission

EN 300 396-3 [3], clause 6.3.1.3 shall apply.

6.3.1.4 Sending short data as a transaction within a circuit mode call

A master DM-MS becomes a slave at the end of a circuit mode transmission. Therefore, if the user application initiates short data message transfer relating to an ongoing circuit mode call while the DM-MS is transmitting circuit mode traffic and if the short data cannot be sent during the circuit mode transmission then, at the end of the occupation period, the DM-MS should use the changeover procedure during the reservation period if it wishes to send the short data. Refer to clause 6.3.1.4.2.

If the user application initiates short data message transfer relating to an ongoing circuit mode call, and if the DM-MS is currently a slave in the circuit mode call, then the DMCC may use the pre-emption procedure during occupation, or changeover procedure during reservation, to request to send the short data, refer to clauses 6.3.1.4.1 or 6.3.1.4.2, provided that use of the gateway is not restricted due to URT, see clause 6.6.1.

6.3.1.4.1 Pre-emption to send short data as a transaction within a circuit mode call

EN 300 396-3 [3], clause 6.3.1.4.1 shall apply, except that a DM-MS shall not attempt pre-emption to send short data as a transaction within a circuit mode call if it is only able to monitor the master DM-MS directly in a transaction through a DM-REP/GATE.

NOTE 1: After receiving DM-PRE ACCEPT, the pre-empting DM-MS sends its short data as master of the channel even if the DM-PRE ACCEPT was sent by another DM-MS. This contrasts with the method for a circuit mode call transaction when the pre-empting DM-MS remains a slave until it has received an acceptance from the gateway.

NOTE 2: If a DM-MS performs pre-emption to send short data as a transaction within a circuit mode call when the gateway is master of the channel during circuit mode occupation then DM-MSs will miss some TMO traffic (unknown to the TMO sender). It is therefore recommended that this procedure is not used other than for emergency reasons.

6.3.1.4.2 Changeover to send short data as a transaction within a circuit mode call

EN 300 396-3 [3], clause 6.3.1.4.2 shall apply.

NOTE: The DM-MS sends the DM-TX REQUEST PDU addressed to the gateway, since the gateway is always master during reservation periods.

6.3.1.4.3 Sending the short data as master of the circuit mode call

EN 300 396-3 [3], clause 6.3.1.4.3 shall apply except that the DM-MS is never master during circuit mode reservation and point d) shall be replaced with the following text:

- d) after completion of the short data transfer (or a failure other than pre-emption) then, instead of returning to state IDLE, the DMCC shall enter state CALL ACTIVE RX RESERVATION as a slave DM-MS during reservation and shall follow the procedures defined in clause 6.2.5.2.

6.3.2 Receiving short data

6.3.2.1 Receiving unacknowledged short data

EN 300 396-3 [3], clause 6.3.2.1 shall apply.

NOTE: When the DMCC receives a DM-SDS UDATA message then that message may have been generated by the gateway (i.e. for a short data message originated in the TMO system), or may have been originated by a DM-MS. The latter case may arise, for example, if the calling DM-MS used the unacknowledged service for a group short data message involving both DM and TMO users. It may also arise if the calling DM-MS sent the message using the acknowledged service, requiring an acknowledgement from the gateway; in this case the layer 2 in any local DM-MS addressed by the message converts the received message to a DM-SDS UDATA before issuing it to layer 3, thereby preventing multiple acknowledgements. Refer to clause 8.5.4.2.

6.3.2.2 Receiving acknowledged short data

EN 300 396-3 [3], clause 6.3.2.2 shall apply.

NOTE: When the DMCC receives a DM-SDS DATA message then that message will have been generated by the gateway (i.e. for short data originated in the TMO system).

6.3.3 Additional addressing

6.3.3.1 DM-MS sending short data

For an inter-MNI short data message, or for an intra-MNI short data message if the DM-MS does not wish to use its true ISSI as the layer 2 source address, the DMCC shall provide its ITSI as the "calling party TSI" element within the layer 3 PDU.

The DMCC may include an "area selection" element as a layer 3 element within the layer 3 PDU.

A DM-MS may send a short data message through a DM gateway to a subscriber in an external network (i.e. beyond the TMO system). The DM-SDS DATA or DM-SDS UDATA PDU shall be sent using the external network gateway address as the layer 2 destination address and shall contain the external network subscriber number within the layer 3 PDU.

6.3.3.2 DM-MS receiving short data

If the layer 2 source address was a true SSI then the called DMCC(s) shall use the addressing information provided in the DMA-UNITDATA indication to generate the "calling party TSI" parameter in the DMCC-SDS UNITDATA or DMCC-SDS DATA indication primitive. Otherwise, the called DMCC(s) shall use the additional addressing information provided within the layer 3 PDU to generate the "calling party TSI" parameter in the DMCC-SDS UNITDATA or DMCC-SDS DATA indication primitive.

The called DMCC(s) may also indicate whether the short data message was originated by a DM-MS or generated by the gateway.

If the short data message was generated by the gateway then the additional addressing information within the layer 3 PDU may contain an external subscriber number, which the DMCC shall deliver to the user application in the DMCC-SDS UNITDATA or DMCC-SDS DATA indication primitive.

6.3.4 Extended error protection

EN 300 396-3 [3], clause 6.3.4 shall apply.

6.3.5 SDS-TL service in DMO

EN 300 396-3 [3], clause 6.3.5 shall apply.

6.3.5.1 Service primitives at the DMTL-SAP

EN 300 396-3 [3], clause 6.3.5.1 shall apply with the following additions:

- i) The DMTL-SDS-TRANSFER request primitive may include an "area selection" parameter.
- ii) The DMTL-SDS-TRANSFER request, DMTL-SDS-REPORT request and DMTL-SDS-ACK request primitives may include an "external subscriber number (called)" parameter, comprising up to 24 digits, and hence do include a "called party type identifier".
- iii) The DMTL-SDS-TRANSFER indication, DMTL-SDS-REPORT indication and DMTL-SDS-ACK indication primitives may include an "external subscriber number (calling)" parameter, comprising up to 24 digits, and hence do include a "calling party type identifier".

- iv) The DMTL-SDS-TRANSFER request, DMTL-SDS-TRANSFER indication, DMTL-SDS-REPORT request, and DMTL-SDS-REPORT indication primitives may include an "external subscriber number" as a forward address, comprising up to 24 digits.
- v) Use of the DMTL-SDS-TRANSFER confirm, DMTL-SDS-REPORT confirm and DMTL-SDS-ACK confirm primitives imply only that the short data message has been successfully sent as far as the gateway. It does not imply receipt by the called terminal.

6.3.5.2 DMTL-SDS primitives' parameters

EN 300 396-3 [3], clause 6.3.5.2 shall apply.

6.3.5.3 DMTL-SDS PDUs

EN 300 396-3 [3], clauses 6.3.5.3 and E.2 shall apply.

NOTE 1: A DM-MS may send SDS-TL message via the gateway to the TM-MS, or additionally via a Service Centre by including a forward address. The forward address may also be an external subscriber number. Similarly SDS-TL messages from a TM-MS may be received via a Service Centre.

NOTE 2: If a DM-MS operating with a gateway does not know whether the SwMI supports SDS service centre addressing, and the DM-MS specifies a service centre address in the SDS-TL message, it may be ignored on the SwMI side.

6.3.5.4 DMTL-SDS procedures

EN 300 396-3 [3], clause 6.3.5.4 shall apply, though the figures only illustrate SDS-TL message transfer between DM-MS and gateway.

6.4 Procedures for mobility management

6.4.1 Solicited registration

The user application initiates a registration request by transferring a DMMM-REGISTRATION request primitive across the DMMM-SAP to the DMMM entity. The following procedure applies if the DMMM entity is in state NOT-REGISTERED and has determined that the DM channel is in a registration phase.

If use of the gateway is restricted due to URT, see clause 6.6.1, then the DMMM shall inform the user application with a DMMM-REPORT indication.

Otherwise the DMMM shall send a DM-GREGISTER REQUEST PDU addressed to the gateway and shall enter state WAIT-REGISTRATION. It shall then wait for a response from the gateway:

- If it receives a DM-GREGISTER ACCEPT PDU, it shall enter state REGISTRATION-ACCEPTED, and shall then inform the user application with a DMMM-REGISTRATION confirm.
- If it receives a DM-GREGISTER REJECT PDU, it shall enter state REGISTRATION-REJECTED, and shall inform the user application with a DMMM-REPORT indication.
- If it receives a DMA-REPORT indicating registration access failure, the DMMM shall return to state NOT-REGISTERED and inform the user application with a DMMM-REPORT indication.

The procedure defined above may also be used if the DMMM entity is in state REGISTRATION-ACCEPTED and has determined that the DM channel is in a registration phase except that, in the case of registration access failure, the DMMM may return to state REGISTRATION-ACCEPTED. This procedure may apply if the user application wishes to change the serviced identity (i.e. serviced GSSI).

6.4.2 Unsolicited registration

The user application initiates a registration request by transferring a DMMM-REGISTRATION request primitive across the DMMM-SAP to the DMMM entity. The following procedure applies if the DMMM entity is in state NOT-REGISTERED and has determined that the DM channel is not in a registration phase.

If use of the gateway is restricted due to URT, see clause 6.6.1, then the DMMM shall inform the user application with a MMM-REPORT indication.

Otherwise the DMMM shall send a DM-GREGISTER REQUEST PDU addressed to the gateway. It shall then enter state WAIT-REGISTRATION and shall await DMA-REPORT indication(s) from layer 2, reporting on the progress of the transmission.

- If the DMMM receives a DMA-REPORT indication reporting failure because the channel has become busy, it shall return to state NOT-REGISTERED and inform the user application with a DMMM-REPORT indication.
- If the DMMM receives a DMA-REPORT indication reporting that the DM-GREGISTER REQUEST PDU has been transmitted the appropriate number of times, the DMMM shall start timer DT326 and await a response from the gateway:
 - If it receives a DM-GREGISTER ACCEPT PDU it shall enter state REGISTRATION-ACCEPTED, shall stop timer DT326 and shall then inform the user application of a successful registration with a DMMM REGISTRATION confirm.
 - If it receives a DM-GREGISTER REJECT PDU, it shall enter state REGISTRATION-REJECTED, shall stop timer DT326 and shall inform the user application of registration rejection with a DMMM-REPORT indication.
 - If timer DT326 expires then the DMMM shall either send the DM-GREGISTER REQUEST PDU again or inform the user application with a DMMM-REPORT indication and return to state NOT-REGISTERED. The DMMM shall attempt the registration transmission up to a maximum of DN326 times if no response has been received.

The procedure defined above may also be used if the DMMM entity is in state REGISTRATION-ACCEPTED and has determined that the DM channel is not in a registration phase except that, in the case of failure because the channel has become busy or after DN326 attempts, the DMMM may return to state REGISTRATION-ACCEPTED. This procedure may apply if the user application wishes to change the serviced identity (i.e. serviced GSSI).

6.4.3 Cancellation of registration by gateway

On reception of a DM-GREGISTER CANCEL PDU, the DMMM shall, if not engaged in a registration transaction, send a DM-GCANCEL ACK PDU.

- If the registration reject cause is "no response from SwMI", the DMMM shall enter state NOT-REGISTERED and inform the user application with a DMMM-REPORT indication.
- Otherwise the DMMM shall enter state REGISTRATION-REJECTED and inform the user application with a DMMM-REPORT indication.

6.4.4 Other criteria for DMMM state change

On generation of a DMMM-REPORT indication to the user application the DMMM shall enter the state corresponding to the registration status parameter.

If the registration label is no longer valid then the DMMM shall inform the user application with a DMMM-REPORT indication and shall enter state NOT-REGISTERED.

If the DM-MS becomes registered elsewhere in the TMO system then the DMMM shall enter DM state NOT-REGISTERED.

- NOTE: The DM-MS may become registered elsewhere on the TMO system, for instance, by being switched from DMO to TMO operation.

6.4.5 Action on entering state REGISTRATION-REJECTED

The service that the DM-MS can expect from the gateway while in state REGISTRATION-REJECTED is dependent on the registration result parameter (generated from the registration reject cause element):

- If the registration result is "attachment rejected by SwMI" then the DM-MS should not expect to receive individually addressed calls from the gateway.
- If the registration result is "ITSI not known to gateway" or "request rejected by gateway" then the DM-MS shall not initiate call set-up requests using that gateway address.
- If the registration result is "gateway cannot support requested group" then the DM-MS shall not initiate call set-up requests to that group using that gateway address. The DM-MS may re-attempt registration including a different group address within the DM-GREGISTER REQUEST PDU or without including a group address.

6.4.6 Layer 3 addressing in DM-GREGISTER REQUEST PDU

If the DM-MS does not wish to use its true ISSI as the layer 2 source address (i.e. if it is using pseudo addressing at layer 2) then the DMMM shall provide its ITSI as the "calling party TSI" element within the layer 3 PDU.

If the DM-MS is not providing its ITSI as the "calling party TSI" element within the layer 3 PDU then it may optionally include a group address which it wishes to use. It shall provide this group address as the "serviced GSSI" element within the layer 3 PDU.

NOTE: If the DM-MS does not include the serviced GSSI (either because it needs to include its ITSI within the layer 3 PDU or because it chooses not to include a GSSI), this does not necessarily mean that the DM-MS is not using a GSSI. If the DM-MS includes a GSSI, this does not necessarily mean that it is the only GSSI that the DM-MS wishes to use.

6.5 Usage of DMA-UNITDATA primitive

6.5.1 Sending a DMCC PDU

When clauses 6.2 and 6.3 refer to the DMCC "sending a PDU", the DMCC shall give the PDU to layer 2 in a DMA-UNITDATA request primitive. It shall use the procedure described in EN 300 396-3 [3], clause 6.4 except that:

- i) when sending a gateway-specific PDU (i.e. DM-GSETUP, DM-GPREEMPT, DM-GTX REQUEST), the DMCC supplies both the "message type" and the "gateway message subtype" in the DMA-UNITDATA request;
- ii) for a DM-GTX REQUEST, the DMCC shall indicate in the DMA-UNITDATA request whether the message is being sent after a successful pre-emption of a master DM-MS (so that non-contentious access applies) or whether random access applies.

6.5.2 Sending a DMMM PDU

When clause 6.4 refers to the DMMM "sending a PDU", the DMMM shall give the PDU to layer 2 in a DMA-UNITDATA request primitive. It shall construct the DM-SDU as defined in clause 14 and shall provide the DM-SDU, "message type" and "gateway message subtype" as parameters in the primitive. Also, when sending a DM-GREGISTER REQUEST message, the DMMM shall indicate in the DMA-UNITDATA request whether the registration request is solicited or unsolicited.

6.5.3 Protocol control function for delivery of received message

When layer 2 receives a message addressed to this DM-MS, it delivers the message to layer 3 in a DMA-UNITDATA indication primitive. The DM-MS shall use the "message type" and "gateway message subtype" parameters to decide whether the message should be routed to the DMCC or the DMMM entity. Messages DM-GREGISTER ACCEPT, DM-GREGISTER REJECT and DM-GREGISTER CANCEL shall be routed to the DMMM entity. All other recognizable messages shall be routed to the DMCC entity.

6.6 General procedures

6.6.1 Usage restriction type and validity time

The usage restriction type, addressing for URT and validity time elements are passed from layer 2 to layer 3 using DMC-REPORT indication in the "presence signal information" parameter, when received in the gateway presence signal.

If "usage restriction type" = 0000₂ (no restrictions), then this places no restrictions on the DM-MS using the gateway.

If "usage restriction type" = 0001₂ (restricted by prior arrangement), then the DM-MS shall only use the gateway if by configuration or otherwise it knows that it is permitted to use the gateway.

If "usage restriction type" = 1000₂ to 1011₂, then the DM-MS shall decrypt the address information as defined in EN 300 396-6 [6].

If "usage restriction type" = 0010₂ to 1011₂, then the DM-MS shall use the address information as defined in clause 14.3 to determine when it is permitted to use the gateway as follows:

- if the address information corresponds to one of its addresses and the validity time is non-zero, then the use of the gateway by the DM-MS should not be restricted for the specified validity time; the DM-MS should start or restart a validity time timer and when this expires the use of the gateway by the DM-MS should be restricted;
- if the address information corresponds to one of its addresses and the validity time is zero, then the use of the gateway by the DM-MS should be restricted immediately;
- if the address information cannot be decrypted or does not correspond to any of its addresses, then there should be no change to the restriction on the DM-MS using the gateway.

If the use of the gateway by the DM-MS becomes restricted then any transaction that it is attempting to set up shall be abandoned cleanly and any ongoing transaction that it initiated shall be cleared down as described in the earlier parts of this clause 6. While restricted the DM-MS shall not initiate any new transactions through the gateway, however it is permitted to receive incoming transactions, including responding to acknowledged transactions when it is individually addressed, and it is permitted to pre-empt gateway transactions to initiate a transaction not involving the gateway.

Prior to receiving usage restriction type and validity time from a specific gateway, if the DM-MS is configured to use that gateway or it receives signalling messages from the gateway addressed to itself, the DM-MS may assume that there are no restrictions on its use of the gateway, unless configured to assume that its use is restricted prior to receipt of a presence signal.

NOTE: The gateway should not ignore messages from DM-MS based on URT and validity time in any way that prevents DM-MS from clearing down transactions cleanly or pre-empting transactions for new calls.

7 DM-MS layer 2 service description (for operation with a gateway)

7.1 Introduction

The following clauses describe the services offered by the DM-MS's layer 2 to its layer 3 for operation with a gateway – either a DM-GATE, type 1A DM-REP/GATE or type 1B DM-REP/GATE. The service description is described in terms of Service Access Points (SAPs), primitives and their parameters.

The internal boundaries between the layers and sub-layers described herein are not testable and do not imply any specific implementation, but are rather used for the description of the protocol model. In the following clauses the word "shall" is used with SAPs, service primitives and parameters for traceability reasons in the protocol model, but again those SAPs and primitives are not testable. The following description also does not imply any specific implementation.

NOTE: In an implementation, additional parameters may be included in the primitives in order to exchange additional information between layers 3 and 2.

7.2 Layer 2 architecture

EN 300 396-3 [3], clause 7.2 shall apply except that, for operation with a gateway, layer 2 provides services to both the DMCC and DMMM entities in layer 3 (through the DMA-SAP and DMC-SAP).

7.3 Service descriptions

7.3.1 Services at the DMA-SAP

7.3.1.1 Services provided to layer 3

EN 300 396-3 [3], clause 7.3.1.1 shall apply.

NOTE 1: This clause applies without change, even for operation through a DM-REP/GATE. This contrasts with EN 300 396-4 [4] in which, for set-up messages for new calls, layer 2 is required to look for the repeated message on the slave link in order to check whether or not the link to the DM-REP has been established. This difference for circuit mode calls is because, for operation through a DM-REP/GATE, a DM-MS sending DM-SETUP messages has only just received a DM-GCONNECT message from the DM-REP/GATE (or a DM-GTX ACCEPT or DM-GPRE ACCEPT message for changeover or pre-emption). In an implementation, the DM-MS is not precluded from looking for the repeated DM-SETUP message on the slave link and releasing the call if the repeated message is not received.

NOTE 2: For short data messages sent through a DM-REP/GATE, the DM-MS may choose to monitor the slave link to deduce the success or failure of link establishment to the DM-REP/GATE. This may be found particularly useful for unacknowledged short data messages. However, it is not a mandatory requirement. Refer to clause 8.5.4.1.

7.3.1.2 Service primitives at the DMA-SAP

7.3.1.2.1 DMA-REPORT primitive

EN 300 396-3 [3], clause 7.3.1.2.1 shall apply.

7.3.1.2.2 DMA-UNITDATA primitive

EN 300 396-3 [3], clause 7.3.1.2.2 shall apply with the following differences:

- i) The DMA-UNITDATA primitive shall have the following additional parameters:
 - parameter "gateway generated message flag": not used in request, mandatory in indication;
 - parameter "gateway message subtype": conditional in both request and indication;
 - parameter "DM-GTX REQUEST after pre-emption": conditional in request, not used in indication;
 - parameter "type of registration request": conditional in both request and indication.
- ii) The destination address parameter shall be conditional in the DMA-UNITDATA request primitive and the source address parameter shall be conditional in the DMA-UNITDATA indication. (These parameters are not included for transmission and reception of gateway-specific messages).

7.3.2 Services at the DMC-SAP

7.3.2.1 Services provided to layer 3

The DMC-SAP is used for the transfer of local layer management information. It may be used, for example, for layer 3 to instruct layer 2 to reconfigure its parameters or for layer 2 to issue reports on the perceived state of the channel (enabling correct behaviour of layer 3). It is also used for layer 2 to indicate to the higher layers when layer 2 is receiving a gateway presence signal from a gateway that the DM-MS is permitted to use.

7.3.2.2 Service primitives at the DMC-SAP

7.3.2.2.1 DMC-CONFIGURE primitive

EN 300 396-3 [3], clause 7.3.2.2.1 shall apply except that the DMC-CONFIGURE request primitive may have additional conditional parameters "gateway address" and "type of gateway".

7.3.2.2.2 DMC-REPORT primitive

EN 300 396-3 [3], clause 7.3.2.2.2 shall apply with the following differences:

- i) The DMC-REPORT indication shall have an additional conditional parameter "presence signal information". This parameter is used for layer 2 to provide appropriate information to the higher layers about received gateway presence signals.
- ii) The DMC-REPORT indication is used to issue five additional types of report on the status of the channel, not required for direct MS-MS operation:
 - It is used, during circuit mode calls, for the layer 2 in slave DM-MSs to report whether the gateway or a DM-MS is currently master of the DM channel.
 - It is used, during circuit mode occupation, for the layer 2 in the master DM-MS to report to layer 3 that the link to the gateway has failed or that the channel is in reservation for the call.
 - It is used, during reservation for call set-up, for the layer 2 in a calling or called DM-MS to report that the channel has been lost e.g. because the gateway has accepted a pre-emption request from another DM-MS.
 - It is used for layer 2 to indicate to layer 3 when the DM channel is in a registration phase. Then parameter "priority of ongoing call" indicates the priority of that registration phase (enabling the DMCC to decide whether pre-emption is valid).
 - It is used for layer 2 to inform layer 3 when a gateway is present and to pass on parameters from the gateway presence signal including those that indicate if the gateway is usable.

7.3.3 Services at the DMD-SAP

7.3.3.1 Services provided to the U-plane application

EN 300 396-3 [3], clause 7.3.3.1 shall apply.

7.3.3.2 Service primitives at the DMD-SAP

EN 300 396-3 [3], clause 7.3.3.2 shall apply.

7.4 Parameter listing

EN 300 396-3 [3], clause 7.4 shall apply with the following differences:

- i) Parameter "immediate retransmission" may be used also for a retransmission of DM-GSETUP, to indicate whether the message should be sent immediately (as a slave transmission) without further checking that the channel is free.
- ii) Parameter "priority of ongoing call" may be used also when the DM channel is in use for a registration phase, enabling the DMCC to decide whether pre-emption is valid.
- iii) Parameter "report" has additional values to indicate registration access success and registration access failure.

NOTE 1: The "communication type" parameter in the DMA-UNITDATA request primitive for a call set-up message enables layer 3 to specify whether the gateway function is required for the call – thereby invoking operation according to this part of the present document. This applies particularly for a short data message (since other types of call set-up through a gateway are requested using a gateway-specific message).

The following definitions shall also apply.

DM-GTX REQUEST after pre-emption

This parameter is used in the DMA-UNITDATA request primitive for layer 3 to specify, for a DM-GTX REQUEST message, whether the message follows successful pre-emption of a DM-MS or whether random access applies. Layer 2 shall use this parameter to deduce the method of transmission of the message, and shall include this parameter when it constructs the message.

Gateway address

This parameter in the DMC-CONFIGURE request primitive configures layer 2 with the 10-bit gateway address.

Gateway generated message flag

This parameter is used in the DMA-UNITDATA indication primitive for layer 2 to indicate to layer 3 whether the message was generated by the gateway or originated by a DM-MS.

NOTE 2: When re-transmitting a DM-MS's message on the DM channel, a DM-REP/GATE leaves the "gateway generated message flag" element unchanged (i.e. indicating that the message was originated by a DM-MS).

Gateway message subtype

This parameter is used in the DMA-UNITDATA request primitive for layer 3 to specify, for a gateway-specific message, the subtype of the PDU to be sent. Layer 2 shall include the gateway message subtype when it constructs the message.

This parameter is also used in the DMA-UNITDATA indication primitive for layer 2 to indicate to layer 3 the message subtype for a received gateway-specific message.

Presence signal information

This parameter is used in the DMC-REPORT indication primitive for layer 2 to provide appropriate information to the higher layers (e.g. the DMMM entity in layer 3) about received gateway presence signals.

Type of gateway

This parameter in the DMC-CONFIGURE request primitive configures layer 2 with information about the gateway type (i.e. DM-GATE, type 1A DM-REP/GATE or type 1B DM-REP/GATE).

Type of registration request

This parameter is used in the DMA-UNITDATA request primitive for layer 3 to specify, for a DM-GREGISTER REQUEST message, whether the registration request is solicited or unsolicited. Layer 2 shall then include the parameter as a message-dependent element when it constructs the message.

This parameter may also be used in the DMA-UNITDATA indication primitive when layer 2 delivers a received DM-GREGISTER ACCEPT or DM-GREGISTER REJECT message to layer 3.

8 DM-MS layer 2 protocol (for operation with a gateway)

8.1 Introduction

EN 300 396-1 [1], clause 5 provides a brief overview of the general architecture and a description of all layers within the DMO protocol including the functionality of the data link layer. The following clauses describe in detail the layer 2 protocol and define the operation of the data link layer in a DM-MS operating with a gateway – either a DM-GATE, type 1A DM-REP/GATE or type 1B DM-REP/GATE.

NOTE 1: A gateway can support only a single call on the air interface. Therefore the DM-MS protocol for operation with a gateway is based on the protocol for normal mode in EN 300 396-3 [3].

NOTE 2: For operation with a DM-GATE or type 1A DM-REP/GATE, all DM transmissions are sent on the selected DM RF carrier.

NOTE 3: The procedures for operation with a type 1B DM-REP/GATE are similar to the procedures for operation with a type 1A DM-REP/GATE except that transmissions by DM-MSs are sent on the appropriate DM "uplink" RF carrier f_1 and transmissions from the DM-REP/GATE to DM-MSs are sent on the associated (duplex-spaced) DM "downlink" RF carrier f_2 .

The data link layer in the DM-MS is divided into two sub-layers: the upper MAC and the lower MAC.

8.1.1 Functions of lower MAC

EN 300 396-3 [3], clause 8.1.1 shall apply.

See clause 15 for specific details of the lower MAC functionality.

8.1.2 Functions of upper MAC

EN 300 396-3 [3], clause 8.1.2 shall apply.

The functions of the upper MAC are described in this clause.

8.2 Interface between lower and upper MAC

8.2.1 Logical channels defined at the DMV-SAP

EN 300 396-3 [3], clause 8.2.1 shall apply.

8.2.2 Service primitives at the DMV-SAP

EN 300 396-3 [3], clause 8.2.2 shall apply.

8.2.3 PDU mapping of the logical channels at the DMV-SAP

EN 300 396-3 [3], clause 8.2.3 shall apply.

8.2.4 Scrambling mechanism

The scrambling method applied in TETRA DM is defined in EN 300 396-2 [2], clause 8.2.5, and is based on a "seed" – the DM Colour Code (DCC).

The DCC for SCH/F, STCH and TCH shall be a 30-bit sequence $e(1)$, $e(2)$ to $e(30)$, generated as an algorithmic combination of the "source address" element and the 6 least significant bits of the 10-bit "gateway address" element. The coding order shall be as follows:

- $e(1)$ = 6th last bit of the gateway address;
- $e(2)$ = 5th last bit of the gateway address;
- etc.
- $e(6)$ = least significant bit of the gateway address;
- $e(7)$ = most significant bit of source address;
- etc.
- $e(30)$ = least significant bit of source address.

The colour code for STCH or TCH shall be derived from the "gateway address" and "source address" elements in the DMAC-SYNC PDU that carried the DM-SETUP, DM-CONNECT ACK or DM-OCCUPIED message for the current traffic transmission. The colour code for SCH/F shall be derived from the "gateway address" and "source address" elements in the DMAC-SYNC PDU that initiated the fragmentation; this may apply to DM-GSETUP, DM-SDS UDATA, DM-SDS DATA and DM-SDS ACK messages.

NOTE: The "source address" element may contain either a true SSI or a pseudo SSI. The algorithmic combination described above applies in either case.

When element "air interface encryption state" is set to 01_2 (security class DM-2-C) in the DMAC-SYNC PDU, the addressing information is encrypted except the 10-bit gateway address (see clause 8.5.3). The following parameters shall be used for the generation of the DCC:

- the "gateway address" element; and
- the Encrypted DMO Short Identity (EDSI) appropriate to the current slot (see EN 300 396-6 [6]). The EDSI is an encrypted version of the source address from the DMAC-SYNC PDU that carried the DM-SETUP, DM-CONNECT ACK or DM-OCCUPIED message for the current traffic transmission, or from the DMAC-SYNC PDU that initiated the fragmentation. The EDSI changes from one slot to the next, because it is derived using the Time Variant Parameter (TVP) for that slot, so the DCC also changes for each traffic or SCH/F slot.

The scrambling sequence is generated from the 30-bit DCC and is applied within the lower MAC to all logical channels, except for the SCH/S and SCH/H of the DSB. SCH/S and SCH/H of the DSB are subjected to the same scrambling but, in their case, all 30 bits of the DCC are set equal to zero.

8.2.5 PDU error detection

EN 300 396-3 [3], clause 8.2.5 shall apply.

8.2.6 Modes of operation

EN 300 396-3 [3], clause 8.2.6 shall apply.

8.3 Basic capabilities of the physical layer

8.3.1 DM-MS capabilities

The following clauses describe the capabilities required of DM-MSs for operation with a gateway. DM-MSs are classified as either DM only DO-MS, dual mode capable DU-MS or dual watch capable DW-MS.

8.3.1.1 DM only and dual mode capable MS operation

For operation with a DM-GATE or type 1A DM-REP/GATE, a DO-MS or DU-MS shall be capable of either transmitting or receiving (i.e. simplex mode operation) on a single DM RF carrier.

For operation with a type 1B DM-REP/GATE, the DO-MS or DU-MS shall be capable of either transmitting on one DM RF carrier (the "uplink" frequency f_1 from DM-MSs to the DM-REP/GATE) or receiving on a different DM RF carrier (the "downlink" frequency f_2 from the DM-REP/GATE to DM-MSs), in two-frequency simplex mode.

In either case, the DO-MS or DU-MS shall be capable of switching between DM transmit and receive within one timeslot duration.

A DO-MS or DU-MS shall be capable of transmitting in all four timeslots of at least two consecutive frames. If a DO-MS or DU-MS is capable of sending non-fragmented DM-SDS DATA messages then it shall be capable of transmitting in at least 11 consecutive slots.

A DM-MS that is operating as a master MS shall be capable of adjusting its current transmit timing reference in steps of 1/4 symbol duration, as defined in clauses 8.4.1.2 and 15.

A DO-MS or DU-MS shall be capable of adjusting its transmission frequency as defined in clause 15.

8.3.1.2 Dual watch capable MS operation

The present document does not support dual watch operation by a DM-MS operating with a gateway.

If a DW-MS chooses to operate with a gateway instead of using its dual watch capability then it shall support the operations described in clause 8.3.1.1.

NOTE: It is not precluded to implement a DW-MS which operates with a gateway and also uses its dual watch capability. However the present document does not identify or resolve any possible conflicts. In particular the normal dual watch synchronization timing is not compatible with the DM channel timing likely to be used for calls through a gateway.

8.4 Usage of DM channel with gateway

A DM channel may be perceived as being free, occupied, reserved or in a registration phase. Otherwise the state of the DM channel may be unknown.

When the DM channel is in occupation or reservation or in a registration phase, there is a timing structure which is divided into multiframes, frames and timeslots. In the channel free condition, and if the gateway provides a DM gateway presence signal, then that presence signal provides the DM timing reference.

In DM-GATE operation, all transmissions on the DMO side are sent on the selected DM RF carrier. All communications between the DM-GATE and DM-MSs, and between DM-MSs, shall use the same frame and slot numbering. When a DM-MS is transmitting, other DM-MSs on the channel receive messages or traffic directly, without the intervention of the DM-GATE.

In DM-REP/GATE operation, during call transactions in which a DM-MS is master of the DM channel, the DM-REP/GATE performs a DM repeater function, re-transmitting the information to the slave DM-MSs:

- all communications between the DM-REP/GATE and the master DM-MS, on the master link, shall use the master link's slot and frame numbering a slave or idle DM-MS that is monitoring the master DM-MS on the master link may use the master link's slot and frame numbering;

- all communications between the DM-REP/GATE and slave or idle DM-MSs, on the slave link, shall use the slave link's slot and frame numbering;
- the slot and frame numbering on the slave link lags three timeslots behind the master link's slot and frame numbering.

During call transactions in which the DM-REP/GATE is master of the DM channel, during all reservation periods and during registration phases, communications between the DM-REP/GATE and DM-MSs shall use the slave link's slot and frame numbering.

For operation with a type 1A DM-REP/GATE, all transmissions on the DMO side are sent on the selected DM RF carrier. This applies to both master link and slave link transmissions.

For operation with a type 1B DM-REP/GATE, all transmissions from the DM-REP/GATE to DM-MSs are sent on the selected DM downlink RF carrier f_2 . Apart from when pre-empting for new call by sending directly to a master DM-MS on the DM downlink RF carrier f_2 , all transmissions by DM-MSs are sent on the associated (duplex-spaced) DM uplink RF carrier f_1 . This applies to both master link and slave link transmissions.

8.4.1 Definition of DM channel

8.4.1.1 DM channel arrangement

8.4.1.1.1 DM channel arrangement for operation with a DM-GATE

A DM channel existing during occupation, reservation or a registration phase consists of two timeslots on a single DM RF carrier, each timeslot lasting for 14,167 ms. The end of one DM channel timeslot and the beginning of the other timeslot associated with the DM channel are separated in time by one timeslot duration. Time on the DM channel is further divided into frames and multiframe, each frame equal to 4 timeslots duration and each multiframe equal to 18 frames duration (see EN 300 396-2 [2], clause 9 for further details).

8.4.1.1.2 DM channel arrangement for operation with a type 1A DM-REP/GATE

For operation with a type 1A DM-REP/GATE, a DM channel exists on a single DM RF carrier.

When a DM-MS is master it is divided, in time, into master link timeslots and slave link timeslots (as in EN 300 396-4 [4]). Two timeslots are allocated primarily for the master link and two timeslots primarily for the slave link. Each timeslot lasts for 14,167 ms. The end of one master link timeslot and the beginning of the other are separated in time by one timeslot duration. The slave link timeslots are similarly arranged. Time on the DM channel is further divided into frames and multiframe, each frame equal to 4 timeslots duration and each multiframe equal to 18 frames duration.

When the DM-REP/GATE is master, the same arrangement shall apply. However no signalling is sent or received on the master link.

NOTE: For calls using a gateway, the gateway is always master during reservation periods (either during call set-up or after a call transaction). Therefore no signalling is sent on the master link during reservation.

The gateway is also master during call transactions originated in the TMO system. Therefore no traffic or signalling is sent on the master link during occupation for call transactions from TMO.

The gateway is master when soliciting registration requests i.e. during a registration phase. Therefore no signalling is sent on the master link during a registration phase.

8.4.1.1.3 DM channel arrangement for operation with a type 1B DM-REP/GATE

For operation with a type 1B DM-REP/GATE, the same DM channel arrangement shall apply as for a type 1A DM-REP/GATE except that transmissions by DM-MSs are sent on the DM uplink RF carrier f_1 whereas transmissions from the DM-REP/GATE to DM-MSs are sent on the DM downlink RF carrier f_2 .

8.4.1.2 DM channel operation

A DM-MS wishing to begin a call through a gateway, and having determined that the selected DM RF carrier is free, may transmit its call set-up message using the appropriate type of MS operation:

- For a circuit mode call, the DM-MS shall send its gateway call set-up message DM-GSETUP using slave MS operation. (It does not use master MS operation until it sends the DM-SETUP messages).
- For a short data message, the DM-MS shall send the DM-SDS DATA or DM-SDS UDATA message using master MS operation.
- For an unsolicited registration (i.e. a registration request sent outside a registration phase), the DM-MS shall send the DM-GREGISTER REQUEST message using master MS operation.

When the DM-MS starts to transmit on a free channel, and if the gateway has provided a DM gateway presence signal (or other suitable signalling) on the selected channel, then the DM-MS shall use the slot timing and the slot and frame numbering defined by the gateway. If the DM-MS has not received a DM gateway presence signal (or other suitable signalling) sufficiently recently then it shall choose a timing reference arbitrarily.

NOTE 1: For operation with a DM-REP/GATE, if the DM-MS has received signalling from the gateway on the slave link and then wishes to send a message using slave MS operation, it uses the slave link slot and frame numbering defined by the gateway; if it wishes to send a message using master MS operation, it should set the master link's slot and frame numbering three timeslots ahead of the received slave link numbering.

NOTE 2: If the DM-MS has not received a DM gateway presence signal on the channel and it chooses to use the timing from a previous call, then the new call may use a timing that is not suitable for the gateway, i.e. if the gateway misses the transaction setup signalling then the gateway may not be able to tell that the channel is occupied.

Channel reservation periods occur during call set-up to or from a gateway and usually occur after call transactions. During these reservation periods the gateway is master of the DM channel and the gateway may modify the slot timing or redefine the slot and frame numbering as described in clauses 8.4.7.17 and 8.4.7.18.

When the gateway is transmitting traffic or short data from TMO during channel occupation, the gateway is master of the DM channel.

When a DM-MS is transmitting traffic or short data during channel occupation, that DM-MS is master of the DM channel. However, it shall monitor for gateway transmissions in slot 3 of frames 1, 7 and 13 in order to acquire timing synchronization information and subsequently re-align its transmission timing. The master DM-MS shall re-align its transmission timing if it perceives a difference of more than 1/4 symbol between its own timing and the timing of DSBs received from the gateway; refer to clause 15.

The gateway is master of the DM channel during a registration phase.

When the DM-MS starts to transmit on a free channel, and if the gateway has provided a presence signal (or other suitable signalling) on the selected channel, then the DM-MS should take its initial frequency synchronization from the gateway signalling. If the DM-MS has not received a presence signal (or other suitable signalling) sufficiently recently then it shall use its own internal reference to generate the transmission frequency. In either case, after receiving DSBs from the gateway, the DM-MS re-aligns its frequency synchronization as defined in clause 15.

NOTE 3: Frequency efficient mode is not supported for transactions through a gateway. DM-MSs are not precluded from using the RF carrier in frequency efficient mode for direct MS-MS calls when the gateway is in idle mode between calls. Note however that there is no procedure for pre-empting a frequency efficient direct MS-MS call in order to make a normal mode call (such as a call through a gateway) so use of this option will stop gateway operation until the RF carrier is completely free.

8.4.2 DM-MAC states

The MAC layer of the DM-MS is responsible for monitoring activity on a selected DM RF carrier in order to determine the current perceived state of that RF carrier and to receive any signalling messages addressed to itself (i.e. addressed to its individual address or to one of its group addresses). Accurate DM channel state information is essential if a DM-MS is to employ the correct signalling and monitoring procedures when it is in a call or if it wishes to use fast call set-up.

The perceived DM channel state combined with the current DM-MS mode of operation shall be used to update the DM-MAC state model.

NOTE: For operation with a type 1B DM-REP/GATE, the DM-MS determines the perceived state of the selected DM downlink RF carrier f_2 .

8.4.2.1 DM-MAC state definitions

The following states are defined for the DM-MAC, based on its own activity and the current state of the channel. These shall be used to determine which procedure the DM-MAC follows at any point in time.

MS idle – state of channel unknown:

- The DM-MS is currently operating in idle mode and does not know the state of the channel. This state applies at the following times:
 - following initial power-up in direct mode or when the DM-MS has just been switched into direct mode operation or when the user has just selected a different DM RF carrier; or
 - if the DM-MS has not been performing the fast call set-up surveillance procedures.

The DM-MS also enters this state at other times when required by the protocol e.g. following expiry of inactivity timers DT207 and DT221.

MS idle – channel free:

- The DM-MS is currently operating in idle mode on a channel which is perceived as free i.e. no DMO activity is detected on the channel (other than possible receipt of presence signals indicating that the channel is free).

MS idle – channel occupied:

- The DM-MS is currently operating in idle mode on a channel which is perceived as being occupied i.e.:
 - DMO signalling or traffic information not addressed to the DM-MS (or for a call not accepted by the DM-MS) is detected on the channel; or
 - DSBs that cannot be decrypted or are not understood are detected on the channel; or
 - the DM-MS detects other activity on the channel (see clauses 8.4.2.2.1.1 and 8.4.2.2.2.1).

MS idle – channel reserved:

- The DM-MS is currently operating in idle mode on a channel which is perceived as being reserved i.e. channel reservation signalling which is not addressed to the DM-MS (or is for a call not accepted by the DM-MS) detected on the channel. This reservation signalling may relate either to other DM-MSs' call set-up to or from the gateway or to a channel reservation period after a call transaction. The reservation type is indicated by the "channel reservation type" element in DM-RESERVED messages.

NOTE: A reservation period during call set-up may be announced by the DM-RESERVED message with "channel reservation type" element set to 1, or may be announced by the DM-GACK message with "reservation announced" element set to 1.

As in EN 300 396-3 [3], a reservation period after a call transaction is announced by the DM-TX CEASED message or by the DM-RESERVED message with "channel reservation type" element set to 0.

MS idle – channel in registration phase:

- The DM-MS is receiving gateway presence signals indicating a registration phase from its own or another gateway and is not attempting to send a registration request to the gateway.

MS master – channel occupied:

- The DM-MS is the current master transmitter which is active in a call transaction either in traffic or signalling mode. This may be a circuit mode traffic transmission, a short data transmission (DM-SDS UDATA or DM-SDS DATA), or an unsolicited registration.

MS slave – channel occupied:

- The DM-MS is actively receiving traffic and/or signalling information from the current master and addressed to itself (i.e. addressed to its individual address or to one of its group addresses). This may be a circuit mode traffic transmission, a short data transmission, or a registration cancellation.

MS slave – channel reserved:

- The DM-MS is receiving channel reservation signalling from the gateway and addressed to itself. This state applies for channel reservation following a call transaction in a call involving that DM-MS. It applies also for channel reservation while the DM-MS is setting up a call through the gateway (i.e. after sending DM-GSETUP) or while the gateway is setting up a call with presence check to the DM-MS.

MS slave – channel in registration phase:

- The DM-MS is receiving gateway presence signals indicating a registration phase and is attempting to send a registration request to the gateway or waiting for a response from the gateway.

8.4.2.2 DM-MS channel surveillance procedures

A DM-MS in idle mode shall conduct the appropriate following channel surveillance procedures on the selected DM RF carrier in order to determine the current DM channel state. Surveillance procedures may vary dependent upon the current operation of the DM-MS.

There are two possible methods of channel surveillance:

- a) If fast call set-up shall be provided, then, when in idle mode, the DM-MS needs to maintain an up-to-date record of the perceived state of the channel, so that it already knows whether the channel is free when the user wishes to make a call. The DM-MS shall perform initial determination of the DM channel state (see clause 8.4.2.2.1) and then obey the fast call set-up surveillance procedures defined in clause 8.4.2.2.2.
- b) Where fast call set-up is not required, the DM-MS when in idle mode is not required to maintain an up-to-date record of the perceived state of the channel. The DM-MS then needs to perform initial determination of the DM channel state when the user wishes to make a call.

When idle, the DM-MS should perform some channel surveillance on the DM RF carrier if it wishes to receive calls addressed to itself. The implementer may choose when the DM-MS performs channel surveillance.

NOTE 1: For operation with a type 1B DM-REP/GATE, the DM-MS performs the channel surveillance procedures on the selected DM downlink RF carrier f_2 .

NOTE 2: The standard does not preclude that a DM-MS may undertake to conduct channel surveillance on more than one DM RF carrier. However, the ability to maintain fast call set-up status on more than one DM RF carrier is implementation-specific. For example, in some implementations, a DM-MS could choose to perform the fast call set-up surveillance procedures on one DM RF carrier and just monitor the other DM RF carrier(s) for incoming calls for itself.

8.4.2.2.1 Initial determination of DM channel state**8.4.2.2.1.1 Initial determination of state of carrier**

EN 300 396-3 [3], clause 8.4.2.2.1.1 shall apply.

NOTE: A DM-MS is permitted to implement a signal strength threshold where the DM-MS need not regard the channel as busy (i.e. occupied, reserved or in a registration phase) or re-enter state "MS idle – state of channel unknown" as a result of receiving DSBs below that threshold. If the DSB can be decoded the threshold used may depend on the power class the DSBs were transmitted with and the DM-MS's transmit power capability. However, if the received DSBs contain the gateway address of the gateway used by the DM-MS, the DM-MS should not try to make a call or registration to the gateway while the gateway is active.

8.4.2.2.1.2 Determination of state of one DM channel when other DM channel is busy

Frequency efficiency mode is not valid for transactions through a gateway.

8.4.2.2.2 Fast call set-up surveillance in idle mode

Clauses 8.4.2.2.2.1 and 8.4.2.2.2.2 define the requirements for fast call set-up surveillance following initial determination of the DM channel state. If the DM-MS fails to perform any of these procedures, it shall enter state "MS idle – state of channel unknown".

There are no mandatory surveillance procedures for a DM-MS using slow call set-up surveillance until the DM-MS wishes to make a call. However, if the DM-MS has not fulfilled all the requirements for fast call set-up surveillance since it last knew the state of the channel, it shall enter state "MS idle – state of channel unknown". The DM-MS then needs to perform the procedure for initial determination of the DM channel state when the user wishes to make a call (see clause 8.4.2.2.3).

8.4.2.2.2.1 Fast call set-up surveillance when idle on a free carrier

Following initial determination of the channel state, a DM-MS in idle mode shall periodically conduct further channel surveillance in order to detect any DSBs present on the DM RF carrier and (where signal strength and channel conditions permit) decode any layer 2 information available.

In order to support fast call set-up through a gateway, the DM-MS in idle mode when the carrier is perceived as being free shall be capable of detecting and (where signal strength and channel conditions permit) decoding at least one DSB from a sequence of 6 DSBs sent as three DSBs in each of two frames, where the timing of the sequence of DSBs is arbitrary. The DM-MS may assume that the DSBs are sent in the same three timeslots in each of the two frames.

NOTE 1: This monitoring normally allows the DM-MS to receive a call set-up transmitted by a gateway. Otherwise the DM-MS could erroneously perceive the channel as free and then make a call set-up on the channel, transmitting over the gateway call. This would disrupt the gateway call. Also the DM-MS's own call would be disrupted by the gateway call.

A DM-MS shall update the DM-MAC state model if it detects and decodes a DSB which indicates that the channel state has changed (see clause 8.4.3.3).

In the case where a DSB is detected and can be decoded, but the message type cannot be decrypted, the DM-MS shall either regard the channel as occupied by other DM-MSs or shall enter state "MS idle – state of channel unknown".

In the case where a DSB is detected and can be decoded, but the SYNC PDU type or message type is not understood, the DM-MS shall either regard the channel as occupied by other DM-MSs or shall enter state "MS idle – state of channel unknown".

NOTE 2: The DM-MS is permitted to implement a signal strength threshold where it need not regard the channel as busy or enter state "MS idle – state of channel unknown" as a result of receiving DSBs below that threshold. For example, the signal strength threshold may be set to the receiver sensitivity level. However, if the received DSBs contain the gateway address of the gateway used by the DM-MS, the DM-MS should not try to make a call or registration to the gateway while the gateway is active.

NOTE 3: The DM-MS may change its perception of the channel state and update the DM-MAC state model as a result of conducting additional channel surveillance procedures e.g. signal strength measurements.

The DM-MS may also change its perception of the channel state and update the DM-MAC state model if it recognizes that it is receiving TMO signalling.

8.4.2.2.2.2 Fast call set-up surveillance when idle on a carrier that is not free

When the DM channel is occupied in a call through a gateway or in a registration phase, fast call set-up surveillance shall consist of performing the following procedure:

- 1) The DM-MS shall monitor and attempt to decode a DSB in timeslot 3 at least every two frames. Monitoring of timeslot 3 of frame 3 does not contribute to fulfilling this requirement. The monitoring shall include timeslot 3 of frames 6, 12 and 18.

NOTE 1: For example, this requirement may be met by monitoring timeslot 3 of every even-numbered frame.

When the DM channel is reserved in a call through a gateway, fast call set-up surveillance shall consist of performing the following procedure:

- 2) The DM-MS shall monitor and attempt to decode a DSB in timeslots 1 and 3 at least every two frames. Monitoring of timeslot 3 of frame 3 does not contribute to fulfilling this requirement. The monitoring shall include timeslots 1 and 3 of frames 6, 12 and 18.

NOTE 2: The monitoring of timeslots 1 and 3 is in case the gateway redefines the slot and/or frame numbering.

If an idle DM-MS is conducting the fast call set-up surveillance procedure and receives a message which indicates that a DM channel is busy, then it shall assume that the DM channel is still busy until it receives a message which indicates that the channel state has changed or until the appropriate timer expires (i.e. DT207, reservation time remaining, SDS time remaining or registration phase time remaining). See clause 8.4.3.3.

A DM-MS shall update the DM-MAC state model if it receives a message which indicates that the channel state has changed (see clause 8.4.3.3).

8.4.2.2.3 DM-MS channel surveillance at call set-up (circuit mode call or short data message)

EN 300 396-3 [3], clause 8.4.2.2.3 shall apply for transmission of DM-GSETUP, DM-SDS DATA and DM-SDS UDATA messages. The first randomization procedure (i.e. choosing an integer R randomly from the range DN204 to DN205) shall apply also for a time DT205 after the end of a registration phase.

The exception for the case of new call pre-emption acceptance (i.e. choosing an integer R randomly from the range DN204 + 8 to DN205 + 8) shall apply in the case that a DM-MS observes a channel change from a registration phase to free as a result of receiving a free channel presence signal with "registration phase terminated flag" set to 1.

The second randomization procedure (i.e. choosing an integer R randomly from the range DN206 to DN207) shall apply also for a non-immediate retransmission of DM-GSETUP by the DMCC.

If the channel is busy, or becomes busy, with a short transaction (e.g. an unsolicited registration or a registration cancellation), the DM-MS may choose to wait for the end of that transaction and then choose a new value of R instead of reporting to layer 3 that the call set-up message cannot be sent.

NOTE 1: Frequency efficient mode is not valid for transactions through a gateway.

NOTE 2: A DM-MS is permitted to implement a signal strength threshold where the DM-MS need not regard the channel as occupied or reserved by other users as a result of receiving DSBs below that threshold. However, if the received DSBs contain the gateway address of the gateway used by the DM-MS, the DM-MS should not try to make a call or registration to the gateway while the gateway is active.

8.4.2.2.4 DM-MS channel surveillance for registration outside the registration phase

A DM-MS may immediately begin registration procedures if the current perceived channel state is free and the DM-MS has been conducting the fast call set-up surveillance procedure described in clause 8.4.2.2.2.

If the DM-MS has not been conducting the fast call set-up surveillance procedure then, when the DM-MS wishes to make a registration request, it shall continuously monitor the DM RF carrier for a period of at least 8 frame durations. If the result of the channel surveillance indicates that the DM channel is free then the DM-MAC may begin sending the registration request signalling.

NOTE 1: If recent channel surveillance indicated that the channel was occupied or reserved then it is recommended that the DM-MS monitors for longer than 8 frame durations.

If the channel is free then the DM-MAC shall transmit the message using the procedures defined in clause 8.5.6.

If the DM-MS is currently receiving a multiple-frame free-channel presence signal then it should wait until the end of the repetitions of the presence signal. It may then transmit its registration request immediately (or optionally may choose to observe the channel for a random period before transmitting).

If the channel is not perceived as free, then the DM-MAC shall continue to monitor the channel:

- If the channel does not become free within a time DT234 then the DM-MAC shall report to layer 3, using the DMA-REPORT indication, that the message cannot be sent.
- If the DM-MAC observes the channel become free then it shall choose an integer R randomly from the range DN235 to DN236 (using a uniform distribution) and plan to start sending the message after R frame durations. It shall continue to monitor the channel during the intervening time and if it detects traffic or signalling activity then it shall either report to layer 3 that the message cannot be sent or use the option described in note 2.

For a retransmission of DM-GREGISTER REQUEST by the DMMM, the DM-MAC shall choose an integer R randomly from the range DN237 to DN238 (using a uniform distribution) and plan to start sending the message after R frame durations. However, during the intervening time, the DM-MS shall continuously monitor the DM RF carrier. If, during this time, it detects traffic or signalling activity then it shall either report to layer 3 that the message cannot be sent or use the option described in note 2.

In the above procedures, the DM-MS should not regard a free-channel presence signal as "traffic or signalling activity" causing the registration request to be abandoned. However, if the defined procedures would result in the DM-MS transmitting signalling during the transmission of a multiple-frame free-channel presence signal then the DM-MS shall wait until the end of the repetitions of the presence signal and then choose a new value of integer R randomly from the specified range and plan to start sending its message after R frame durations.

NOTE 2: If the channel has become busy with a short transaction (e.g. another DM-MS's unsolicited registration or a registration cancellation), the DM-MS may choose to wait for the end of that transaction and then choose a new value of R instead of reporting to layer 3 that the message cannot be sent.

8.4.2.3 Master DM-MS channel maintenance procedures during a call transaction

For a master DM-MS in circuit mode occupation for a call through a gateway: if it receives a DM-RESERVED message from the gateway, or a presence signal from the gateway indicating that the channel is reserved, then the master DM-MAC shall issue a DMC-REPORT indication to the higher layers reporting that the channel is now in reservation. (The DMCC then sends a DM-TX CEASED message, which the DM-MAC transmits before switching out of traffic mode.)

NOTE 1: For a call through a DM-REP/GATE, the DM-MS should perform this procedure if the DM-RESERVED message or reservation presence signal is received on either the master link or slave link.

For a master DM-MS in circuit mode occupation for a call through a DM-GATE: if it receives a presence signal from the gateway indicating that the channel is free, or if a time DT226 elapses without receipt of a DSB in timeslot 3 of frames 1, 7 or 13 containing a gateway presence signal indicating that the channel is occupied, then the master DM-MAC shall issue a DMC-REPORT indication to the higher layers reporting that the link to the gateway has failed. (The DMCC then sends a DM-RELEASE message, which the DM-MAC transmits before becoming idle).

For a master DM-MS in circuit mode occupation for a call through a DM-REP/GATE: if it receives a presence signal from the gateway (on either the master link or slave link) indicating that the channel is free, or if a time DT226 elapses without receipt of a DSB in timeslot 3 of master link frames 1, 7 or 13 containing:

- a random access request addressed to itself; or
- a gateway presence signal indicating that the channel is occupied;

then the master DM-MAC shall issue a DMC-REPORT indication to the higher layers reporting that the link to the gateway has failed. (The DMCC then sends a DM-RELEASE message, which the DM-MAC transmits before becoming idle).

NOTE 2: During circuit mode occupation, the master DM-MS monitors for a DSB in timeslot 3 of frames 1, 7 and 13 for link maintenance purposes, as defined above (i.e. timer DT226). It also uses DSBs received from the gateway to re-align its timing and frequency synchronization, as defined in clause 15.

8.4.2.4 Slave DM-MS channel maintenance procedures during a call

A slave DM-MS operating either in signalling or traffic mode on a DM channel may conduct the following or equivalent channel surveillance procedures.

8.4.2.4.1 Slave MS channel maintenance during call transaction

EN 300 396-3 [3], clause 8.4.2.4.1 shall apply.

8.4.2.4.2 Slave MS signal quality measurement during call transaction

EN 300 396-3 [3], clause 8.4.2.4.2 shall apply except that:

- for operation with a DM-GATE, the slave MS estimates the success rate of decoding the relevant signalling messages received from the current master in timeslot 3 of frames 6 and 12 and timeslot 1 or 3 of slave link frame 18;
- for operation with a DM-REP/GATE, the slave MS estimates the success rate of decoding the relevant signalling messages received in timeslot 3 of frames 6 and 12 and timeslot 1 or 3 of frame 18, on the slave link, or the master link in the case of a slave DM-MS monitoring the master link.

8.4.2.4.3 Slave MS channel maintenance during reservation

EN 300 396-3 [3], clause 8.4.2.4.3 shall apply.

8.4.3 Criteria for changing DM-MAC states

8.4.3.1 Criteria for changing DM-MAC state for master DM-MS

EN 300 396-3 [3], clause 8.4.3.1 shall apply with the following differences:

- i) A DM-MS does not ever acknowledge changeover requests during a call through a gateway nor does it ever send a message indicating end of channel reservation.
- ii) In criterion b), after accepting pre-emption of an ongoing call through a gateway the DM-MS shall use a reservation time remaining of 001111_2 (i.e. 5 multiframes).
- iii) Frequency efficiency mode is not applicable for a transaction through a gateway.

The DM-MAC shall also change the current state condition if one of the following occurs:

- the DM-MS receives a channel state change command from the gateway;
- the DM-MS receives a presence signal from the gateway used for the call or unsolicited registration, indicating a channel state change.

8.4.3.2 Criteria for changing DM-MAC state for slave DM-MS

EN 300 396-3 [3], clause 8.4.3.2 shall apply with the following differences:

- i) In criterion c), after receiving acceptance of a changeover or pre-emption within the ongoing call, other DM-MSs shall use a reservation time remaining of 001111_2 (i.e. 5 multiframes).
- ii) In criterion f) (i.e. "the DM-MS is in channel reservation, and a time corresponding to...") the remaining reservation time is also measured from a DM-GACK message with "reservation announced" element set to 1.

- iii) Criterion g) (i.e. "the DM-MS is in channel reservation after accepting a request for channel changeover or pre-emption...") is replaced by the more general criterion:
 - g) the DM-MS is in channel reservation after being master in the last circuit mode call transaction, and a time corresponding to the "reservation time remaining" element from its DM-TX CEASED messages has elapsed without receipt of channel reservation signalling from the gateway;
- iv) In criterion h) after receiving acceptance of changeover of pre-emption within the ongoing call through a gateway, sent to another DM-MS, the DM-MS shall use a reservation time of 5 multiframe durations since the end of the frame countdown for the acceptance message.
- v) Frequency efficiency mode is not applicable for a transaction through a gateway.

The DM-MAC shall also change the current state condition if one of the following occurs:

- the DM-MS is in channel reservation after sending short data as a transaction within a circuit mode call, and a time DT208 has elapsed since completion of the short data transaction (or a pre-emption acceptance) without receipt of channel reservation signalling from the gateway;
- the DM-MS is in channel reservation after receiving short data sent as a transaction within a circuit mode call, and a time DT208 has elapsed since expiry of the "SDS time remaining" without receipt of channel reservation signalling from the gateway;
- the DM-MS receives a channel state change command from the gateway;
- the DM-MS receives a presence signal from the gateway used for the call or solicited registration, indicating a channel state change;
- the DM-MS completes a registration request transaction;
- the DM-MS is in a registration phase and a time corresponding to the "registration phase time remaining" element from the last received REGISTRATION-phase gateway presence signal has elapsed since receipt of that message;
- the DM-MS is in a registration phase and it receives a DM-PRE ACCEPT message from the gateway;
- the DM-MS is in registration occupation and a time corresponding to the "registration transaction time remaining" element from the last received DM-GREGISTER CANCEL or unsolicited DM-GREGISTER REQUEST message has elapsed since receipt of that message.

NOTE: The "registration phase time remaining" and "registration transaction time remaining" are measured to the end of the appropriate frame. Where the time remaining element corresponds to a range of frames remaining, recipient DM-MSs should assume the highest value in that range.

8.4.3.3 Criteria for changing DM-MAC state for idle DM-MS

EN 300 396-3 [3], clause 8.4.3.3 shall apply with the following differences:

- i) In criterion f), after receiving acceptance of a changeover or pre-emption within an ongoing call through a gateway, other DM-MSs shall use a reservation time remaining of 001111_2 (i.e. 5 multiframe).
- ii) In criterion l) (i.e. "the DM-MS is idle in reservation, and a time corresponding to...") the remaining reservation time is also measured from a DM-GACK message with "reservation announced" element set to 1.
- iii) In criterion m) after receiving acceptance of changeover of pre-emption within an ongoing call through a gateway, the DM-MS shall use a reservation time of 5 multiframe durations since the end of the frame countdown for the acceptance message.

The DM-MAC shall also change the current state condition if one of the following occurs:

- the DM-MS is in channel reservation after receiving short data sent as a transaction within a circuit mode call, and a time DT208 has elapsed since expiry of the "SDS time remaining" without receipt of channel reservation signalling from the gateway;

- the DM-MS receives a gateway specific call set-up message (e.g. DM-GSETUP, DM-GACK with "reservation announced" element set to 1, or DM-GCONNECT);
- the DM-MS receives a gateway presence signal indicating that the channel is occupied or reserved or in a registration phase;
- the DM-MS receives a gateway presence signal indicating that the channel is free then:
 - if the channel is currently perceived as being occupied or reserved in a call through that gateway, or in a registration phase with that gateway as master, then the receiving DM-MS shall change the perceived DM channel state to free;
 - if the channel is currently perceived as being occupied or reserved in a call not involving that gateway, or in a registration phase with another gateway as master, then the receiving DM-MS shall not change the perceived DM channel state.
- the DM-MS starts a registration request transaction;
- the DM-MS is in a registration phase and a time corresponding to the "registration phase time remaining" element from the last received REGISTRATION-phase gateway presence signal has elapsed since receipt of that message;
- the DM-MS is in a registration phase and it receives a DM-PRE ACCEPT message from the gateway;
- the DM-MS is in registration occupation and a time corresponding to the "registration transaction time remaining" element from the last received DM-GREGISTER CANCEL or unsolicited DM-GREGISTER REQUEST message has elapsed since receipt of that message.

NOTE: The "registration phase time remaining" and "registration transaction time remaining" are measured to the end of the appropriate frame. Where the time remaining element corresponds to a range of frames remaining, recipient DM-MSs should assume the highest value in that range.

8.4.4 DM-MS channel monitoring procedures

A DM-MS in idle mode shall monitor the DM RF carrier in order to keep an up-to-date record of the perceived state of the channel and to receive any call set-up messages addressed to itself; see clause 8.4.2.2. The following clauses define the DM-MS monitoring requirements for operation with a gateway when the DM-MS is master or slave in a call or when it is attempting random access.

If the protocol requires the DM-MS to transmit in any of the monitoring slots specified in this clause, the transmission takes precedence over the monitoring requirement.

NOTE: For operation with a DM-GATE or type 1A DM-REP/GATE, the DM-MS performs the channel monitoring procedures on the selected DM RF carrier. For operation with a type 1B DM-REP/GATE, the DM-MS performs the channel monitoring procedures on the selected DM downlink RF carrier f_2 , except in the case that the DM-MS is monitoring the master link in which case it performs the channel monitoring procedures on the selected DM uplink RF carrier f_1 .

8.4.4.1 DM channel when setting up a circuit mode call through a gateway

After transmission of DM-GSETUP messages, a calling DM-MS shall monitor timeslots 1 and 3 throughout the call set-up period (or until layer 3 indicates "call release"), except for timeslot 3 of linearization frames. It shall look for DSBs from the gateway.

NOTE 1: This monitoring requirement applies both when waiting for a first response from the gateway and when waiting for a further response after receiving DM-GACK. It also applies during the frame countdown for the DM-GACK (since the gateway may cut short the retransmissions of the DM-GACK in order to send DM-GCONNECT).

NOTE 2: The DM-MS is a slave during call set-up through a gateway. Therefore, for operation through a DM-REP/GATE, this monitoring requirement refers to slots on the slave link.

8.4.4.2 DM channel when receiving a circuit mode call set-up from a gateway

For a circuit mode call set-up with presence check, after transmission of DM-CONNECT messages, the called DM-MS shall monitor timeslots 1 and 3 throughout the call set-up period (or until layer 3 indicates "call release"), except for timeslot 3 of linearization frames. It shall look for DSBs from the gateway.

NOTE: The DM-MS is a slave when receiving a call set-up. Therefore, for a call from a DM-REP/GATE, this monitoring requirement refers to slots on the slave link.

8.4.4.3 DM channel in occupation during a circuit mode call

A master MS during an active call transaction through a DM-GATE shall monitor:

- timeslot 3 of frames 2, 5, 8, 11, 14 and 17 for a DSB containing pre-emption signalling (or a DM-GRELEASE message); and
- timeslot 3 of frames 1, 7 and 13 for a DSB generated by the DM-GATE; the DSB may contain a gateway presence signal, a pre-emption request from the gateway or a DM-GRELEASE message.

A master MS during an active call transaction through a DM-REP/GATE shall monitor timeslot 3 of frames 1, 4, 7, 10, 13 and 16 on the master link for a DSB containing pre-emption signalling sent from a slave MS via the DM-REP/GATE, or for a DSB generated by the DM-REP/GATE.

NOTE: The master MS is not required to monitor timeslot 3 during the transmission of the DM-TX CEASED message at the end of circuit mode occupation.

A slave MS during channel occupation should monitor and attempt to decode the DNB transmitted in timeslot 1 of frames 1 to 17 (see clause 8.6.2).

A slave MS during channel occupation shall monitor and attempt to decode the DSB containing occupation or other signalling in timeslot 3 of frames 6, 12 and 18. For operation with a DM-REP/GATE, this monitoring requirement refers to slots on the slave link, or the master link in the case of a slave DM-MS monitoring the master link.

8.4.4.4 DM channel in reservation during a circuit mode call

A slave MS during channel reservation shall monitor and attempt to decode a DSB in timeslots 1 and 3 at least every two frames. Monitoring of timeslot 3 of frame 3 does not contribute to fulfilling this requirement. The monitoring shall include timeslots 1 and 3 of frames 6, 12 and 18 in each multiframe.

NOTE 1: This monitoring is needed, for example, so that the slave MS can receive reservation signalling and so that it can determine when a new call transaction has begun or detect a timing change announcement or new call pre-emption acceptance or call release. The monitoring of timeslots 1 and 3 is in case the gateway redefines the slot and/or frame numbering.

A slave MS wishing to become the new master on the channel shall, following the transmission of the transmit request message (DM-GTX REQUEST or DM-TX REQUEST), monitor timeslots 1 and 3 in the following frames (except timeslot 3 of linearization frames, or when sending a retransmission) for a DSB from the gateway indicating the result of the request. For a DM-GTX REQUEST message, this monitoring requirement applies both when waiting for a first response from the gateway and when waiting for a further response after receiving DM-GACK (and during the frame countdown for the DM-GACK).

NOTE 2: For operation with a DM-REP/GATE, these monitoring requirements refer to slots on the slave link.

8.4.4.5 DM channel in occupation during an SDS call

During SDS transmissions sent through a DM-GATE, the master MS shall monitor timeslot 3 of frames 2, 5, 8, 11, 14 and 17 for a DSB carrying pre-emption request signalling (or a DM-GRELEASE message). It shall also monitor timeslot 3 of frames 1, 7 and 13 for a DSB generated by the DM-GATE; the DSB may contain a gateway presence signal, a pre-emption request from the gateway or a DM-GRELEASE message.

During SDS transmissions sent through a DM-REP/GATE, the master MS shall monitor timeslot 3 of frames 1, 4, 7, 10, 13 and 16 on the master link for a DSB containing pre-emption signalling sent from a slave MS via the DM-REP/GATE, or for a DSB generated by the DM-REP/GATE.

NOTE 1: When sending short data through a DM-REP/GATE, the master DM-MS may choose to monitor the slave link in order to detect successful re-transmissions on the slave link. This may be found useful for unacknowledged short data messages.

For SDS transmissions that require an acknowledgement, the master MS shall monitor timeslots 1 and 3 in those frames assigned for acknowledgement messages from the gateway. It should start looking for the acknowledgement message in the frame immediately following the end of the SDS transmission. For operation with a DM-REP/GATE, this monitoring requirement refers to slots on the master link.

When receiving a fragmented SDS message from a gateway, a slave MS shall monitor timeslot 1 of frames 1 to 17 for DNBs containing continuation fragments, as specified in clauses 8.5.4.2 and 8.5.6.2.

A slave MS during SDS occupation shall monitor and attempt to decode the DSB containing occupation or other information transmitted in timeslot 3 of frames 6, 12 and 18.

Also, after receiving an unacknowledged SDS message or responding to an acknowledged SDS message, a slave MS during SDS occupation shall monitor and attempt to decode a DSB in timeslot 1 or 3 (or both) at least every two frames.

NOTE 2: This monitoring applies until the SDS time remaining expires or the MS detects the start of a retransmission or a new call pre-emption acceptance (or a reservation message in the case of short data sent as a transaction within an ongoing call).

NOTE 3: The DM channel during SDS is always in occupation (i.e. not reservation), even during periods where acknowledgement messages are to be sent.

8.4.4.6 DM channel during pre-emption signalling

A DM-MS following the transmission of a request to pre-empt the channel (DM-GPREEMPT or DM-PREEMPT message) shall monitor timeslots 1 and 3 in the following frames (except timeslot 3 of linearization frames, or when sending a retransmission) to determine the result of the pre-emption request. The response to the pre-emption request may be sent by the master using either a DSB or a DNB with slot flag set; refer to clause 8.5.7. For a DM-GPREEMPT message, this monitoring requirement applies both when waiting for a first response from the gateway and when waiting for a further response after receiving DM-GACK (and during the frame countdown for the DM-GACK).

A slave DM-MS pre-empting a DM-MS during circuit mode occupation in order to continue the ongoing call shall, following receipt of a DM-PRE ACCEPT message, send DM-GTX REQUEST messages to the gateway in at least two frames. Following the transmission of these messages, the DM-MS shall monitor timeslots 1 and 3 in the following frames (except timeslot 3 of linearization frames, or when sending a retransmission) for a DSB from the gateway indicating the result of the request. This monitoring requirement applies both when waiting for a first response from the gateway and when waiting for a further response after receiving DM-GACK (and during the frame countdown for the DM-GACK).

NOTE: For operation with a DM-REP/GATE, these monitoring requirements refer to slots on the slave link, or the master link in the case of an idle DM-MS pre-empting for new call on the master link.

8.4.4.7 DM channel during registration phase

A slave MS during a registration phase shall monitor timeslot 3 at least every two frames, for a DSB containing the gateway presence signal, where monitoring of timeslot 3 of frame 3 does not contribute to fulfilling this requirement.

A slave DM-MS shall, following transmission of a solicited registration request during a registration phase, monitor timeslot 1 of the following frames for a DSB indicating the result of the registration request.

NOTE: For operation with a DM-REP/GATE, these monitoring requirements refer to slots on the slave link.

8.4.4.8 DM channel in occupation for an unsolicited registration

After transmission of unsolicited registration messages, the master MS shall monitor timeslots 1 and 3 in those frames assigned for acknowledgement messages from the gateway.

NOTE: For operation with a DM-REP/GATE, this monitoring requirement refers to slots on the master link.

8.4.5 Transmission of layer 3 messages by DM-MAC

NOTE: For operation with a DM-GATE or type 1A DM-REP/GATE, the DM-MS transmits on the selected DM RF carrier. For operation with a type 1B DM-REP/GATE, the DM-MS transmits on the DM uplink RF carrier f_1 .

8.4.5.1 Transmission of C-plane messages by DM-MAC

8.4.5.1.1 Transmitting DM-SETUP

EN 300 396-3 [3], clause 8.4.5.1.1 shall apply with the following differences:

- i) DM-SETUP is not sent by DM-MSs on a free channel. It is only ever sent after receipt of a DM-GCONNECT message from the gateway or after a pre-emption or changeover. Therefore the DM-MAC does not need to monitor to check whether the current state of the DM channel is free before it sends the DM-SETUP messages.
- ii) When the DM-MS is sending DM-SETUP for a new group call through a DM-GATE (i.e. for the first transaction in a group call through a DM-GATE), it shall send the DM-SETUP message in at least two frames. Otherwise (i.e. for an individual call through a DM-GATE, for a call through a DM-REP/GATE or for a call continuation), the DM-MS shall send the DM-SETUP message in at least one frame. The requirement to send the DM-SETUP message in at least three frames if the transmission includes frame 3 does not apply.
- iii) Whenever the DM-MS is sending a DM-SETUP message, it shall transmit the DSB in all four timeslots in each of the signalling frames except that, when operating with a DM-REP/GATE, timeslot 4 of the final signalling frame shall not be used.

8.4.5.1.2 Transmitting DM-SETUP PRES

The DM-SETUP PRES message is not sent by DM-MSs when operating with a gateway.

8.4.5.1.3 Transmitting DM-CONNECT

EN 300 396-3 [3], clause 8.4.5.1.3 shall apply.

The DM-MS should also transmit the DM-CONNECT message in timeslot 2 in each of the signalling frames (unless, for the first signalling frame, it is using that timeslot for linearization) and in timeslot 4 in each of the signalling frames, except that timeslot 4 of the final signalling frame shall not be used.

NOTE: The transmission of the DM-CONNECT message is timed relative to the DM-SETUP PRES message received from the gateway.

8.4.5.1.4 Transmitting DM-DISCONNECT

EN 300 396-3 [3], clause 8.4.5.1.4 shall apply.

The DM-MS should also transmit the DM-DISCONNECT message in timeslot 2 in each of the signalling frames (unless, for the first signalling frame, it is using that timeslot for linearization) and in timeslot 4 in each of the signalling frames, except that timeslot 4 of the final signalling frame shall not be used.

NOTE: The transmission of the DM-DISCONNECT message is timed relative to the DM-SETUP PRES message received from the gateway.

8.4.5.1.5 Transmitting DM-CONNECT ACK

The DM-CONNECT ACK message is not sent by DM-MSs when operating with a gateway.

8.4.5.1.6 Transmitting DM-RELEASE

EN 300 396-3 [3], clause 8.4.5.1.6 shall apply with the following differences:

- i) A DM-MS is never master during channel reservation.
- ii) The requirement to send an independent DM-RELEASE message in at least three frames if the transmission includes frame 3 does not apply.

8.4.5.1.7 Transmitting DM-OCCUPIED

EN 300 396-3 [3], clause 8.4.5.1.7 shall apply with the following differences:

- i) At the end of channel occupation, the DM-MS becomes a slave after transmitting the requisite number of DM-TX CEASED messages and therefore does not send DM-RESERVED messages.
- ii) The option to send DM-OCCUPIED in timeslots 2 and/or 4 does not apply for operation with a type 1A DM-REP/GATE.
- iii) Channel B operation is not valid for a call through a gateway.

8.4.5.1.8 Transmitting DM-TX CEASED

EN 300 396-3 [3], clause 8.4.5.1.8 shall apply with the following differences:

- i) When sending DM-TX CEASED in timeslot 1 of a frame, a DM-MS shall send the message also in timeslot 3 of that frame – unless it is sending DM-PRE ACCEPT or this is a linearization frame.
- ii) If the master MS is terminating its traffic transmission because it is accepting a pre-emption request then it shall set the "reservation time remaining" element to 001111₂ (i.e. 5 multiframe) in the DM-TX CEASED messages.
- iii) If the master MS is terminating its traffic transmission because it has received a presence signal from the gateway indicating that the channel is reserved then it shall set the "reservation time remaining" element to 001111₂ (i.e. 5 multiframe) in the DM-TX CEASED messages.
- iv) If the master MS is terminating its traffic transmission because it has received a DM-RESERVED message from the gateway then it shall set the "reservation time remaining" element in the DM-TX CEASED messages to the value from the DM-RESERVED message.
- v) If the master MS is terminating its traffic transmission for the normal case of the master ceasing transmission then it shall set the "reservation time remaining" element to 001111₂ (i.e. 5 multiframe) in the DM-TX CEASED messages.
- vi) The requirement to send a DM-TX CEASED message announcing a timing change in at least three frames if the transmission includes frame 3 does not apply.

8.4.5.1.9 Transmitting DM-TX REQUEST

EN 300 396-3 [3], clause 8.4.5.1.9 shall apply.

NOTE: The DM-TX REQUEST message is used only for requesting changeover in order to send short data as a transaction within a circuit mode call.

8.4.5.1.10 Transmitting response to DM-TX REQUEST

The gateway is always master during channel reservation. Therefore DM-MSs do not invite or respond to DM-TX REQUEST messages.

8.4.5.1.11 Transmitting DM-PREEMPT

EN 300 396-3 [3], clause 8.4.5.1.11 shall apply (for pre-emption of either a DM-MS or the gateway).

The DM-PREEMPT message may also be sent (using a DSB) during a registration phase in timeslot 3 of any frame except frames 3, 6, 12 or 18; refer to clause 8.5.8.2. If the MS does not receive an acknowledgement within a prescribed time then it may retransmit the pre-emption request using the procedure detailed in clause 8.5.8.2.5.

8.4.5.1.12 Transmitting response to DM-PREEMPT

EN 300 396-3 [3], clause 8.4.5.1.12 shall apply with the following differences:

- i) A DM-MS is never master during reservation.
- ii) The requirements to send a DM-PRE ACCEPT message announcing a timing change or accepting pre-emption by a late entering gateway in at least three frames if the transmission includes frame 3 do not apply.

8.4.5.1.13 Transmitting DM-SDS UDATA and DM-SDS DATA

EN 300 396-3 [3], clause 8.4.5.1.13 shall apply with the following differences:

- i) When sending a non-fragmented DM-SDS DATA message on a free channel, the SDS call set-up DSB shall be sent in at least timeslots 1 and 3 of frames FN and FN + 1 up to a maximum of FN + 3, where FN is the current or initial value of the DM-MS frame counter.
- ii) When sending DM-SDS UDATA or DM-SDS DATA after a successful changeover or pre-emption procedure, the SDS set-up DSB shall be sent in at least timeslots 1 and 3 of frame FN and up to a maximum of FN + 3, where FN is the current value of the DM-MS frame counter.
- iii) Whenever the DM-MS is sending a DM-SDS UDATA or DM-SDS DATA message starting with DSBs, it shall transmit the DSB in all four timeslots in each of the signalling frames except that, when operating with a DM-REP/GATE or when sending a non-fragmented DM-SDS DATA message through a DM-GATE, timeslot 4 of the final signalling frame shall not be used.

NOTE: This difference does not apply when the DM-MS is sending DM-SDS UDATA during circuit mode occupation.

- iv) Following the transmission of the DSBs for a fragmented DM-SDS UDATA or DM-SDS DATA message, sent through a DM-REP/GATE, the timing of the next fragment shall be as defined in clause 8.5.4.1.
- v) A DM-MS is never master during reservation.
- vi) The requirements to send an SDS set-up DSB in at least three frames if the transmission includes frame 3 do not apply.

8.4.5.1.14 Transmitting response to DM-SDS DATA

EN 300 396-3 [3], clause 8.4.5.1.14 shall apply.

The DM-MS should also transmit the response DSB in timeslot 2 in each of the DSB signalling frames (unless, for the first DSB signalling frame, it is using that timeslot for linearization) and in timeslot 4 in each of the DSB signalling frames – except in the case of a DM-REJECT or non-fragmented DM-SDS ACK for which timeslot 4 of the final DSB signalling frame shall not be used.

NOTE: The transmission of a DM-SDS ACK or DM-REJECT message is timed relative to the DM-SDS DATA message received from the gateway.

8.4.5.1.15 Transmitting DM-INFO

EN 300 396-3 [3], clause 8.4.5.1.15 shall apply.

8.4.5.1.16 Transmitting DM-GSETUP

DMA-UNITDATA request message type: DM-GSETUP

Channel condition: Channel free – MS idle

DM-MAC PDU type: DMAC-SYNC, END

A DM-MS which is currently in idle mode shall, having determined that the current state of DM channel is free, send the DM-GSETUP message (as a slave DM-MS) using a DSB. The DM-GSETUP message shall be sent in timeslots 1 and 3 of frames FN and FN+1 up to a maximum of FN+3, where FN is the current or initial value of the frame counter. The number of frames in which the message is sent shall be indicated by the frame countdown element value.

The DM-MS shall also send the DM-GSETUP messages in timeslots 2 and 4 in each of the signalling frames except that, for a non-fragmented DM-GSETUP, timeslot 4 of the final signalling frame shall not be used.

A DM-GSETUP may be fragmented, with one fragment following the DMAC-SYNC PDUs. The final fragment (DMAC-END PDU) shall be sent once, in a timeslot 1, using a DNB, see clause 8.5.4.1.

DM-GSETUP may also be sent after a pre-emption for a new call. Then the above procedure applies for the transmission of the DM-GSETUP, except that the DM-MS need not check that the DM channel is free.

8.4.5.1.17 Transmitting DM-GTX REQUEST

DMA-UNITDATA request message type: DM-GTX REQUEST

Channel condition: Channel reserved – MS slave

DM-MAC PDU type: DMAC-SYNC

A slave MS shall using the procedure described in clause 8.5.7.3, having received a DM-RESERVED message, send a DM-GTX REQUEST message using a DSB in timeslot 3 in one of the pre-emption frames or one of those frames indicated by the "requests bitmap" sent by the gateway. If the slave MS is unsuccessful it may retransmit the transmit request using the procedure detailed in clause 8.5.7.3.5 of [3].

DMA-UNITDATA request message type: DM-GTX REQUEST

Channel condition: MS has pre-empted another DM-MS

DM-MAC PDU type: DMAC-SYNC

A DM-MS having successfully pre-empted another DM-MS during channel occupation in order to continue the ongoing call shall send the DM-GTX REQUEST message (as a slave DM-MS) using a DSB. The DM-GTX REQUEST message shall be sent in timeslots 1 and 3 of frames FN and FN+1 up to a maximum of FN+3, where FN is the current value of the frame counter. The number of frames in which the message is sent shall be indicated by the frame countdown element value.

The DM-MS shall also send the DM-GTX REQUEST messages in timeslots 2 and 4 in each of the signalling frames except the final signalling frame where timeslot 4 shall not be used.

After sending the DM-GTX REQUEST using this mechanism, the DM-MS shall revert to obeying the random access procedure described in clause 8.5.7.3 e.g. looking for a response DM-GACK, DM-GTX ACCEPT or DM-GREJECT from the gateway. For timing and counting purposes in clause 8.5.7.3, the DM-MAC shall regard the multiple transmission as if it had been a single random access transmission in slot 3 of the final signalling frame (i.e. the frame with "frame countdown" element set to 00₂).

NOTE: So, for example, the DM-MAC looks for a response in slot 1 and slot 3 of the following frames. If a response is not received within a time DT211 after the final transmission of the DM-GTX REQUEST then the DM-MAC assumes that the multiple transmission has failed and selects an access slot randomly for a retry, regarding that retry as the second transmission of the request (so $M = 2 - 1 = 1$). It then continues to obey the procedures in clause 8.5.7.3.

When the DM-GTX REQUEST message is sent following successful pre-emption of a DM-MS, the "type of DM-GTX REQUEST" element is set to 1 for all transmissions i.e. it is set to 1 for the transmissions sent using the special transmission method in multiple frames and also in any further DM-GTX REQUEST messages sent using the random access protocol.

8.4.5.1.18 Transmitting DM-GPREEMPT

DMA-UNITDATA request message type: DM-GPREEMPT

Channel condition: Channel occupied by gateway – MS slave

Channel reserved – MS slave

DM-MAC PDU type: DMAC-SYNC

A slave MS shall using the procedure described in clause 8.5.7.3 send a DM-GPREEMPT message using a DSB in timeslot 3 of either frames 2, 5, 8, 11, 14 or 17 of a multiframe. A slave MS which does not receive an acknowledgement within a prescribed time may retransmit the pre-emption request using the procedure detailed in clause 8.5.7.3.5 of [3].

NOTE 1: During channel reservation DM-GPREEMPT requests may also be sent in timeslot 3 of other frames indicated by the "requests bitmap".

NOTE 2: The DMCC uses DM-GPREEMPT only if the gateway is master of the channel and the request is for a continuation of the ongoing call. It uses the normal DM-PREEMPT message for pre-emption of a DM-MS, or for pre-emption for a new call.

8.4.5.1.19 Transmitting DM-GREGISTER REQUEST

NOTE: The DM-MS is a slave when sending message DM-GREGISTER REQUEST during a registration phase and so, for operation with a DM-REP/GATE, references below to slot and frame numbers refer to the numbering on the slave link.

However, the DM-MS is master when sending message DM-GREGISTER REQUEST on a free channel and so, for operation with a DM-REP/GATE, references below to slot and frame numbers refer to the numbering on the master link. (Note that the method for sending message DM-GREGISTER REQUEST on a free channel is similar to the method for sending a non-fragmented DM-SDS DATA message on a free channel).

DMA-UNITDATA request message type: DM-GREGISTER REQUEST

Channel condition: Channel in registration phase – MS slave

DM-MAC PDU type: DMAC-SYNC

An MS shall, using the procedure described in clause 8.5.8.1, send a DM-GREGISTER REQUEST message as a slave using a DSB in timeslot 3 of one of the valid frames as defined in clause 8.5.8.1.3. If the slave MS is unsuccessful it may retransmit the registration request using the procedure detailed in clause 8.5.8.1.5.

DMA-UNITDATA request message type: DM-GREGISTER REQUEST

Channel condition: Channel free – MS idle

DM-MAC PDU type: DMAC-SYNC

A DM-MS which is currently in idle mode shall, having determined that the current state of DM channel is free, send the DM-GREGISTER REQUEST message as a master using a DSB. The DM-GREGISTER REQUEST message shall be sent in timeslots 1 and 3 of frames FN and FN+1 up to a maximum of FN+3, where FN is the current or initial value of the frame counter. The number of frames in which the message is sent shall be indicated by the frame countdown element value.

A DM-MS shall also send the DM-GREGISTER REQUEST message in timeslots 2 and 4 in each of the signalling frames except the final signalling frame where timeslot 4 shall not be used.

8.4.5.1.20 Transmitting DM-GCANCEL ACK

DMA-UNITDATA request message type: DM-GCANCEL ACK

Channel condition: Channel occupied – MS slave

DM-MAC PDU type: DMAC-SYNC

A DM-MS, having received a DM-GREGISTER CANCEL message from a gateway shall send a DM-GCANCEL ACK message in timeslots 1 and/or 3 using a DSB in those frames indicated by the gateway; see clause 8.5.6.2. The number of frames in which the DSB is sent shall be indicated by the frame countdown element.

The DM-MS should also transmit the DM-GCANCEL ACK message in timeslot 2 in each of the signalling frames (unless, for the first signalling frame, it is using that timeslot for linearization) and in timeslot 4 in each of the signalling frames, except that timeslot 4 of the final signalling frame shall not be used.

8.4.5.2 Transmission of U-plane messages by DM-MAC

During channel occupation, a master DM-MAC on receiving a DMD-UNITDATA request from the U-plane application shall perform the procedures as defined in clause 8.6.4.

8.4.6 Transmission of layer 2 messages generated by DM-MAC

8.4.6.1 Transmitting DM-RESERVED

The DM-RESERVED message is not sent by DM-MSs when operating with a gateway.

8.4.6.2 Transmitting DM-SDS OCCUPIED

EN 300 396-3 [3], clause 8.4.6.2 shall apply with the following differences:

- i) The option to send DM-SDS OCCUPIED in timeslots 2 and / or 4 does not apply for operation with a type 1A DM-REP/GATE.
- ii) Channel B operation is not valid.

Also, following the transmission of short data sent as a transaction within a circuit mode call, the master DM-MS shall send DM-SDS OCCUPIED messages in timeslots 1 and 3 of at least two frames. These DM-SDS OCCUPIED messages shall all contain element "SDS time remaining" set to 0000₂, with the "frame countdown" element used to indicate when the transmissions are complete (and the "SDS transaction type" element still set to 1). After these transmissions, the DM-MS shall become a slave.

NOTE: These DM-SDS OCCUPIED messages indicate to the gateway that the DM-MS's short data transaction has finished and that the gateway should take up the master function for the subsequent reservation period. In this respect, they perform a similar function to DM-TX CEASED messages for a circuit mode transmission.

8.4.6.3 Transmitting DM-TIMING REQUEST

The DM-TIMING REQUEST message is not used for operation with a gateway.

8.4.6.4 Transmitting DM-TIMING ACK

The DM-TIMING ACK message is not sent by DM-MSs when operating with a gateway.

8.4.7 General DM-MAC procedures

8.4.7.1 DM-MAC repeat transmissions

EN 300 396-3 [3], clause 8.4.7.1 shall apply. The minimum and maximum numbers of transmission frames for messages sent using the frame countdown mechanism are given in annex A.

8.4.7.2 DM-MAC frame countdown procedure

EN 300 396-3 [3], clause 8.4.7.2 shall apply.

8.4.7.3 Use of timers

The DM-MAC shall use a set of timers e.g. to determine how long it should wait for a response to a signalling message. The timers are listed in annex A.

8.4.7.4 Linearization

A DM-MS wishing to begin a call may, after determining that the selected channel is free, linearize its transmitter in the time just prior to sending the call set-up signalling.

NOTE 1: A DM-MS is not permitted to linearize on a free channel at other times, unless it can linearize without transmitting on the channel.

During circuit mode occupation, a master MS may linearize in timeslot 3 of frame 3 of any multiframe. (For operation with a DM-REP/GATE, this refers to slots on the master link).

During circuit mode occupation, a slave MS (or idle MS) may only conduct linearization in frame 3 if permitted by the current master. (For operation with a DM-REP/GATE, this refers to slave link frame 3).

NOTE 2: If linearization is permitted during circuit mode occupation then it may be performed in timeslot 3 of frame 3 after the completion of the frame countdown for the transmissions of the DM-SETUP or DM-CONNECT ACK message.

The DM-MAC in the master MS shall permit the use of timeslot 3 of frame 3 for linearization, by setting the "LCH in frame 3 flag" equal to 1 when it sends the call set-up and occupation signalling.

NOTE 3: The requirement on the master to permit linearization during circuit mode occupation may be relaxed for some types of call in future editions of the present document. Therefore, recipients have to check the setting of the "LCH in frame 3 flag".

During circuit mode occupation in a via DM-REP/GATE call, an idle MS that is unable to receive on the slave link may conduct linearization in timeslot 3 of frame 3 of the master link.

During reservation, a slave MS (or idle MS) may conduct linearization in timeslot 3 of frame 3 of any multiframe. (For operation with a DM-REP/GATE, this refers to slots on the slave link).

NOTE 4: Any DM-MS may conduct linearization in timeslot 3 of frame 3 of any multiframe during reservation. This applies for reservation periods while a DM-MS is setting up a call through the gateway, and while the gateway is setting up a call with presence check to a DM-MS, in addition to the reservation periods after call transactions.

During short data occupation, a master MS may conduct linearization in timeslot 3 of frame 3 if timeslot 1 of frame 3 is an SCH/F slot. (For operation with a DM-REP/GATE, this refers to slots on the master link).

During short data occupation, a slave MS (or idle MS) may conduct linearization in timeslot 3 of frame 3 if timeslot 1 of frame 3 is an SCH/F slot (as indicated by the "number of SCH/F slots" element in the SDS call set-up DSBs), except that the following differences apply for operation with a DM-REP/GATE if the short data message was originated by a DM-MS (i.e. with "gateway generated message flag" set to 0):

- the MS may conduct linearization in timeslot 3 of slave link frame 3 if timeslot 1 of slave link frame 4 will be an SCH/F slot;

- for a DM-SDS UDATA message, the MS shall not conduct linearization in the slave link frame containing the final SCH/F slot.

During short data occupation during operation with a DM-REP/GATE, an idle MS that is unable to receive on the slave link may conduct linearization in timeslot 3 of master link frame 3 if timeslot 1 of frame 3 is an SCH/F slot (as indicated by the "number of SCH/F slots" element in the SDS call set-up DSBs).

When a called MS sends a response to a non-fragmented message from the gateway (received in frame X and containing "frame countdown" element F), the called MS may linearize its transmitter in timeslot 1 of frame $(X+F) \bmod 18 + 1$. When a called MS sends a response to a fragmented message, the called MS may linearize its transmitter in timeslot 1 of the frame following the frame that contained the DMAC-END PDU. (For operation with a DM-REP/GATE, this refers to slots on the slave link).

When a called MS sends a response to a non-fragmented message from the gateway, and if the gateway's message was received only in timeslot 4 of the frame containing "frame countdown" element set to 0, then the called MS may linearize its transmitter in timeslot 2 of the next frame (before transmission in timeslot 3). For operation with a DM-REP/GATE, this refers to slots on the slave link.

During a registration phase, any MS may conduct linearization in timeslot 3 of frame 3 of any multiframe. (For operation with a DM-REP/GATE, this refers to slots on the slave link.)

During a registration phase, if the DM-MS needs to transmit a request message before a normal linearization opportunity has occurred (i.e. a timeslot 3 of frame 3) then the DM-MS may conduct linearization in the timeslot 2 immediately preceding its request slot.

NOTE 5: For operation with a DM-GATE or type 1A DM-REP/GATE, the DM-MS linearizes on the selected DM RF carrier. For operation with a type 1B DM-REP/GATE, the DM-MS linearizes on the slave link on DM uplink RF carrier f_1 or on the master link on the downlink RF carrier f_2 .

8.4.7.5 Fragmentation

EN 300 396-3 [3], clause 8.4.7.5 shall apply.

8.4.7.6 Fill bit indication

EN 300 396-3 [3], clause 8.4.7.6 shall apply.

8.4.7.7 Selection of pseudo address

EN 300 396-3 [3], clause 8.4.7.7 shall apply.

8.4.7.8 Slot flag indication

EN 300 396-3 [3], clause 8.4.7.8 shall apply.

8.4.7.9 Requests bitmap

The gateway is always master of the channel during reservation periods. Therefore the DM-MS does not send the DM-RESERVED message and is not responsible for defining the "requests bitmap".

8.4.7.10 Dual watch operation

The present document does not support dual watch operation by a DM-MS operating with a gateway.

NOTE: The normal dual watch synchronization timing is not compatible with the DM channel timing likely to be used for calls through a gateway.

8.4.7.11 Air interface encryption

EN 300 396-3 [3], clause 8.4.7.11 shall apply.

8.4.7.12 Channel A or B operation

When the DM-MAC sends a DMAC-SYNC PDU, it shall set the "A/B channel usage" element to indicate "channel A, normal mode".

The DM-MAC shall not attempt to use channel A in normal mode while a frequency efficient mode call is ongoing and shall not attempt to pre-empt an ongoing frequency efficient mode call.

8.4.7.13 Sending short data as a transaction within a circuit mode call

EN 300 396-3 [3], clause 8.4.7.13 shall apply except that, after completion of the short data transaction, instead of sending DM-RESERVED messages, the MS shall send DM-SDS OCCUPIED messages with element "SDS time remaining" set to 0000₂ in slot 1 and slot 3 of at least two frames (as defined in clause 8.4.6.2) and shall then become a slave during the following reservation period.

A master MS, and also slave and idle MSs, shall enter reservation at the end of the occupation period for short data sent as a transaction within a circuit mode call (timing out of reservation if DM-RESERVED messages are not received from the gateway within a time DT208 – see clause 8.4.3.2).

8.4.7.14 SDS and registration transaction time remaining

8.4.7.14.1 SDS time remaining

EN 300 396-3 [3], clause 8.4.7.14 shall apply except that, when a DM-MS sends short data as a transaction within a circuit mode call, the additional frames included in the "SDS time remaining" element are to allow for transmission of DM-SDS OCCUPIED messages, not DM-RESERVED.

When operating with a DM-REP/GATE, the DM-MS shall include an allowance of DN233 frames within the SDS time remaining for the re-transmission of the short data DSBs on the slave link. This applies also to the registration transaction time remaining.

8.4.7.14.2 Registration transaction time remaining

Unsolicited DM-GREGISTER REQUEST messages shall contain the "registration transaction time remaining" element indicating the DM-MS's current estimate of how much longer the channel will remain in registration occupation, measured from the end of the frame in which the element is sent. It shall indicate the time for the current transmission and for the expected acknowledgement messages.

For a solicited DM-GREGISTER REQUEST message, the "registration transaction time remaining" element shall be set to 0000₂ (null value).

8.4.7.15 Timing change procedure

During a call through a gateway, DM-MSs shall not request a timing adjustment. Therefore the procedures defined in EN 300 396-3 [3], clause 8.4.7.15 do not apply.

8.4.7.16 Timing change at changeover or pre-emption

During a call through a gateway, a DM-MS requesting changeover or pre-emption within the ongoing call shall not include a "timing adjustment" element within the request message.

The gateway may include the "timing adjustment" element within a pre-emption message. Then, when the master DM-MS sends the DM-PRE ACCEPT messages (and DM-TX CEASED if appropriate), it shall announce the timing change to the other DM-MSs on the channel; see clause 8.4.7.18.

Also, a DM-MS requesting pre-emption for a new call may include the "timing adjustment" element within the pre-emption message (for example, if it intends to use direct MS-MS operation). Then, when the master DM-MS sends the DM-PRE ACCEPT messages, it shall announce the timing change to the other DM-MSs on the channel.

8.4.7.17 Modification of slot/frame numbering by gateway

When sending call set-up signalling or during reservation periods (either during call set-up through a gateway or after a call transaction), the gateway may redefine the slot and/or frame numbering. It does so simply by setting the "slot number" and "frame number" elements appropriately in the DMAC-SYNC PDU, without a prior announcement. On receipt of a DMAC-SYNC PDU from the gateway containing new slot or frame numbering counters, the MAC in the DM-MS shall adopt those new counters.

8.4.7.18 Modification of channel timing by gateway

During reservation periods (either during call set-up through a gateway or after a call transaction), the gateway may announce a channel timing change by including the "timing adjustment" element in DM-GACK or DM-TIMING ACK messages; see clause 13.4.7.16.

If the gateway is transmitting circuit mode traffic then it may announce a channel timing change by sending DM-TX CEASED messages including the "timing adjustment" element.

The gateway may pre-empt a DM-MS's circuit mode transmission requesting a timing change, in which case the DM-MS shall include the "timing adjustment" element when it sends the DM-PRE ACCEPT messages (and DM-TX CEASED if appropriate).

In all these cases the gateway then transmits DSBs using the new timing reference in timeslots 1 and 3 of the next two frames, with the "frame countdown" element used to indicate when the transmissions of the DSB are complete. All channel signalling from DM-MSs shall use the new timing reference following reception of a DSB from the gateway.

NOTE: The size of the announced timing adjustment is given with a resolution of only 0,5 ms, whereas the gateway normally requires the DM channel timing to be tightly linked to the TMO timing. The gateway's DSBs will define the precise timing. Therefore, when looking for DSBs using the new timing reference, the DM-MS should look within a window on either side of the announced value of the timing change.

8.5 MAC procedures for transfer of signalling messages

8.5.1 Formation of MAC PDU

EN 300 396-3 [3], clause 8.5.1 shall apply with the following differences:

- i) Fragmentation (DMAC-SYNC + DMAC-END) may also be used for sending the DM-GSETUP message.
- ii) The gateway-specific messages (see note 2) use a single value 11001_2 of the "message type" element. The different gateway-specific messages are then distinguished by the "gateway message subtype" element which immediately follows the "message type" element when the message type has value 11001_2 .
- iii) The DM-TIMING REQUEST message is not used during calls through a gateway.

The usage of PDU elements specific to gateway operation is described in clause 14. See also clause 8.5.2.

For direct MS-MS operation using the protocol defined in EN 300 396-3 [3], the only MAC PDU that can be carried in a DSB is the DMAC-SYNC PDU. The DMAC-SYNC PDU is used also by DM-MSs operating with a gateway. It is also sent by the gateway itself.

The gateway may send an additional MAC PDU in a DSB. This is the gateway presence signal: the DPRES-SYNC PDU. The gateway presence signal comprises layer 2 elements only; refer to clause 14 for a description of the PDU. The contents of the DPRES-SYNC PDU are visible to the DM-MAC in any DM-MS that receives it.

NOTE 1: The contents of a DPRES-SYNC PDU sent by a DM-REP/GATE are visible to the DM-MAC in any DM-MS that receives it, irrespective of the setting of the "master/slave link flag".

For operation with a gateway, the same MAC PDUs may be sent within the normal burst (DNB) as for direct MS-MS operation. This applies to both DM-MSs and gateway.

NOTE 2: A DM-MS may send the following gateway-specific messages: DM-GSETUP, DM-GTX REQUEST, DM-GPREEMPT, DM-GREGISTER REQUEST and DM-GCANCEL ACK.

It may receive the following gateway-specific messages from the gateway: DM-GACK, DM-GCONNECT, DM-GTX ACCEPT, DM-GPRE ACCEPT, DM-GREJECT, DM-GRELEASE, DM-GREGISTER ACCEPT, DM-GREGISTER REJECT and DM-GREGISTER CANCEL.

8.5.2 Addressing

The MAC header in a DMAC-SYNC PDU carrying a gateway-specific message shall contain a single 24-bit SSI: the source address when sent by a DM-MS, or the destination address when sent by a gateway. If the SSI is a true address then the MAC header also contains a 24-bit MNI.

The MAC header in a DMAC-SYNC PDU carrying other messages shall contain a 24-bit destination SSI and a 24-bit source SSI. If either of these is a true address then the MAC header also contains a 24-bit MNI. The source address is optional in a DMAC-DATA PDU.

When the gateway generates a call set-up or occupation message, it may set the source address element to the SSI of the calling party on the TMO system (with the "source address type" element set to value 00_2 to indicate that this is a true SSI). In this case the TMO SSI (with address type 00_2) is used throughout the call transaction as the source address in messages sent by the gateway and as the destination address by DM-MSs wishing to address the gateway.

If the gateway does not use the TMO SSI as the source address then it uses a pseudo SSI (with the "source address type" element set to value 01_2).

8.5.2.1 Transmission of message

When the DM-MAC receives a DMA-UNITDATA request primitive from layer 3, requesting transmission of a gateway-specific message, the primitive does not contain a destination address. For other types of message, the primitive contains the destination address and the destination address type as parameters.

8.5.2.1.1 Addressing in synchronization burst carrying gateway-specific message

When the DM-MAC sends a gateway-specific message (i.e. DM-GSETUP, DM-GTX REQUEST, DM-GPREEMPT, DM-GREGISTER REQUEST or DM-GCANCEL ACK), it shall set the "destination address type" element to 10_2 indicating that no destination address is present. The DM-MAC shall then supply the source address as follows:

- If the DM-MS is prepared to supply its true address as a layer 2 address, the DM-MAC shall set the source address element to its ISSI, the MNI element to its MNI and the "source address type" element to 00_2 .
- Otherwise, the DM-MAC shall make a random choice of a 24-bit "pseudo SSI" for use by layer 2 during that transaction (choosing any value except all zeros or all ones or the gateway's pseudo SSI if applicable). This shall be indicated by setting the "source address type" element to 01_2 .

8.5.2.1.2 Addressing in synchronization burst carrying non-gateway-specific message

In a DM-SETUP, DM-SDS UDATA or DM-SDS DATA message, and in group-addressed occupation messages, the master DM-MAC shall set the MNI and destination SSI elements to the TETRA Subscriber Identity (TSI) of the called party – as provided by layer 3. The "destination address type" element shall be set to 00_2 . The DM-MAC may either use its own ISSI as source address (for an intra-MNI call) or use a pseudo SSI as above (for an inter-MNI call or for an intra-MNI call if the DM-MS does not wish to use its ISSI at layer 2).

A DM-PREEMPT or DM-TX REQUEST random access request message shall include the current master's layer 2 address as the destination address. This shall be the address that the master has been using as its source address – whether a true SSI or a pseudo SSI. The requesting DM-MS may either use its own ISSI as source address or choose a pseudo SSI as above, but not equal to the master's pseudo SSI if applicable.

For a DM-PREEMPT message sent during a registration phase, the requesting DM-MS shall set the "destination address type" element to 01₂ and the destination address to the all-zeros pseudo SSI. This addressing shall apply also for a DM-PREEMPT message sent during a call set-up reservation period if the DM-MS has received only a DM-GACK message. (As always required for operation with a gateway, the DM-MS includes the 10-bit gateway address in the SCH/H block, so the message will be processed only by the correct gateway).

A response message to a random access request shall contain the same addresses as in the invoking message but with source and destination addresses reversed.

A response message to a short data message shall include the master's layer 2 address (whether true or pseudo) as the destination address. The responding DM-MS may either use its own ISSI as source address or choose a pseudo SSI as above, but not equal to the master's pseudo SSI if applicable.

For an individual circuit mode call, if a DM-MS uses a pseudo SSI as the source address, then that SSI remains valid for the duration of the call.

A DM-CONNECT or DM-DISCONNECT message responding to a call set-up with presence check may use a pseudo SSI as the source address in that response message. For a DM-CONNECT message, that SSI then remains valid for the duration of the call, and may be used by the gateway for addressing that DM-MS.

For an individual call set-up without presence check, the called DM-MS may use a pseudo SSI as the source address if it initiates a call transaction in the call. That SSI then remains valid for the duration of the call.

NOTE: This case should not arise since the gateway should use call set-up with presence check for an individual call set-up.

The source address element in a DM-OCCUPIED message shall be the same as in the DM-SETUP message that initiated the current traffic transmission.

8.5.2.1.3 Lifetime of pseudo SSI

The pseudo SSI has a limited lifetime. During its lifetime, the pseudo SSI may be used in other messages sent by that station (DM-MS or gateway) and shall temporarily be used as a destination address by other stations wishing to address that station – with the "destination address type" element set to 01₂.

If a gateway uses a pseudo SSI during a call then that pseudo SSI remains valid for the duration of the call. See also clause 13.5.2.

For group calls, if a DM-MS uses a pseudo SSI as the source address in a DM-GSETUP, DM-GPREEMPT or DM-GTX REQUEST message then, if the DM-MS receives an acceptance of its request, the pseudo SSI becomes invalid at the end of the call transaction; otherwise the pseudo SSI becomes invalid when the DM-MS receives a rejection of the request or if the transmission attempt fails. If a DM-MS starts using a pseudo SSI as the source address for a group call in a DM-SETUP message, then the pseudo SSI becomes invalid at the end of the call transaction when the DM-MS ceases to be master.

If a DM-MS uses a pseudo SSI as the source address in a DM-PREEMPT or DM-TX REQUEST message then, for a group call, the pseudo SSI becomes invalid when the DM-MS receives an acceptance or rejection of the request or if the transmission attempt fails. In the case of acceptance of the request, the DM-MS may choose to use the same pseudo SSI in the following signalling, in which case the pseudo SSI is re-enabled with the DM-MS as master.

For an individual call, if the DM-MS uses a pseudo SSI as the source address in a DM-GSETUP, DM-CONNECT or DM-SETUP message then the pseudo SSI remains valid for the duration of the call and becomes invalid at the end of the call. For an individual call set-up without presence check, if the called DM-MS uses a pseudo SSI as the source address when it initiates a call transaction in the call then that pseudo SSI remains valid for the duration of the call and becomes invalid at the end of the call.

If the DM-MS uses a pseudo SSI as the source address in a DM-SDS DATA or DM-SDS UDATA message sent as a stand-alone transaction then that pseudo SSI becomes invalid at the end of the transaction (after any repetitions).

If the DM-MS uses a pseudo SSI as the source address in a DM-GREGISTER REQUEST message then that pseudo SSI becomes invalid when the DM-MS receives an acceptance or rejection of the request or if the transmission attempt fails.

A DM-MS shall not have more than one pseudo SSI valid at one time.

8.5.2.1.4 Additional elements in synchronization burst

For operation with a DM-GATE, the DM-MAC shall set the "communication type" element to 10_2 in the DMAC-SYNC PDU. For operation with a DM-REP/GATE, the DM-MAC shall set the "communication type" element to 11_2 in the DMAC-SYNC PDU. In either case, the DM-MAC shall include the 10-bit gateway address in the SCH/H block. This rule applies for all DMAC-SYNC PDUs sent during a call or short data or registration transaction through a gateway, including messages sent to pre-empt that call or transaction. It applies also during a registration phase.

NOTE: As defined above, when a DM-MS makes a call through a gateway, it includes the correct 10-bit gateway address within the DMAC-SYNC PDU. The DM-MS needs to know the correct gateway address before making the call, either by prior arrangement or by receiving the gateway presence signal. (The DM-MS also needs to know the gateway type i.e. DM-GATE, type 1A DM-REP/GATE or type 1B DM-REP/GATE).

When sending a DMAC-SYNC PDU, the DM-MAC shall set the "gateway generated message flag" to 0.

The following procedures apply only for operation with a DM-REP/GATE:

- For a transmission by a master DM-MS, the master DM-MAC shall set the "master/slave link flag" to 1 in the DMAC-SYNC PDU and shall use the master link's slot and frame numbering. When the DM-REP/GATE re-transmits the message, it sets the "master/slave link flag" to 0 and uses the slave link's slot and frame numbering. The slave link's slot and frame numbering runs three timeslots behind the master link's slot and frame numbering.
- For a transmission by a slave or idle DM-MS on the slave link, the slave or idle DM-MAC shall set the "master/slave link flag" to 0 in the DMAC-SYNC PDU and shall use the slave link's slot and frame numbering. If a DM-MS is currently master of the channel then the DM-REP/GATE re-transmits the message to the master DM-MS, setting the "master/slave link flag" to 1 and using the master link's slot and frame numbering.

For a transmission by an idle DM-MS on the master link, the idle DM-MAC shall set the "master/slave link flag" to 1 in the DMAC-SYNC PDU and shall use the master link's slot and frame numbering.

8.5.2.1.5 Addressing in normal burst

The mechanisms for addressing in the DMAC-DATA PDU are similar to those in the SCH/H block of the synchronization burst except that, when a normal burst is sent, there has already been a synchronization burst to define the source address and the colour code for the scrambling of normal bursts. It is therefore optional whether the DMAC-DATA PDU includes a source address element. If it does not then the recipient DM-MAC shall implicitly assume the layer 2 source address from the call set-up message (or short data message header).

Normal bursts are only ever sent following a synchronization burst, which defines the gateway address and information about the purpose of the normal burst. Therefore those MAC PDUs that are sent in normal bursts do not include either a "communication type" element or "gateway address" element.

For operation with a DM-REP/GATE, the synchronization burst also defines the link type and slot numbering for that link. Then any following normal bursts for that link shall be sent only in slot 1 of frames 1 to 17 according to that slot and frame numbering. Thus normal bursts on the master link shall only ever be sent in slot 1 of frames 1 to 17 in the master link's slot and frame numbering; and normal bursts on the slave link shall only ever be sent in slot 1 of frames 1 to 17 in the slave link's slot and frame numbering.

8.5.2.2 Reception of message

EN 300 396-3 [3], clause 8.5.2.2 shall apply with the following differences:

- i) When addressed by a gateway-specific message, the DM-MAC does not include a source address parameter in the DMA-UNITDATA indication primitive when it passes the message to layer 3.
- ii) When addressed by a non-gateway-specific message, the recipient DM-MS may use the "gateway generated message flag" to deduce whether a call transaction or short data message originated from a DM-MS or from the TMO system. The DM-MAC provides this information to the higher layers.

NOTE 1: If the "gateway generated message flag" in a call set-up DSB is set to 1 and the "source address type" is set to 00₂ then the source address element contains the calling TMO SSI.

iii) The following differences apply only for operation with a DM-REP/GATE:

- If a master DM-MS receives a DMAC-SYNC PDU with "master/slave link flag" set to 0 then it shall ignore that message (even if it is addressed by the message) except that, during call set-up for a circuit mode call or short data transmission, the master DM-MAC may use the repeated call set-up message on the slave link to deduce the success of its link establishment to the DM-REP/GATE. Also, during circuit mode occupation, if a master DM-MS receives DM-RESERVED on either link then it shall perform the procedure defined in clause 8.4.2.3.
- If a slave or idle DM-MS receives a DMAC-SYNC PDU with "master/slave link flag" set to 1 then it may pass the message to layer 3 or assume a start of fragmentation, but only if all the following conditions are met:
 - the message is addressed to one of its group addresses by the message;
 - the DM-MS supports monitoring of the master link;
 - the DM-MS is unable to receive the corresponding message transmitted by the DM-REP/GATE on the slave link, see clause 8.5.6.2.

NOTE 2: Note however that, after reception of a DMAC-SYNC PDU a slave or idle DM-MS no longer regards the channel as free; refer to clause 8.4.2.

- If a master DM-MS receives a DMAC-DATA PDU, and if the reception slot was not a slot 1 in the master link's slot numbering, then it shall ignore that message even if it is addressed by the message.
- If a slave or idle DM-MS receives a DMAC-DATA PDU, and if the reception slot was not a slot 1 in the slave (or master) link's slot numbering, then it shall ignore that message even if it is addressed by the message.

8.5.2.3 Usage of MNI

For operation with a gateway, the MNI element is conditional in both the DMAC-SYNC and DMAC-DATA PDU. It shall be included if either the source or destination address is a true address i.e. if the "source address type" element = 00₂ and/or the "destination address type" element = 00₂.

NOTE: This contrasts with direct MS-MS and DM-REP operation where an MNI is always present in both DMAC-SYNC and DMAC-DATA, though it need not be a true MNI.

8.5.3 Use of air interface encryption

EN 300 396-3 [3], clause 8.5.3 shall apply.

NOTE: In order to function correctly, the gateway needs to be able to decrypt signalling messages for calls using that gateway. Therefore the gateway needs to hold the appropriate air interface encryption information.

When using air interface encryption, the encryption key numbers for all DM-MSs using a particular gateway need to be co-ordinated so that the encryption key numbering is unique for that gateway.

8.5.4 Fragmentation and reconstruction

8.5.4.1 Fragmentation by a DM-MS

For operation with a DM-GATE, EN 300 396-3 [3], clause 8.5.4.1 shall apply.

For operation with a DM-REP/GATE, EN 300 396-3 [3], clause 8.5.4.1 shall apply with the following differences for method 1):

- i) When sending a fragmented DM-SDS UDATA or DM-SDS DATA message, the master DM-MAC shall send the first fragment in DMAC-SYNC PDUs in the usual way, but using the master link. So it shall set the "fragmentation flag" to indicate start of fragmentation and the "number of SCH/F slots" element to indicate the number of following fragments and shall use the frame countdown mechanism to indicate when the repetitions of the DMAC-SYNC have been completed.

Then, if the frame containing the master's final transmission of the DMAC-SYNC PDU was master link frame X, the master shall send the first DMAC-FRAG PDU (or DMAC-END PDU) on SCH/F in slot 1 of master link frame Y = $(X + DN233) \bmod 18 + 1$ (if Y is in the range 1 to 17) or otherwise in slot 1 of master link frame 1. The master DM-MAC shall then continue to send any further fragments on SCH/F on the master link, in consecutive slot 1 of frames 1 to 17 and without repetition, following the procedure defined in EN 300 396-3 [3], clause 8.5.4.1.

NOTE 1: DN233 is the number of frames in which the DM-REP/GATE transmits the DMAC-SYNC PDU on the slave link. For example, if DN233 = 2, and if the master DM-MAC sends its final DMAC-SYNC in master link frame 18, then it starts transmitting SCH/F in slot 1 of master link frame 3.

For correct operation of the short data protocol, it is essential that the master DM-MAC assumes the same value of DN233 as the DM-REP/GATE.

- ii) If repeating transmission of an unacknowledged data message, the DM-MAC need not transmit in slot 1 of the first transmission frame.

NOTE 2: For an acknowledged short data message sent through a gateway, the DM-MS expects to receive a DM-SDS ACK (or DM-REJECT) message from the gateway. This may be used to deduce the success or failure of link establishment to the gateway.

In an implementation, when the DM-MS sends an unacknowledged short data message through a DM-REP/GATE, the DM-MS may choose to monitor the slave link to look for its DMAC-SYNC PDU to be re-transmitted on the slave link and abort transmission of the message if it does not receive any of the repeated DMAC-SYNC PDUs. The DM-MS may also choose to look on the slave link for the re-transmission of its DMAC-END. Receipt of the DMAC-END on the slave link could be used as an implicit acknowledgement that the DM-REP/GATE has received the entire DM-SDU (since the DM-REP/GATE stops re-transmission if it fails to decode any of the SCH/F slots). If using this option, and if repeating the message transmission, many DM-MSs will not be able to transmit in the immediately following slot 1 of the master link.

- iii) When sending a fragmented DM-SDS ACK message, the slave DM-MAC shall use the slave link. It shall follow the procedure defined in EN 300 396-3 [3], clause 8.5.4.1. (So the DM-MAC sets the "fragmentation flag" to indicate start of fragmentation and the "number of SCH/F slots" element to 0001_2 , sends the DMAC-SYNC PDU the appropriate number of times using the frame countdown mechanism and then sends the DMAC-END PDU in slot 1 of the first slave link frame in the range 1 to 17 following the frame with "frame countdown" element set to 00_2).

In addition, for operation with either a DM-GATE or a DM-REP/GATE, when sending a fragmented DM-GSETUP message, the DM-MS shall follow the procedure defined in EN 300 396-3 [3], clause 8.5.4.1. (I.e. it shall set the "fragmentation flag" to indicate start of fragmentation and the "number of SCH/F slots" element to 0001_2 , send the DMAC-SYNC PDU the appropriate number of times using the frame countdown mechanism and then send the DMAC-END PDU in slot 1 of the first frame in the range 1 to 17 following the frame with "frame countdown" element set to 00_2). Layer 3 is responsible for requesting a retransmission if a response is not received from the gateway. The DM-MAC shall therefore issue a final DMA-REPORT indication primitive to layer 3 after a single transmission of the complete message.

NOTE 3: The DM-MS is a slave when sending DM-GSETUP. Therefore, for operation with a DM-REP/GATE, the DM-MS uses the slave link and the above paragraph refers to slots and frames on the slave link.

8.5.4.2 Reconstruction by a DM-MS

NOTE 1: The received message may have been generated by the gateway (e.g. for a short data message originated in the TMO system), or may have been originated by a DM-MS.

For operation with a DM-GATE, EN 300 396-3 [3], clause 8.5.4.2 shall apply except that, if the DM-MAC receives a DM-SDS DATA message for one of its addresses, but originated by a DM-MS (i.e. with "gateway generated message flag" set to 0), then it may process the message and deliver it to layer 3 but shall indicate the received message type to layer 3 as being DM-SDS UDATA. This exception shall apply for both fragmented and non-fragmented DM-SDS DATA messages.

NOTE 2: This case may occur if the master DM-MS sends the message through the gateway on the assumption that the called party is on the TMO system whereas the called party is actually on the DM channel. The called DM-MS is permitted to receive the short data message and deliver it to the user application but does not send an acknowledgement since the gateway will be responding.

This case may also occur if the master DM-MS chooses to use the acknowledged service when sending group-addressed short data through the gateway, in order to obtain an acknowledgement from the gateway. Local DM-MSs addressed by the message may deliver the short data message to the user application but do not send acknowledgements.

For operation with a DM-REP/GATE, if the DM-MS receives a non-fragmented message then EN 300 396-3 [3], clause 8.5.4.2 shall apply except that, if the DM-MAC receives a DM-SDS DATA message for one of its addresses, but originated by a DM-MS (i.e. with "gateway generated message flag" set to 0), then it may process the message and deliver it to layer 3 but shall indicate the received message type to layer 3 as being DM-SDS UDATA.

For operation with a DM-REP/GATE, the appropriate reconstruction procedure shall apply as follows for a DM-MS that supports reconstruction:

- a) When receiving a fragmented DM-SDS DATA or DM-SDS UDATA message generated by the gateway (i.e. with "gateway generated message flag" set to 1), the slave DM-MAC shall obey the procedure defined in EN 300 396-3 [3], clause 8.5.4.2 without amendment. (So, if the DMAC-SYNC PDU indicating start of fragmentation was received in frame X of the slave link and contained "frame countdown" element F, the slave DM-MAC shall look for the first DMAC-FRAG/DMAC-END in slot 1 of slave link frame $Y = (X+F) \bmod 18 + 1$ (if Y is in the range 1 to 17) or otherwise in slot 1 of slave link frame 1. The slave DM-MAC shall then continue to follow the procedure defined in EN 300 396-3 [3], clause 8.5.4.2).
- b) When receiving a fragmented DM-SDS UDATA message originated by a DM-MS (i.e. with "gateway generated message flag" set to 0), the slave DM-MAC shall obey the procedure defined in EN 300 396-3 [3], clause 8.5.4.2 except that:
 - i) If the DMAC-SYNC PDU indicating start of fragmentation was received in frame X of the slave link and contained "frame countdown" element F, the slave DM-MAC shall look for the first DMAC-FRAG/DMAC-END in slot 1 of slave link frame $Y = (X+F+1) \bmod 18 + 1$ (if Y is in the range 1 to 17) or otherwise in slot 1 of slave link frame 1. The slave DM-MAC shall then continue to follow the procedure defined in EN 300 396-3 [3], clause 8.5.4.2.
 - ii) If the DMAC-SYNC PDU indicating start of fragmentation was received in frame X of the master link and contained "frame countdown" element F, if the DM-MAC does not subsequently receive the DMAC-SYNC PDU on the slave link in the next F+DN233 frames, a monitoring slave DM-MAC may look (depending on its ability to monitor the master link) for the first DMAC-FRAG/DMAC-END in slot 1 of master link frame $Y = (X+F+DN233) \bmod 18 + 1$ (if Y is in the range 1 to 17) or otherwise in slot 1 of master link frame 1. The monitoring slave DM-MAC shall then continue to follow the procedure defined in EN 300 396-3 [3], clause 8.5.4.2.

NOTE 3: A monitoring slave DM-MAC that has not received a presence signal from the DM-REP/GATE and assumes a different value of DN233 to the DM-REP/GATE will not correctly receive the SDS.

- iii) On receipt of a DMAC-END PDU, the DM-MAC shall check that it has received the number of SCH/F slots indicated by the "number of SCH/F slots" element S from the DMAC-SYNC PDU i.e. that it received $S - 1$ DMAC-FRAG PDUs before receiving the DMAC-END PDU. If the received number of SCH/F slots matches the "number of SCH/F slots" element then the DM-MAC shall deliver the reconstructed DM-SDU to layer 3 using a DMA-UNITDATA indication primitive. If the received number of SCH/F slots does not match the "number of SCH/F slots" element then the DM-MAC shall discard the message (without an indication to layer 3).
- c) When receiving a fragmented DM-SDS DATA message originated by a DM-MS (i.e. with "gateway generated message flag" set to 0), the slave DM-MAC may obey the reconstruction procedure defined in procedure b) above for a fragmented DM-SDS UDATA message originated by a DM-MS. If the slave DM-MAC processes the message and delivers it to layer 3 then the DM-MAC shall indicate the received message type to layer 3 as being DM-SDS UDATA.
- d) When receiving a fragmented DM-SDS ACK message, the master DM-MAC shall obey the procedure defined in EN 300 396-3 [3], clause 8.5.4.2 without amendment. (So, if the DMAC-SYNC PDU indicating start of fragmentation was received in frame X of the master link and contained "frame countdown" element F, the master DM-MAC shall look for the DMAC-END in slot 1 of master link frame $Y = (X+F) \bmod 18 + 1$ (if Y is in the range 1 to 17) or otherwise in slot 1 of master link frame 1).

8.5.5 Fill bit addition and deletion

EN 300 396-3 [3], clause 8.5.5 shall apply.

8.5.6 Transmission and reception of messages by layer 2 unacknowledged service

When the DM-MAC receives a DMA-UNITDATA request primitive from layer 3, it shall use its current state and the message type parameter to decide how to send the message:

- a) For the initiation of a new circuit mode call (i.e. first transmission of message DM-GSETUP), or for a non-immediate retransmission of DM-GSETUP, the DM-MAC shall check whether the channel is free (as defined in clause 8.4.2) before transmitting the DM-GSETUP message as a slave.
- b) For an immediate retransmission of DM-GSETUP, the DM-MAC shall time its transmission using the "frame countdown" element from the received DM-GACK.
- c) When sending DM-SETUP, the DM-MAC shall transmit the message as master, using DSBs and timing its transmission using the "frame countdown" element from the received DM-GCONNECT, DM-GPRE ACCEPT or DM-GTX ACCEPT message.
- d) For the initiation of a stand-alone short data message, or for a non-immediate retransmission of DM-SDS DATA, the DM-MAC shall check whether the channel is free (as defined in clause 8.4.2) before transmitting the DM-SDS DATA or DM-SDS UDATA message as master.
- e) For short data sent after changeover or pre-emption, the DM-MAC shall transmit the DM-SDS DATA or DM-SDS UDATA message as master, timing its transmission using the "frame countdown" element from the received DM-TX ACCEPT or DM-PRE ACCEPT message.
- f) If the DM-MS is already a master, the DM-MAC may transmit the message and shall use the appropriate burst(s). For example, this may apply to DM-SDS UDATA, DM-OCCUPIED, DM-TX CEASED, DM-RELEASE, DM-PRE ACCEPT, DM-REJECT and DM-INFO messages.
- g) If the DM-MS is not the master and the message is a response to a message from the gateway (i.e. the message is DM-CONNECT, DM-DISCONNECT, DM-SDS ACK, DM-REJECT or DM-GCANCEL ACK), the DM-MAC shall transmit the message as a slave, timing the response using the "frame countdown" element from the invoking message.
- h) If the message is a DM-PREEMPT, DM-TX REQUEST or DM-GPREEMPT message, or a DM-GTX REQUEST message not sent after pre-emption of a master DM-MS, the DM-MAC shall use the appropriate random access protocol for sending the message.

- j) If the message is a DM-GTX REQUEST sent after pre-emption of a master DM-MS, the DM-MAC shall transmit the message as a slave, timing its message using the "frame countdown" element from the DM-PRE ACCEPT. The DM-MAC shall then revert to obeying the random access protocol (as described in clause 8.5.7.3), regarding its multiple transmission of the DM-GTX REQUEST as if it had been a single random access transmission in slot 3 of the final signalling frame.
- k) If the message is a solicited DM-GREGISTER REQUEST message (i.e. sent during a registration phase), the DM-MAC shall use the registration access control protocol for sending the message.
- l) If the message is an unsolicited DM-GREGISTER REQUEST message (i.e. sent outside a registration phase), the DM-MAC shall check whether the channel is free (as defined in clause 8.4.2) before transmitting the message as master.

In the random access protocol or registration access control protocol (cases h), j) and k)), the DM-MAC sends retries until a response is received or the access attempt fails. These protocols are described in:

- clause 8.5.7.3 for DM-TX REQUEST, DM-GPREEMPT or DM-GTX REQUEST;
- clause 8.5.7.3 for DM-PREEMPT sent during a circuit mode call or short data transmission;
- clause 8.5.8.2 for DM-PREEMPT sent during a registration phase; and
- clause 8.5.8.1 for a solicited DM-GREGISTER REQUEST.

For the other types of transmission, the service provided by the DM-MAC to layer 3 is an unacknowledged service. The DM-MAC transmits the message the appropriate number of times and shall then report to layer 3 when the message has been sent (DMA-REPORT indication primitive). The acknowledgement protocol (if any) and any resulting retransmission is under the control of layer 3. If the DM-MAC is unable to send the message (e.g. in case a) or d) if the channel becomes busy) then it shall report the failure to layer 3.

This clause describes the tools for the layer 2 unacknowledged service.

NOTE 1: When sending a short data message or DM-SETUP message through a DM-REP/GATE, the master DM-MAC may choose to look for the repeated DSB (and possibly DMAC-END) on the slave link. In an implementation, additional DMA-REPORT indications may then be used to inform layer 3 of the perceived success or failure of the link establishment to the DM-REP/GATE.

NOTE 2: Cases a), d) and l) are the only cases when the DM-MAC is required to check whether the channel is free before transmitting.

8.5.6.1 Transmission of message

EN 300 396-3 [3], clause 8.5.6.1 shall apply with the following differences:

- i) For a fragmented message, the "frame countdown" element refers only to repetitions of the DMAC-SYNC PDU. For operation with a DM-GATE, the first DMAC-FRAG PDU (or DMAC-END PDU) shall be sent in slot 1 of the first frame in the range 1 to 17 following the frame with "frame countdown" element set to 00₂ (i.e. as defined in EN 300 396-3 [3]). For operation with a DM-REP/GATE, the timing of the first DMAC-FRAG PDU (or DMAC-END PDU) shall be as defined in clause 8.5.4.1.
- ii) The DM-MAC does not send DM-TIMING ACK, DM-TX ACCEPT or DM-RESERVED messages.

For operation with a DM-REP/GATE, transmissions by the master DM-MS use the master link slot and frame numbering; transmissions by a slave DM-MS use the slave link slot and frame numbering.

NOTE: For operation with a DM-GATE or type 1A DM-REP/GATE, the DM-MS transmits on the selected DM RF carrier. For operation with a type 1B DM-REP/GATE, the DM-MS transmits on the DM uplink RF carrier f_1 .

8.5.6.2 Reception of message

NOTE 1: For operation with a DM-GATE or type 1A DM-REP/GATE, the DM-MS receives on the selected DM RF carrier. For operation with a type 1B DM-REP/GATE, the DM-MS normally receives on the selected DM downlink RF carrier f_2 , however the DM-MS may receive on the selected DM uplink RF carrier f_1 if it is unable to receive transmissions from the DM-REP/GATE.

The recipient DM-MAC may use the "frame countdown" element F in received messages in several ways:

a) Suppression of duplicates:

EN 300 396-3 [3], clause 8.5.6.2 a) shall apply with the following addition:

A DM-MAC that supports monitoring of the master link, in the case of transactions via a DM-REP/GATE, may delay delivering a message to layer 3 for up to $F+DN232$ frames after receiving a via DM-REP/GATE DM-SETUP or DM-SDS UDATA on the master link addressed to a one of its addresses, to see if it is able to receive that message on the slave link from the DM-REP/GATE.

b) Delaying switch into traffic mode:

When the DM-MS receives a message indicating that it should change into traffic mode (i.e. DM-SETUP or DM-CONNECT ACK), it shall use the timing defined in clause 8.6.3.

c1) Timing of setup signalling, or short data signalling after pre-emption or changeover:

When the DM-MS receives a DM-GCONNECT, DM-GPRE ACCEPT or DM-GTX ACCEPT message from the gateway, giving it permission to send call set-up signalling, the DM-MAC shall use the "frame countdown" element F from the received message to deduce when its DM-SETUP messages can be sent without colliding with the gateway's repeat transmissions.

Similarly, when the DM-MS receives a DM-PRE ACCEPT within a call or DM-TX ACCEPT message from the current master (gateway or DM-MS), giving it permission to send a short data message, the DM-MAC shall use the "frame countdown" element F from the received message to deduce when its DM-SDS UDATA or DM-SDS DATA signalling can be sent.

When the DM-MS receives a DM-PRE ACCEPT for a new call pre-emption from the current master (gateway or DM-MS), the DM-MAC shall use the "frame countdown" element F from the received message to deduce when its DM-GSETUP or DM-SETUP messages can be sent.

For operation with a DM-GATE, and if the permitting message was received in frame X, then the transmission of the DSBs shall start in either frame $(X+F) \bmod 18 + 1$ or frame $(X+F+1) \bmod 18 + 1$.

For operation with a DM-REP/GATE, the DM-MS shall adopt the state of the timing counters currently in use on the master link. In the case of a pre-emption on the slave link, this requires an increase of three timeslots relative to the state of the slot and frame counters currently indicated by the DM-REP/GATE on the slave link (i.e. counter TN shall be incremented three times). Then, if the permitting message was received in frame X on the slave link, the transmission of the DSBs shall start in either master link frame $(X+F+1) \bmod 18 + 1$ or master link frame $(X+F+2) \bmod 18 + 1$. In the case of a pre-emption on the master link, the DM-MS shall adopt the state of the timing counters currently in use on the master link and if the permitting message was received in frame X on the master link the transmission of the set-up DSBs shall start in master link frame $(X+F+1) \bmod 18 + 1$.

c2) Timing of DM-GTX REQUEST sent after pre-emption of another DM-MS:

When the DM-MAC is required to send DM-GTX REQUEST after successful pre-emption of another DM-MS, it shall use the "frame countdown" element F from the received DM-PRE ACCEPT message (received in frame X) to deduce when its signalling can be sent. The transmission of the DM-GTX REQUEST messages shall start in either frame $(X+F) \bmod 18 + 1$ or frame $(X+F+1) \bmod 18 + 1$. (For operation with a DM-REP/GATE, these frame numbers all refer to the slave link).

d1) Timing of immediate retransmission of DM-GSETUP:

When the DM-MAC is required to send an immediate retransmission of a DM-GSETUP message after receipt of a DM-GACK message, it shall use the "frame countdown" element F from the DM-GACK message (received in frame X) to deduce when its signalling can be sent. The transmission of the DM-GSETUP DSBs shall start in either frame $(X+F) \bmod 18 + 1$ or frame $(X+F+1) \bmod 18 + 1$. (For operation with a DM-REP/GATE, these frame numbers all refer to the slave link).

d2) Timing of immediate SDS retransmission:

EN 300 396-3 [3], clause 8.5.6.2 d) shall apply. For operation with a DM-REP/GATE, the timings given refer to reception of the DM-SDS ACK on the master link, and then retransmission of the DM-SDS DATA message on the master link.

e) Timing of response to non-fragmented message from gateway:

EN 300 396-3 [3], clause 8.5.6.2 e) shall apply. For operation with a DM-REP/GATE, the timings given refer to reception of the gateway's message in frame X on the slave link, and then transmission of the response on the slave link (with the first response DSB(s) sent in slave link frame $(X+F) \bmod 18 + 1$).

As defined in clause 8.4.5.1, the response DSB should also be sent in slot 2 in each of the DSB signalling frames (unless, for the first DSB signalling frame, the DM-MS is linearizing in that slot) and in slot 4 in each of the DSB signalling frames except that, for a non-fragmented response, slot 4 of the final DSB signalling frame shall not be used.

NOTE 2: These timings apply to the transmission of a DM-CONNECT or DM-DISCONNECT message in response to a DM-SETUP PRES message, and to the transmission of a DM-SDS ACK or DM-REJECT message in response to non-fragmented DM-SDS DATA message (as in EN 300 396-3 [3]). They also apply to the transmission of a DM-GCANCEL ACK message in response to a DM-GREGISTER CANCEL message.

NOTE 3: As in EN 300 396-3 [3], the responding DM-MS may linearize in slot 1 of frame $(X+F) \bmod 18 + 1$. It may also be permitted to linearize in slot 2 of that frame; see clause 8.4.7.4.

f) Timing of response to fragmented message from gateway:

For a fragmented message headed by the DMAC-SYNC PDU, the "frame countdown" element F refers only to the DMAC-SYNC. This then indicates where the first DMAC-FRAG PDU (or DMAC-END PDU) may be expected, as specified in clause 8.5.4.2.

The procedure for timing the response to a fragmented DM-SDS DATA message shall be as described in EN 300 396-3 [3], clause 8.5.6.2 f) with the following addition:

- If, after a reconstruction failure, the DM-MAC receives any DM-GPRE ACCEPT or DM-GSETUP DSB then it shall refrain from transmitting and shall discard the response DM-SDS ACK. (This requirement is additional to the EN 300 396-3 [3] procedure if the DM-MAC receives any DM-PRE ACCEPT, DM-SETUP, DM-SETUP PRES, DM-SDS DATA or DM-SDS UDATA DSB).

As defined in clause 8.4.5.1, the response DSB should also be sent in slot 2 in each of the DSB signalling frames (unless, for the first DSB signalling frame, the DM-MS is linearizing in that slot) and in slot 4 in each of the DSB signalling frames except that, for a non-fragmented response, slot 4 of the final DSB signalling frame shall not be used.

For operation with a DM-REP/GATE, the timings given refer to reception of the gateway's message on the slave link, and then transmission of the response on the slave link.

Points e) and f) define when the first transmission of a response message must be sent. According to the protocol description, it is assumed that, when the DM-MS has received a DM-SDS DATA message addressed to itself, and if layer 3 does not immediately return a response DM-SDS ACK, then the DM-MAC shall issue a DMC-REPORT indication primitive as a prompt to layer 3 in time to allow transmission in the correct slot(s).

8.5.7 Random access protocol during occupation and reservation periods

8.5.7.1 Introduction

During both the occupation and reservation periods, a DM-MS that wishes to transmit traffic or short data must first request and be granted permission by the current master before performing a set-up procedure and becoming master of the channel itself. It requests permission using the random access protocol.

For operation with a gateway, the DM-MS sends:

- the DM-PREEMPT message if pre-empting another DM-MS in order to continue with the ongoing call, or for a pre-emption to send short data as a transaction within the ongoing call, or for any new call pre-emption; or
- the DM-TX REQUEST message if requesting changeover in order to send short data as a transaction within the ongoing call; or
- the DM-GPREEMPT message if pre-empting the gateway in order to send circuit mode traffic within the ongoing call; or
- the DM-GTX REQUEST message if requesting changeover in order to send circuit mode traffic.

The channel may be in reservation during call set-up – for calls either to or from the gateway – and also following call transactions. The gateway is master of the channel during all reservation periods. Only pre-emption requests will be invited by the gateway when the channel is in reservation during call set-up (as announced by DM-RESERVED messages with element "channel reservation type" set to 1 or by DM-GACK messages with element "reservation period announced" set to 1); whereas both pre-emption and changeover requests may be invited during the reservation period following a call transaction (as announced by DM-TX CEASED, or by DM-RESERVED messages with element "channel reservation type" set to 0). The "requests flag" and "changeover requests flag" in DM-GACK, DM-RESERVED and DM-TX CEASED messages sent by the gateway indicate when requests are invited.

Only pre-emption requests may be sent during short data occupation or while the channel is in circuit mode occupation. During occupation the master of the channel may be either the gateway or a DM-MS.

For operation with a DM-GATE, a requesting slave or idle DM-MS sends its random access message in an appropriate slot 3. The current master of the channel – either gateway or DM-MS – then sends a response.

For operation with a DM-REP/GATE, normally a requesting slave or idle DM-MS sends its random access message on the slave link in an appropriate slot 3. If the DM-REP/GATE is master of the channel then it sends a response on the slave link. Otherwise, if a DM-MS is master of the channel then the DM-REP/GATE repeats the random access message on the master link (without sending any form of interim response to the slave). It is the responsibility of the master DM-MS to decide whether to accept the request and then to send a response (on the master link). The DM-REP/GATE then repeats the response on the slave link.

For operation with a DM-REP/GATE, the usual numbering for pre-emption slots as slot 3 of frames 2, 5, 8, 11, 14 and 17 (and additional request slots as slot 3 of frames 1, 4, 7, 9, 10, 13, 15 and 16) still applies to the slave link. However, from the perception of a master DM-MS during occupation, there is generally a two-frame delay relative to the numbering for direct DM-MS operation.

Alternatively, an idle DM-MS that is unable to receive on the slave link may send its random access message on the master link in an appropriate slot 3, bypassing the DM-REP/GATE. In this case the pre-emption slots are slot 3 of frames 4, 10 and 16 indicated by the "pre-emption flag" being set (and additional request slots as slot 3 of frames 9, 11, 15 and 17 indicated by "requests bitmap" element having the corresponding slave link frame bit set as per table 1 in clause 9.5.2.3).

NOTE: Frames 1, 7 and 13 have been omitted from the master link pre-emption slots as they are used by the DM-REP/GATE to send its presence signal.

8.5.7.2 Procedures for master DM-MS

This clause defines the random access procedures for a DM-MS when it is master of the channel during occupation in a call through a gateway. The random access procedures for the gateway when it is master of the channel are defined in clause 13.5.7.

8.5.7.2.1 Indicating frames available for requests

When the DM-MAC transmits DM-SETUP and DM-OCCUPIED messages:

- it shall set the "timing flag" to 0 to indicate that timing change requests are not allowed;
- it shall set the "pre-emption flag" to 1 to indicate that slot 3 of frames 2, 5, 8, 11, 14 and 17 is available for pre-emption requests during the occupation period.

NOTE 1: This requirement may be relaxed for some types of call in future editions of the present document.

NOTE 2: For operation with a DM-REP/GATE, this refers to slot 3 of frames 2, 5, 8, 11, 14 and 17 on the slave link.

When the master DM-MAC transmits DM-TX CEASED, it shall set the "requests flag" and "changeover requests flag" to 0 to indicate that random access requests shall not be sent to itself during the subsequent reservation period. After completing the transmissions of the DM-TX CEASED message, the DM-MS shall stop being master (since the gateway becomes master, sending DM-RESERVED messages inviting random access requests if appropriate).

8.5.7.2.2 Monitoring frames available for requests

During occupation for a circuit mode call:

- for operation with a DM-GATE, the master DM-MAC shall monitor slot 3 of frames 2, 5, 8, 11, 14 and 17 for pre-emption requests addressed to itself or for a message from the DM-GATE; it shall also monitor slot 3 of frames 1, 7 and 13 for a message from the DM-GATE;
- for operation with a DM-REP/GATE, the master DM-MAC shall monitor slot 3 of frames 1, 4, 7, 10, 13 and 16 on the master link for pre-emption requests addressed to itself or for a message from the DM-REP/GATE.

NOTE 1: The master DM-MAC is not required to monitor slot 3 during the transmission of the DM-TX CEASED message at the end of circuit mode occupation.

When sending SCH/F for a fragmented DM-SDS UDATA or DM-SDS DATA message:

- for operation with a DM-GATE, the master DM-MAC shall monitor slot 3 of frames 2, 5, 8, 11, 14 and 17 for pre-emption requests addressed to itself or for a message from the DM-GATE; it shall also monitor slot 3 of frames 1, 7 and 13 for a message from the DM-GATE;
- for operation with a DM-REP/GATE, the master DM-MAC shall monitor slot 3 of frames 1, 4, 7, 10, 13 and 16 on the master link for pre-emption requests addressed to itself or for a message from the DM-REP/GATE.

NOTE 2: If the protocol requires the DM-MS to transmit in any of the monitoring slots specified in this clause, the transmission takes precedence over the monitoring requirement.

8.5.7.2.3 Response to pre-emption request

For operation with a DM-GATE: on receipt of a pre-emption request DM-PREEMPT addressed to itself (from either a DM-MS or the gateway) while the DM-MS is master during circuit mode occupation or short data occupation, the appropriate procedures described in EN 300 396-3 [3], clause 8.5.7.2.3 shall apply.

NOTE: EN 300 396-3 [3], clause 8.5.7.2.3 covers also the procedures for a master DM-MS after receipt of a pre-emption or changeover request during reservation; these procedures do not apply since the gateway is always master during reservation.

For operation with a DM-REP/GATE: on receipt of a pre-emption request DM-PREEMPT addressed to itself (from either a DM-MS or the gateway) while the DM-MS is master during circuit mode occupation or short data occupation, the appropriate procedures described in EN 300 396-3 [3], clause 8.5.7.2.3 shall apply with the following differences:

- References to transmission by the master DM-MAC in "slot 1" or "slot 3" refer to slot and frame numbering on the master link.

- ii) After accepting a pre-emption request, the DM-MS shall stop being master (as defined in EN 300 396-3 [3], clause 8.5.7.2.3) and starts to receive on the slave link. In normal cases, the DM-MS should expect the slot and frame numbering on the slave link to run exactly three timeslots behind the slot and frame numbering that it has been using on the master link. The exception occurs for a DM-PREEMPT message from the gateway if the gateway included a "timing adjustment" element in the message. Then the old master should expect the timing on the slave link to be modified also according to the "timing adjustment" element.
- iii) In b), if the master DM-MS sends the DM-REJECT message in slot 3, then it may use frames 2, 5, 8, 9, 11, 14, 15 or 17.

8.5.7.2.4 Response to timing change request

Timing change requests are not invited during calls through a gateway. Therefore EN 300 396-3 [3], clause 8.5.7.2.4 does not apply.

8.5.7.2.5 Response to DM-GRELEASE message

On receipt of a DM-GRELEASE message, the master DM-MAC shall deliver the message to layer 3 in a DMA-UNITDATA indication primitive. If the message is valid, layer 3 then issues a DM-RELEASE message in a DMA-UNITDATA request primitive. The DM-MAC shall send the DM-RELEASE message in the usual way, in timeslots 1 and 3 in at least two frames; see clause 8.4.5.1.

8.5.7.3 Procedures for requesting DM-MS

This clause defines the procedures for a requesting DM-MS to make a random access attempt during a call through a gateway. When sending a pre-emption request DM-PREEMPT, the DM-PREEMPT message is addressed to the current master, which may be either the gateway or a DM-MS. The procedures in EN 300 396-3 [3], clause 8.5.7.3 shall apply with the following differences:

- i) In clause 8.5.7.3.6, criterion c) for ceasing attempting random access shall be replaced by the following criterion:
 - c) The DM-MAC receives a DM-PRE ACCEPT message with the current master as source but addressed to another DM-MS, or it receives a DM-TX ACCEPT, DM-GCONNECT, DM-GPRE ACCEPT or DM-GTX ACCEPT message with the gateway as source and addressed to another DM-MS.
- ii) In clause 8.5.7.3.6, criterion f) for ceasing attempting random access shall be replaced by the following criterion:
 - f) The user application indicates that the random access attempt is to be abandoned, or the DMCC has indicated that no further random access transmissions are permitted for the current attempt and no response has been received.
- iii) For operation with a DM-REP/GATE, in the case of random access on the slave link when a DM-MS is master in short data occupation, the following differences shall apply in the third indented paragraph of clause 8.5.7.3.3 (i.e. "During short data occupation"):
 - The expression "those frames in which the master intends to send SCH/F in slot 1" refers to the expected SCH/F slots as re-transmitted by the DM-REP/GATE on the slave link.
 - The requesting DM-MS may also (optionally) regard slot 3 of the frame preceding the first SCH/F slot as a "valid access slot", if that frame has slave link frame number 2, 5, 8, 11, 14 or 17.
 - The requesting DM-MS shall not regard either slot 3 of the slave link frame containing the final SCH/F slot or slot 3 of the slave link frame preceding the final SCH/F slot as "valid access slots".

In the case of random access to send a pre-emption request on the master link, EN 300 396-3 [3], clause 8.5.7.3.3 shall apply with the following differences:

- During circuit mode occupation the valid access slots are slot 3 of master link frames 4, 10 and 16 if allowed by the "pre-emption flag". The access slots may be used after the DM-REP/GATE has had time to complete its repetitions of the transmissions of the DM-SETUP or DM-CONNECT ACK message.

- During short data occupation the potentially valid access slots are slot 3 of master link frames 4, 10 and 16.
- iv) For operation with a DM-REP/GATE, in the case of random access on the slave link when a DM-MS is master, the following differences shall apply in clause 8.5.7.3.4:
- During circuit mode occupation when a DM-MS is master, the time-out waiting for a random access response shall be increased by 2 frame durations i.e. text "time DT211" shall be replaced by text "time DT211 + 2".
 - During short data occupation when a DM-MS is master, the time-out waiting for a random access response shall be increased by 2 frame durations i.e. text "time DT212" shall be replaced by text "time DT212 + 2".

In the case of random access on the master link, EN 300 396-3 [3], clause 8.5.7.3.4 shall apply.

NOTE 1: Differences iii) and iv) do not apply when the DM-REP/GATE is master.

When sending a changeover request DM-TX REQUEST, the procedures in EN 300 396-3 [3] clause 8.5.7.3 shall apply except that, in clause 8.5.7.3.6, criterion c) shall be revised as above. The DM-TX REQUEST message is addressed to the current master, which is always the gateway.

When sending a pre-emption request DM-GPREEMPT, the same protocol shall apply as for DM-PREEMPT (with the revised criterion c)) except that, in clause 8.5.7.3.4, valid response messages are DM-GACK, DM-GPRE ACCEPT or DM-GREJECT from the gateway.

When sending a changeover request DM-GTX REQUEST, the same protocol shall apply as for DM-TX REQUEST (with the revised criterion c)) except that, in clause 8.5.7.3.4, valid response messages are DM-GACK, DM-GTX ACCEPT or DM-GREJECT from the gateway.

NOTE 2: When sending DM-GPREEMPT or DM-GTX REQUEST, the DM-MS includes its own address or pseudo SSI as the layer 2 source address and does not include a destination address. In a response it therefore expects to see its own address or pseudo SSI as the layer 2 destination address and no source address. As usual, all these messages contain the 10-bit gateway address.

The following points may be noted for operation with a gateway (either a DM-GATE or DM-REP/GATE):

- The protocol for recent user priority is as defined in EN 300 396-3 [3], clause 8.5.7.3.2. So, for example, if the DM-TX CEASED message had the "recent user priority flag" set to 1, and if the DM-MS is sending a recent user changeover request DM-GTX REQUEST, then the DM-MAC shall transmit the request in the first valid access slot. Note however that, if the DM-TX CEASED was sent by another DM-MS, then the first valid access slot will not occur until after receipt of a DM-RESERVED message from the gateway (and completion of the frame countdown on the DM-RESERVED message).
- The same messages define the currently permitted types of random access as in EN 300 396-3 [3].

Additionally, the DM-GACK message may invite random access requests e.g. when sent during a reservation period for a call set-up through the gateway. (If a DM-GACK message does not include random access parameters then the last random access parameters (if any) received within this occupation or reservation period remain unchanged). If the DM-MS receives a DM-GACK message containing random access parameters and with frame countdown element F not equal to 00₂ then it shall regard the slot 3 of the next F frames as not being valid access slots.

The following points may be noted relating to transmission and reception by the requesting DM-MS for operation with a DM-REP/GATE:

- In clauses 8.5.7.3.1 and 8.5.7.3.3, the expression "slot 3 of frames 2, 5, 8, 11, 14 and 17" refers to slot and frame numbering on the slave link. Also, the slots and frames defined by the "requests bitmap" refer to slot and frame numbering on the slave link.
- In clause 8.5.7.3.4, the references to monitoring slot 1 and slot 3 of the following frames for a response refer to slot and frame numbering on the slave link.

8.5.8 Procedures for sending messages during registration phase

NOTE: The gateway announces a registration phase by sending the gateway presence signal with the "channel state" element set to 11₂.

8.5.8.1 Procedures for registering DM-MS during registration phase

8.5.8.1.1 Preparing for registration access

The DM-MS shall only make one registration access attempt at a time, per DM channel. A registration access attempt refers to the period from receipt of the DMA-UNITDATA request primitive from layer 3 until a response is received or the procedure is abandoned.

8.5.8.1.2 First transmission of solicited registration request

The DM-MAC shall choose an integer J randomly from the range 1 to 2^M (using a uniform distribution) and shall transmit the request in the J 'th valid access slot. The value of M is the access parameter received in the most recent gateway presence signal.

The request shall be sent in a DSB using the DMAC-SYNC PDU.

8.5.8.1.3 Valid access slots

The "valid access slots" within a multiframe during a registration phase, as used in clauses 8.5.8.1.2 and 8.5.8.1.5, are as follows:

- slot 3 of frames 1, 2, 4, 5, 7, 8, 9, 10, 11, 13, 14, 15, 16 and 17.

8.5.8.1.4 Waiting for response

After sending a request, the DM-MAC shall wait for a valid response from the gateway. When sending the DM-GREGISTER REQUEST message, the DM-MS includes its own address or pseudo SSI as the layer 2 source address and does not include a destination address. In a response it then expects to see its own address or pseudo SSI as the layer 2 destination address and no source address. Both the request and the response contain the 10-bit gateway address.

The DM-MAC shall look for the response in slot 1 of the following frames. The first slot in which the response may be received is slot 1 of the first frame following the request.

Valid response message types are DM-GREGISTER ACCEPT or DM-GREGISTER REJECT.

On receipt of a valid response to the registration message, the DM-MAC shall report the success of the registration access procedure to layer 3 using the DMA-REPORT indication primitive. It shall also deliver the received message to layer 3 using the DMA-UNITDATA indication primitive.

If a response is not received within a time $DT236$ after transmission of the request, the DM-MAC shall assume that the transmission has failed. Then it shall either:

- a) abandon its registration access attempt (see clause 8.5.8.1.6); or
- b) select an access slot randomly for a retry, as defined in clause 8.5.8.1.5; however, if the DM-MAC receives a response before sending a repeat message, it shall accept the response and not retransmit.

8.5.8.1.5 Subsequent transmission of request

When the DM-MAC requires to select an access slot for a retry, it shall do so by choosing an integer K randomly from the range 1 to 2^M , using a uniform distribution, and shall transmit the request in the K 'th valid access slot (unless the registration access attempt is abandoned – see clause 8.5.8.1.6). The value of M is the access parameter received in the most recent gateway presence signal.

The DM-MAC shall then wait for a response, as defined in clause 8.5.8.1.4.

8.5.8.1.6 Abandoning registration access attempt

The DM-MAC shall cease attempting registration access if it receives a response from the gateway (as described in clause 8.5.8.1.4), or if any of the following occurs:

- a) The DM-MAC has sent the maximum permitted number of registration access transmissions without receiving a response. The maximum number of transmissions is DN239.
- b) A time DT237 has elapsed since layer 3 issued the DMA-UNITDATA request primitive.
- c) The DM-MAC receives a DM-PRE ACCEPT message with the gateway as the source but addressed to another DM-MS.
- d) The DM-MAC receives a DM-SETUP, DM-SETUP PRES, DM-SDS DATA, DM-SDS UDATA or DM-CONNECT ACK message.
- e) The DM-MAC detects the end of the registration phase, including receiving a free channel presence signal from the gateway in timeslot 3.

In cases a) to e), the failure of the registration access procedure shall be reported to layer 3 using the DMA-REPORT indication primitive.

8.5.8.2 Procedures for pre-empting DM-MS during registration phase

8.5.8.2.1 Preparing for random access

The DM-MS shall only make one random access attempt at a time, per DM channel. A random access attempt refers to the period from receipt of the DMA-UNITDATA request primitive from layer 3 until a response is received or the procedure is abandoned.

8.5.8.2.2 First transmission of pre-emption request

The DM-MAC shall transmit its pre-emption request in the first valid access slot.

The request shall be sent in a DSB using the DMAC-SYNC PDU.

8.5.8.2.3 Valid slots for pre-emption

For random access to send a pre-emption request, the "valid slots" within a multiframe during a registration phase, as used in clauses 8.5.8.2.2 and 8.5.8.2.5, are as follows:

- slot 3 of frames 1, 2, 4, 5, 7, 8, 9, 10, 11, 13, 14, 15, 16 and 17.

8.5.8.2.4 Waiting for response

After sending a request, the DM-MAC shall wait for a valid response from the gateway, containing the same addresses as in the request but with source and destination addresses reversed. It shall look for the response in slot 1 of the following frames. It shall also look for the response in each corresponding slot 3 unless this is a linearization frame. The first slot in which the response may be received is slot 1 of the first frame following the request.

- Valid response message types for the DM-PREEMPT message are DM-PRE ACCEPT or DM-REJECT.

On receipt of a valid response to the pre-emption message, the DM-MAC shall report the result of the random access procedure to layer 3 using the DMA-REPORT indication primitive. It shall also deliver the received message to layer 3 using the DMA-UNITDATA indication primitive.

If a response is not received within a time DT238 after transmission of the request, the DM-MAC shall assume that the transmission has failed. Then it shall either:

- a) abandon its random access attempt (see clause 8.5.8.2.6); or
- b) select an access slot randomly for a retry, as defined in clause 8.5.8.2.5; however, if the DM-MAC receives a response before sending a repeat message, it shall accept the response and not retransmit.

8.5.8.2.5 Subsequent transmission of request

When the DM-MAC requires to select an access slot for a retry (the Nth transmission of the request, where $N \geq 2$), it shall choose an integer K randomly from the range 1 to 2^{N-1} using a uniform distribution, and shall transmit the request in the Kth valid access slot (unless the random access attempt is abandoned – see clause 8.5.8.2.6).

The DM-MAC shall then wait for a response, as defined in clause 8.5.8.2.4.

NOTE: Thus the first request can be sent in the first valid access slot. Then, for subsequent retries, the DM-MAC chooses randomly from 2 access opportunities, then from 4, then from 8 etc.

8.5.8.2.6 Abandoning random access attempt

The DM-MAC shall cease attempting random access if it receives a response from the gateway (as described in clause 8.5.8.2.4), or if any of the following occurs:

- a) The DM-MAC has sent the maximum permitted number of random access transmissions without receiving a response. The maximum number of transmissions is DN213 for a message with priority 00₂, 01₂ or 10₂, and DN215 for an emergency message (priority 11₂).
- b) The appropriate time has elapsed since layer 3 issued the DMA-UNITDATA request primitive. The appropriate time is DT213 for a message with priority 00₂, 01₂ or 10₂ and DT215 for an emergency message (i.e. priority 11₂).

If timer DT213 or DT215 expires while timer DT211 or DT212 is active following transmission of a request, the DM-MAC shall continue to wait for a response until timer DT211 or DT212 expires before it abandons the random access attempt.

- c) The DM-MAC receives a DM-PRE ACCEPT message with the gateway as the source but addressed to another DM-MS.
- d) The DM-MAC receives a DM-SETUP, DM-SETUP PRES, DM-SDS DATA, DM-SDS UDATA or DM-CONNECT ACK message.
- e) The DM-MAC detects the end of the registration phase, except that if this is by receiving a free channel presence signal with "registration phase terminated flag" set to 1, then the DM-MS shall cease sending requests but should continue to wait for a response until the end of the frame countdown.
- f) The user indicates that the random access attempt is to be abandoned.

In cases a) to e), the failure of the random access procedure for the pre-emption request shall be reported to layer 3 using the DMA-REPORT indication primitive.

NOTE: In cases a) to e), the DM-MAC reports failure of the transmission by layer 2. Layer 3 may then decide to issue a further DMA-UNITDATA request. For example, in case e), it may attempt to set up a call directly e.g. sending DM-GSETUP on the free channel.

8.6 MAC procedures in traffic mode

8.6.1 Introduction

EN 300 396-3 [3], clause 8.6.1 shall apply.

NOTE: For operation with a DM-REP/GATE, references in EN 300 396-3 [3], clause 8.6 to transmission by the master DM-MAC in slot 1 of a particular frame refer to the slot and frame numbering on the master link. References to reception by a slave DM-MAC in slot 1 of a particular frame refer to the slot and frame numbering on the slave link, except in the case of a DM-MAC that is monitoring the master link, in which case they refer to slot and frame numbering on the master link.

8.6.2 Criteria for transmission and reception of traffic

EN 300 396-3 [3], clause 8.6.2 shall apply, with the following additional procedure.

After starting to receive traffic, a slave DM-MAC may remain in traffic mode, processing TCH and STCH received in slot 1 of frames 1 to 17, until one of cases 1) to 5) occurs or one of the following cases 6) or 7) occurs:

- 6) it receives a presence signal from the gateway, indicating that the channel is reserved;
- 7) it receives a presence signal from the gateway, indicating that the channel is free.

In case 6), the DM-MAC shall report to the higher layers that the channel is now in reservation (using the DMC-REPORT indication primitive). In case 7), the DM-MAC shall report to the higher layers that the call has been lost.

8.6.3 Change of U-plane mode

8.6.3.1 Call set-up by DM-MS

At call set-up (or for a call continuation), after the appropriate message exchange with the gateway, the DMCC issues a DM-SETUP message. The DM-MAC shall then become master and shall send the message the appropriate number of times using the frame countdown mechanism to indicate the number of frames in which the message is being repeated. The DM-MAC shall then switch to traffic mode:

- If operating with a DM-GATE, the DM-MAC shall switch to traffic mode in the frame following the frame with "frame countdown" element set to 0. It shall start sending traffic (TCH and/or STCH) in slot 1 of that frame (if it is in the range 1 to 17) or otherwise in slot 1 of frame 1.
- If operating with a DM-REP/GATE, and if the frame containing the DM-MS's final transmission of the DM-SETUP message was master link frame X, then the DM-MAC shall start sending traffic (TCH and/or STCH) in slot 1 of master link frame $Y = (X + DN232) \bmod 18 + 1$ (if Y is in the range 1 to 17) or otherwise in slot 1 of master link frame 1.

NOTE: DN232 is the number of frames in which the DM-REP/GATE transmits the DM-SETUP message on the slave link. For example, if $DN232 = 2$, and if the master DM-MAC sends its final DM-SETUP in master link frame 18, then it starts transmitting traffic in slot 1 of master link frame 3.

For correct operation of air interface encryption of TCH and STCH, it is essential that the master DM-MAC assumes the same value of DN232 as the DM-REP/GATE.

8.6.3.2 Incoming call set-up

8.6.3.2.1 Incoming call set-up without presence check

For operation with a DM-GATE, the DM-MAC procedure on receipt of a DM-SETUP message for one of its addresses shall be as defined in EN 300 396-3 [3], clause 8.6.3.1.2. I.e. for a DM-SETUP message received in frame X and with "frame countdown" element set to F, and if the DMCC issues a DMC-CONFIGURE request primitive, the slave DM-MAC shall assume that traffic will start in slot 1 of frame $Y = (X + F) \bmod 18 + 1$ (if Y is in the range 1 to 17) or otherwise in slot 1 of frame 1.

For operation with a DM-REP/GATE, the following procedure shall apply:

- On receipt of a DM-SETUP message on the slave link for one of its addresses, with the gateway indicated as master (i.e. with "gateway generated message flag" set to 1), the slave DM-MAC shall obey the procedure defined in EN 300 396-3 [3], clause 8.6.3.1.2 without amendment. I.e. for a DM-SETUP message received in slave link frame X and with "frame countdown" element set to F, and if the DMCC issues a DMC-CONFIGURE request, the slave DM-MAC shall assume that traffic will start on the slave link in slot 1 of slave link frame $Y = (X + F) \bmod 18 + 1$ (if Y is in the range 1 to 17) or otherwise in slot 1 of slave link frame 1.

- On receipt of a DM-SETUP message on the slave link for one of its addresses, with a DM-MS indicated as master (i.e. with "gateway generated message flag" set to 0), then, if the DM-SETUP message was received in slave link frame X and with "frame countdown" element set to F , and if the DMCC issues a DMC-CONFIGURE request, the slave DM-MAC shall assume that traffic will start on the slave link in slot 1 of slave link frame $Y = (X+F+1) \bmod 18 + 1$ (if Y is in the range 1 to 17) or otherwise in slot 1 of slave link frame 1.
- On receipt of a DM-SETUP message on the master link for one of its addresses, received in master link frame X and with "frame countdown" element set to F , if the DM-MAC does not subsequently receive the DM-SETUP on the slave link in the next $F+DN232$ frames, and if the DMCC issues a DMC-CONFIGURE request primitive, a monitoring slave DM-MAC shall assume that traffic will start on the master link in slot 1 of master link frame $Y = (X+F+DN232) \bmod 18 + 1$ (if Y is in the range 1 to 17) or otherwise in slot 1 of master link frame 1.

NOTE: A monitoring slave DM-MAC that has not received a presence signal from the DM-REP/GATE and assumes a different value of DN232 to the DM-REP/GATE will not correctly receive encrypted traffic.

8.6.3.2.2 Incoming call set-up with presence check

After receiving a DM-SETUP PRES message from a gateway, the addressed slave DM-MS sends DM-CONNECT or DM-DISCONNECT; refer to clause 6. This message shall be sent the appropriate number of times. After sending DM-CONNECT, the DM-MAC procedure on receipt of a DM-CONNECT ACK message for the call shall be as defined in EN 300 396-3 [3], clause 8.6.3.2.2. I.e. for a DM-CONNECT ACK message received in frame X and with "frame countdown" element set to F , the slave DM-MAC shall assume that traffic will start in slot 1 of frame $Y = (X+F) \bmod 18 + 1$ (if Y is in the range 1 to 17) or otherwise in slot 1 of frame 1. (For operation with a DM-REP/GATE, this refers to the slot and frame numbering on the slave link.)

8.6.3.3 Late entry

EN 300 396-3 [3], clause 8.6.3.3 shall apply.

8.6.3.4 End of traffic transmission

8.6.3.4.1 Master DM-MS

EN 300 396-3 [3], clause 8.6.3.4.1 shall apply with the following addition.

If a master DM-MAC sends DM-TX CEASED or DM-RELEASE in slot 1 of a frame then it shall send the message also in slot 3 of that frame – unless a DM-PRE ACCEPT takes precedence or this is a linearization frame.

8.6.3.4.2 Slave DM-MS

EN 300 396-3 [3], clause 8.6.3.4.2 shall apply.

8.6.4 Exchange of information at the DMD-SAP

EN 300 396-3 [3], clause 8.6.4 shall apply.

8.6.5 Stealing from circuit mode capacity

EN 300 396-3 [3], clause 8.6.5 shall apply.

9 Gateway layer 3 call control procedures

9.1 Introduction

This clause describes the layer 3 call control procedures conducted by a DM gateway operating with a TETRA TMO compliant SwMI.

Layer 3 of the gateway is responsible for conducting the necessary protocol conversion between the TETRA DM and TMO air interfaces; a model of the gateway call control protocol stack is shown in figure 16. This clause describes only that part of the layer 3 of the gateway which handles the TMO PDUs received from or sent to the TMO MLE through the LCMC-SAP and the call control DMO PDUs received from or sent to the DM layer 2 (the data link layer) through the GMA-SAP. Clause 10 describes the layer 3 mobility management protocol for a gateway.

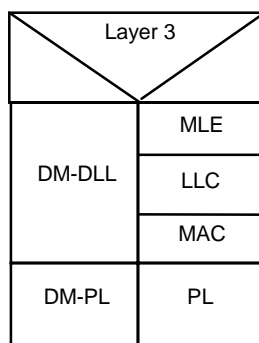

Figure 16: Gateway C-plane protocol stack

9.2 Gateway call control states

Only the main TM and DM layer 3 states are described in this clause. The actual state transitions are detailed in the later clauses.

9.2.1 Gateway TMO call control states

9.2.1.1 IDLE

This is the normal state when no calls exist and indicates that the gateway is available to handle a call set-up. This is the TMO state that the gateway shall enter following successful registration to the SwMI.

9.2.1.2 MO-CALL-SETUP

This state exists when a gateway originated TMO call set-up has been initiated and the call has not yet been established.

9.2.1.3 MT-CALL-SETUP

This state exists during a TMO call set-up where the gateway is the TMO call termination.

9.2.1.4 CALL ACTIVE

This state exists when the call has been established.

9.2.1.5 CALL DISCONNECT

This state exists when an established call is in the progress of disconnecting on TMO.

9.2.1.6 WAIT

This state exists if there is a temporary interruption to the call.

9.2.2 Gateway DM call control states

9.2.2.1 IDLE

This is the normal state when no calls exist and indicates that the gateway is available to handle a circuit mode call or short data. This is the DM state that the gateway shall enter after initial start-up.

9.2.2.2 CALL SETUP NORMAL ORIGINATING

This state exists when a gateway is the originating station for a DM call set-up from TMO which has been initiated on DM without presence check and the call has not yet been established.

9.2.2.3 CALL SETUP PRES_CHECK ORIGINATING

This state exists when a gateway is the originating station for an individual DM call set-up from TMO which has been initiated on DM with presence check and has not yet been established.

9.2.2.4 CALL SETUP TERMINATING

This state exists when a gateway is the terminating station for a DM call set-up which has been initiated by a DM-MS, and the call has not yet been established.

9.2.2.5 PRE-EMPTION

This state exists when a gateway has originated the DM pre-emption procedure.

9.2.2.6 CALL ACTIVE TX OCCUPATION

This state exists when a call has been established and the gateway is transmitting circuit mode traffic over the Ud interface.

9.2.2.7 CALL ACTIVE TX RESERVATION

This state exists when a call has been established and the traffic transmission on the channel has ceased but the DM reservation time has not expired.

9.2.2.8 CALL ACTIVE RX OCCUPATION

This state exists when a call has been established and the gateway is receiving circuit mode traffic over the Ud interface.

9.2.2.9 WAIT RSP OCCUPATION

This state exists when a call has been established and the gateway has initiated DM pre-emption (for call continuation) while it is receiving traffic.

9.2.2.10 ACK'D SHORT DATA INITIATED

This state exists when the gateway has initiated an acknowledged short data transfer over the Ud interface.

9.2.2.11 UNACK'D SHORT DATA INITIATED

This state exists when the gateway has initiated an unacknowledged short data transfer over the Ud interface.

9.3 Layer 3 circuit mode call control procedures

This clause describes the gateway layer 3 circuit mode call control procedures for point-to-point and point-to-multipoint calls.

NOTE 1: The gateway provides the interface between TETRA TMO and DMO. On the TMO side its operation is similar to a normal TM-MS. Therefore it is required to comply with EN 300 392-2 [5], clause 14. Not all the TMO protocol error conditions have been covered in this clause. Gateway designers should refer to EN 300 392-2 [5], clause 14 for the full detail.

NOTE 2: The procedures in this clause (and in clause 10) refer to timers used in the gateway's layer 3 protocol. There are two types of gateway layer 3 timer: Txxx and Dtyyy. The Txxx timers refer to the TMO protocol and are defined in EN 300 392-2 [5], clause 14. The DT timers refer to the DM protocol and are defined in annex A. In some cases xxx may be numerically equal to yyy; however the timers are distinct.

9.3.1 Incoming call set-up from TMO

The following procedures assume that the gateway is in the IDLE state prior to receiving the incoming signalling.

The procedure for handling an incoming call from TMO begins following the successful reception of a D-SETUP PDU from the TMO SwMI.

If the incoming TMO call request is not valid the gateway shall remain in the IDLE state and, in the case of an individual call, shall also send a U-DISCONNECT PDU to the SwMI.

Otherwise the gateway shall proceed as described in clause 9.3.1.1 for an incoming individual call or clause 9.3.1.2 for an incoming group call.

The D-SETUP PDU from the SwMI indicates whether the call request is for an individual call or group call and the type of service requested (e.g. voice or data).

The present document supports the following services over DMO interface Ud:

- speech (clear or encrypted);
- circuit mode unprotected services (clear or encrypted):
 - 7,2 kbit/s;
- circuit mode protected services (clear or encrypted):
 - 2,4 kbit/s;
 - 4,8 kbit/s;
- interleaving depths permitted for circuit mode protected services:
 - N = 1, 4 and 8.

9.3.1.1 Incoming individual call set-up from TMO

Following the receipt of an incoming TMO call set-up message and in the case where the DM channel is currently not free, the gateway shall decide whether pre-emption or termination of a registration phase is valid and if so may employ the DM pre-emption procedures appropriate for the current ongoing call or the termination of registration phase procedure. If pre-emption is not valid or the gateway wants the registration phase to continue, then the gateway shall send a U-DISCONNECT PDU to the SwMI and remain in state IDLE.

Otherwise, when the incoming TMO individual call request is valid and the DM channel is free, the gateway shall map and send the D-SETUP PDU contents in a DM-SETUP PRES PDU and enter TMO state MT-CALL-SETUP and DM state CALL SETUP PRES_CHECK ORIGINATING.

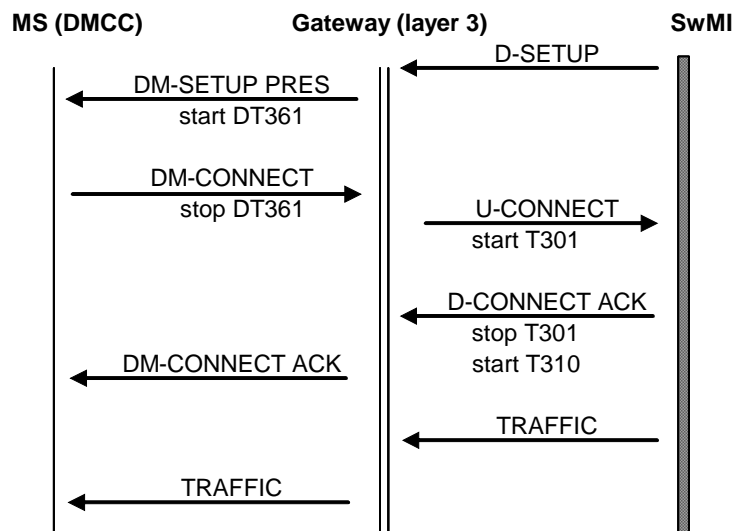

Figure 17: Incoming individual call from TMO

If the gateway receives a GMA-REPORT indication reporting failure to transmit the DM-SETUP PRES PDU over the Ud interface because the DM channel has become busy then the gateway shall either:

- send a U-DISCONNECT PDU to the SwMI and return to state IDLE; or
- for a sufficiently high priority call, invoke the DM pre-emption procedures appropriate to the ongoing call.

Otherwise, on receiving a GMA-REPORT indication reporting that the DM-SETUP PRES PDU has been transmitted the appropriate number of times, the gateway shall start timer DT361 and wait for a response from the called DM-MS:

- If timer DT361 expires then the gateway shall send a DM-RELEASE PDU and attempt to resend the DM-SETUP PRES PDU again up to a maximum of DN361 times. If the gateway is unsuccessful in sending the DM-SETUP PRES PDU then it shall send a U-DISCONNECT PDU to the SwMI and return to state IDLE.
- If the gateway receives a DM-DISCONNECT PDU rejecting the call request then it shall stop timer DT361, send a DM-RELEASE PDU to the called DM-MS, send a U-DISCONNECT PDU to the SwMI and return to state IDLE.
- If the gateway receives a DM-CONNECT PDU accepting the requested service or offering a reduced service then it shall stop timer DT361, map and send the DM-CONNECT PDU elements in a U-CONNECT PDU and start timer T301.
- In the case where the original D-SETUP PDU contained:
- An on/off hook signalling request, the gateway shall set the hook method selection element value to "no hook signalling" in the U-CONNECT PDU;
 - a request to support a duplex call, the gateway shall only offer a simplex service by setting the simplex/duplex selection element value to "simplex requested" in the U-CONNECT PDU;
 - a request to support a multi-slot call, the gateway shall only offer a single-slot service by setting the slots per frame sub-element value to "one slot" in the U-CONNECT PDU.

If timer T301 expires then the gateway shall:

- send a DM-RELEASE PDU to the called DM-MS indicating TMO call set-up failure;
- send a U-DISCONNECT PDU to the SwMI; and
- return to state IDLE.

During the call set-up phase, after the transmission of a U-CONNECT PDU by the gateway, the SwMI may send a D-INFO PDU containing a T301 value to prolong the call set-up time. If the gateway receives a D-INFO PDU extending the call set-up time then it shall start timer T301 using the specified value and send the DM-SETUP PRES PDU again.

NOTE 1: The gateway may re-send the DM-SETUP PRES PDU to the called DM-MS also at other times during the call set-up phase, if it needs to extend the DM call set-up time (DM-MS timer DT307).

The SwMI may also send either a D-RELEASE PDU or a D-DISCONNECT PDU in response to a U-CONNECT PDU. If the gateway receives either of these PDUs then it shall stop timer T301, send a DM-RELEASE PDU to the called DM-MS and return to state IDLE. (In the case of D-DISCONNECT, the gateway also sends a U-RELEASE PDU to the SwMI).

Otherwise, on receiving a D-CONNECT ACKNOWLEDGE PDU, the gateway shall:

- map and send the elements of the D-CONNECT ACKNOWLEDGE PDU in a DM-CONNECT ACK to the called DM-MS;
- enter DM state CALL ACTIVE TX OCCUPATION and TMO state CALL ACTIVE;
- stop timer T301;
- start timer T310; and
- issue CONFIGURE requests for TM and DM lower layer traffic configuration.

NOTE 2: In the case where the incoming TMO call is from an inter-MNI address or an external source, the gateway may provide the called DM-MS with the talking party TSI or the external number by sending it in a DM-INFO PDU during the traffic transmission, using the stealing channel mechanism.

The D-CONNECT ACKNOWLEDGE PDU sent by the SwMI contains an indication as to which party is permitted to transmit. For an incoming TMO call in DM gateway operation, this is recommended to be the TMO side. If it is not then one of the following procedures applies:

- If the D-CONNECT ACKNOWLEDGE PDU indicates that the called DM-MS is expected to transmit first in the call then the gateway shall immediately send a U-TX CEASED PDU to the SwMI (and, on receiving a D-TX CEASED PDU or a REPORT indication of successful or unsuccessful transmission of the U-TX CEASED PDU by the TM lower layers, shall then issue a CONFIGURE request to the TM lower layers to switch the U-plane off). Also it shall, following the transmission of the DM-CONNECT ACK PDU, send a DM-TX CEASED PDU to the called DM-MS and enter DM state CALL ACTIVE TX RESERVATION (see figure 18).
- If the D-CONNECT ACKNOWLEDGE PDU indicates that transmit permission is not currently granted to any party within the call then the gateway shall, following the transmission of the DM-CONNECT ACK PDU, send a DM-TX CEASED PDU to the called DM-MS and enter DM state CALL ACTIVE TX RESERVATION.

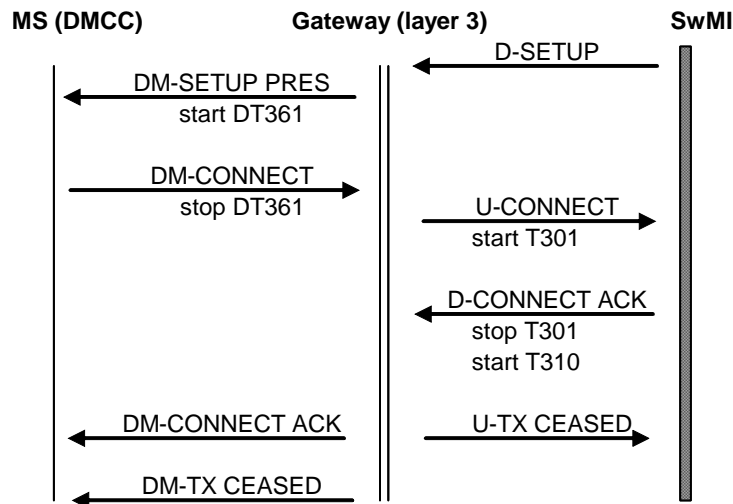

Figure 18: Incoming TMO individual call where TX permission granted to DM-MS

If the gateway during call set-up cannot continue to support the call for reasons other than those stated above then the gateway shall reject the call set-up request by sending a U-DISCONNECT PDU to the SwMI and shall send a DM-RELEASE PDU to the called DM-MS and return to state IDLE.

9.3.1.2 Incoming group call set-up from TMO

NOTE 1: Acknowledged group calls are not supported in the present document.

Following the receipt of an incoming TMO call set-up message for an appropriate group address and in the case where the DM channel is currently not free, the gateway shall decide whether pre-emption or termination of a registration phase is valid and if so may employ the DM pre-emption procedures appropriate to the ongoing call or the termination of registration phase procedure. If pre-emption is not valid or the gateway wants the registration phase to continue, then the gateway shall discard the call set-up message and remain in state IDLE.

Otherwise, when an incoming TMO group call request is valid and the DM channel is free, the gateway shall:

- map and send the elements of the D-SETUP PDU in a DM-SETUP PDU;
- enter TMO state CALL ACTIVE;
- start timer T310;
- issue a CONFIGURE request for TM lower layer traffic configuration; and
- enter DM state CALL SETUP NORMAL ORIGINATING.

After sending the DM-SETUP PDU the gateway shall wait for a GMA-REPORT indication reporting on the progress of the transmission of the message:

- If the gateway receives a GMA-REPORT indication reporting failure to transmit the DM-SETUP PDU because the DM channel has become busy then it shall either:
 - stop timer T310 and return to state IDLE; or
 - for a sufficiently high priority call, invoke the DM pre-emption procedures appropriate to the ongoing call.
- Otherwise, on receiving a GMA-REPORT indication reporting that the DM-SETUP PDU has been transmitted, the gateway shall:
 - enter DM state CALL ACTIVE TX OCCUPATION; and
 - issue a GMC-CONFIGURE request for DM lower layer traffic configuration.

NOTE 2: In the case where the incoming TMO call is from an inter-MNI address or an external source, the gateway may provide the called DM-MS with the talking party TSI or the external number by sending it in a DM-INFO PDU during the traffic transmission, using the stealing channel mechanism.

If the transmission grant element in the D-SETUP PDU indicates that transmit permission has not been granted to any party then the gateway shall, following the transmission of the DM-SETUP PDU, send a DM-TX CEASED PDU to the called group and enter DM state CALL ACTIVE TX RESERVATION.

9.3.1.3 Sending of DM-OCCUPIED PDU by master gateway

At the start of DM circuit mode traffic transmission, the gateway layer 3 shall issue a GMA-UNITDATA request to layer 2 containing a DM-OCCUPIED PDU. While it is transmitting circuit mode traffic, layer 2 sends the DM-OCCUPIED PDU at intervals (see clause 13). This PDU is similar to the DM-SETUP PDU and enables late entry by DM-MSs that did not receive the initial set-up signalling.

9.3.2 Outgoing call set-up to TMO

The following procedures assume that the gateway is in state IDLE prior to receiving a signalling message from a DM-MS over the Ud interface.

9.3.2.1 Outgoing call to TMO set-up procedures

The gateway may begin outgoing TMO call procedures, either for an individual call or a group call to an appropriate group address, following the successful receipt of a valid DM-GSETUP PDU from a DM-MS.

In the case where a DM-GSETUP PDU was not fully received, the gateway shall send a DM-GACK PDU indicating this to the calling DM-MS.

If the request is invalid including if the gateway is unable to accept the incoming call request from the DM-MS for any reason then it shall reject the call by sending a DM-RELEASE PDU to the calling DM-MS and remain in state IDLE.

Otherwise, if the set-up request is valid, the gateway shall:

- map and send the DM-GSETUP PDU elements in a U-SETUP PDU;
- enter DM state CALL SETUP TERMINATING and TMO state MO-CALL-SETUP; and
- start timer T303.

Also, it may send a DM-GACK PDU to the calling DM-MS indicating successful receipt of set-up request.

NOTE 1: In normal operation a gateway should typically request permission to transmit by setting the request to transmit bit accordingly in the U-SETUP PDU and request direct set-up signalling for all call set-up requests to the SwMI.

The progress of the U-SETUP PDU transmission may be reported by the TM lower layers in one or more REPORT indications. If the U-SETUP PDU transfer has failed then the gateway shall:

- stop timer T303;
- send a DM-RELEASE PDU to the calling DM-MS indicating TMO call set-up failure; and
- return to state IDLE.

If timer T303 expires then the gateway shall:

- send a DM-RELEASE PDU to the calling DM-MS indicating TMO call set-up failure;
- send a U-DISCONNECT PDU to the SwMI; and
- return to state IDLE.

In some cases the SwMI may respond to a U-SETUP PDU with a D-CALL PROCEEDING PDU (or, for an individual call, possibly a D-ALERT PDU) indicating that the SwMI has received all information concerning the call set-up. If the D-CALL PROCEEDING PDU (or D-ALERT PDU) proposes a service change the DMO does not support or that the gateway cannot support (see note 3) then the gateway should stop timer T303, send a DM-RELEASE PDU to the calling DM-MS, send a U-DISCONNECT PDU to the SwMI and return to state IDLE. Otherwise the gateway may send a DM-GACK PDU to the calling DM-MS indicating that the call request was successfully received. On reception of a D-CALL PROCEEDING (or D-ALERT) PDU the gateway shall stop timer T303 and start timer T302 using the specified value.

During the call set-up phase, the SwMI may send a D-INFO PDU containing a T302 value to prolong the call set-up time. If the gateway receives a D-INFO PDU indicating an extension to the call set-up time the gateway shall start timer T302 using the specified value and send a DM-GACK PDU to the calling DM-MS.

NOTE 2: The gateway may send the DM-GACK PDU to the calling DM-MS also at other times during the call set-up phase, if it needs to extend the DM call set-up time (DM-MS timer DT302).

If timer T302 expires the gateway shall:

- send a DM-RELEASE PDU to the calling DM-MS indicating TMO call set-up failure;
- send a U-DISCONNECT PDU to the SwMI; and
- return to state IDLE.

If the gateway receives a D-RELEASE (or D-DISCONNECT) PDU from the SwMI rejecting the call request then it shall stop timer T302 or T303, send a DM-RELEASE PDU to the calling DM-MS and return to state IDLE. (In the case of D-DISCONNECT, the gateway also sends a U-RELEASE PDU to the SwMI).

If the gateway receives a D-CONNECT PDU from the SwMI proposing a changed service, the gateway may accept or reject the proposed change. If it is a service that DMO does not support (e.g. duplex call or multi-slot call), or a change the gateway cannot support, then the gateway should stop timer T302 or T303, send a DM-RELEASE PDU to the calling DM-MS, send a U-DISCONNECT PDU to the SwMI and return to state IDLE.

NOTE 3: A change to on/off hook signalling should be accepted because this may be all that the SwMI or called TM-MS can support. A change from point-to-multipoint to point-to-point may be accepted, in which case the gateway continues to support the group call on the DMO side and a point-to-point call on the TMO side. A change from point-to-point to point-to-multipoint may be accepted, in which case the gateway continues to support the individual call on the DMO side and supports a group call on the TMO side using the temporary address provided as the destination group address for the group call. Precisely how such changes are supported is outside the scope of the present document.

If the gateway receives an acceptable D-CONNECT PDU from the SwMI then it shall perform the appropriate procedure 1), 2) or 3):

- 1) If the D-CONNECT PDU indicates that transmission permission has been given to another party rather than the calling DM-MS then the gateway shall:
 - stop timer T302 or T303;
 - map and send the elements of the D-CONNECT PDU in a DM-SETUP PDU;
 - enter DM state CALL ACTIVE TX OCCUPATION and TMO state CALL ACTIVE;
 - start timer T310; and
 - issue CONFIGURE requests for TM and DM lower layer traffic configuration.
- 2) If the D-CONNECT PDU indicates that transmit permission has not been granted to any party then the gateway shall:
 - stop timer T302 or T303;
 - enter TMO state CALL ACTIVE;
 - start timer T310;

- issue a CONFIGURE request for TM lower layer traffic configuration; and
 - send a DM-SETUP PDU followed by a DM-TX CEASED PDU and then enter DM state CALL ACTIVE TX RESERVATION.
- 3) Otherwise, if the D-CONNECT PDU indicates that the gateway has been assigned transmit permission then the gateway shall:
- stop timer T302 or T303;
 - map and send the D-CONNECT PDU elements in a DM-GCONNECT PDU using the same DM request label value contained in the original DM-GSETUP PDU;
 - enter TMO state CALL ACTIVE;
 - start timers T310, T311 and DT363; and
 - issue a CONFIGURE request for TM lower layer traffic configuration.

The gateway shall then wait to receive signalling from the calling DM-MS:

- If timer DT363 expires or the gateway receives a DM-RELEASE PDU from the calling DM-MS then it shall:
 - stop timers T310 and T311;
 - send a U-DISCONNECT PDU to the SwMI and start timer T308 (and, on receiving a D-RELEASE PDU or a REPORT indication of failed PDU transfer or on expiry of timer T308, shall issue a CONFIGURE request to the TM lower layers to switch the U-plane off);
 - issue a GMC-CONFIGURE request to indicate idle operation due to DM layer 3 timer expiry; and
 - return to state IDLE.
- Otherwise, on receiving a DM-SETUP PDU containing the same destination address as the DM-GSETUP called party address and basic service information consistent with the earlier signalling, the gateway shall:
 - stop timer DT363;
 - enter DM state CALL ACTIVE RX OCCUPATION; and
 - issue a GMC-CONFIGURE request for DM lower layer traffic configuration.

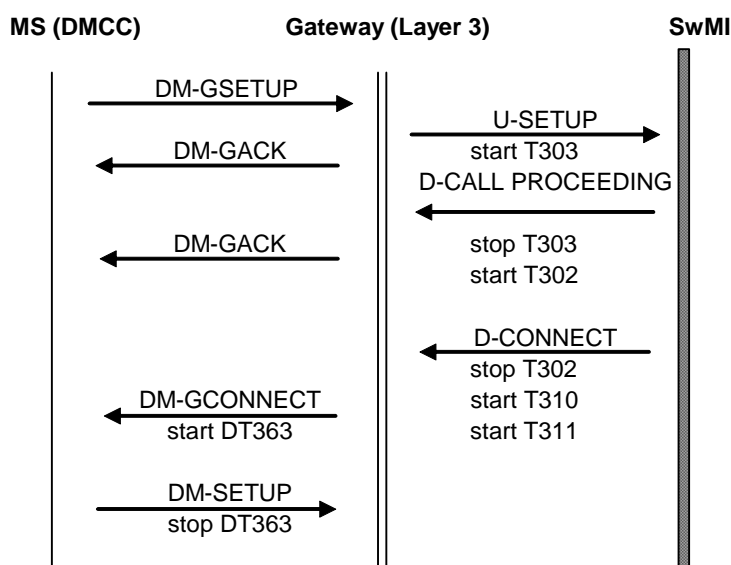

Figure 19: Outgoing call to TMO

For a group call set-up: if the gateway receives a D-SETUP PDU addressed to the group after reception of D-CALL PROCEEDING (and optionally D-INFO), if the call identifier in the D-SETUP PDU is the same as the call identifier in the D-CALL PROCEEDING PDU and the calling party address in the D-SETUP PDU does not contain either the gateway's individual address or the calling DM-MS's address, then the gateway shall follow procedure 1) or 2) above as appropriate. The gateway shall ignore the D-SETUP PDU if the calling party address is the gateway's individual address or the calling DM-MS's address.

9.3.2.2 Colliding call set-up signalling over the TMO air interface (Um)

Call collisions can occur over the TMO air interface (Um) when both SwMI and gateway simultaneously send a D-SETUP and U-SETUP PDU. Two call set-ups are colliding when a D-SETUP PDU is received within the window where the gateway waits for a call identifier from the SwMI after a U-SETUP PDU has been issued.

If a collision occurs then, in the case where the incoming D-SETUP PDU has a higher call priority than the outgoing U-SETUP PDU, the gateway shall accept the call using the procedures described in clause 9.3.1.1 in the case of an individual call or clause 9.3.1.2 in the case of a group call and shall send a CANCEL request to the TM lower layers to cancel the sending of the U-SETUP PDU. If the lower layers indicate that the PDU has already been completely sent, then the gateway shall send a U-DISCONNECT PDU for its own call set-up.

In the case where the U-SETUP PDU contains a higher call priority than the D-SETUP PDU then, if the incoming TMO call is an individual call, the gateway shall respond to the incoming call with a U-DISCONNECT PDU, with a disconnect cause set appropriately.

For a group call set-up: if the colliding calls are call set-up attempts for the same group and the requested basic services are compatible and the TM lower layers have not indicated successful transmission of the U-SETUP PDU then the gateway shall send a CANCEL request to the TM lower layers to cancel sending of the U-SETUP PDU. If cancellation is successful, the gateway shall accept the incoming call. If cancellation is unsuccessful or if the TM lower layers have indicated successful transmission of the U-SETUP PDU, the gateway shall continue its own call set-up and wait for a D-CALL PROCEEDING and/or D-CONNECT PDU (and/or D-RELEASE PDU).

9.3.2.3 Unsuccessful call set-up to TMO

Unsuccessful call set-up shall refer specifically to those instances where the gateway TMO circuit mode connection was not successfully established. It shall not refer to call disconnection or call rejection.

When the gateway receives a REPORT indication indicating that the lower layers have not been successful (failed transfer) in the sending of any of the call set-up PDUs, the gateway shall send a DM-RELEASE PDU to the calling DM-MS indicating TMO call set-up failure and return to state IDLE.

9.3.3 Call maintenance procedures

The following call maintenance procedures shall only apply when a gateway is in a CALL ACTIVE state.

9.3.3.1 End of transmission

The end of a transmission shall be indicated to the gateway by receiving either a DM-TX CEASED PDU from the current master DM-MS or a D-TX CEASED PDU from the SwMI.

9.3.3.1.1 Reception of DM-TX CEASED PDU from current master DM-MS

In the case where a gateway is currently a slave on the DM channel and it receives a DM-TX CEASED PDU from the current master DM-MS indicating either a normal end of transmission or pre-emptive use of resource (see note) it shall:

- map and send the DM-TX CEASED PDU elements in a U-TX CEASED PDU with the stealing permission set to "immediate stealing" and the stealing repeats flag set;
- enter DM state CALL ACTIVE TX RESERVATION; and
- stop timer T311.

On receiving a D-TX CEASED PDU from the SwMI (or a REPORT indication of successful or unsuccessful transmission of the U-TX CEASED PDU by the TM lower layers), the gateway shall then issue a CONFIGURE request to the TM lower layers to switch the U-plane off.

NOTE: In the case where the gateway is slave on the DM channel, indication that the current master DM-MS has accepted a pre-emption request is through the gateway receiving the DM-TX CEASED PDU.

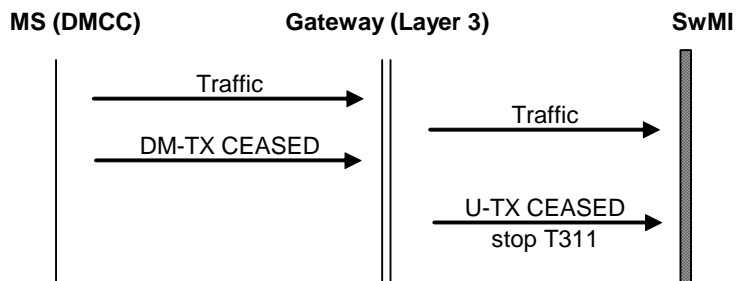

Figure 20: End of traffic transmission by master DM-MS

9.3.3.1.2 Reception of D-TX CEASED PDU from TMO

If a gateway which is currently operating as master during DM channel occupation receives a D-TX CEASED PDU from the SwMI then it shall:

- map and send the D-TX CEASED PDU elements in a DM-TX CEASED PDU;
- enter DM state CALL ACTIVE TX RESERVATION; and
- issue a CONFIGURE request to the TM lower layers to switch the U-plane off.

9.3.3.1.3 Gateway initiated DM-TX CEASED

A gateway in DM state CALL ACTIVE TX OCCUPATION may need to temporarily stop the ongoing DM transmission because, for example, a change to the current DM channel timing is required or a change of TMO transmitting party has taken place. In this case, it shall send a DM-TX CEASED PDU (to which layer 2 may add timing adjustment information, see clause 13.4.7.16). Then, if the TMO call transaction is still in progress, the gateway shall:

- send a DM-SETUP PDU (which may contain new calling party information if appropriate);
- return to DM state CALL ACTIVE TX OCCUPATION; and
- issue a GMC-CONFIGURE request for DM lower layer traffic configuration.

Otherwise, if the TMO call transaction is no longer in progress, the gateway shall enter state CALL ACTIVE TX RESERVATION.

9.3.3.2 Reception of D-TX INTERRUPT from TMO

During a call transmission a gateway may receive a D-TX INTERRUPT PDU from the SwMI.

If the gateway is currently in DM state CALL ACTIVE TX OCCUPATION, it shall send a DM-TX CEASED PDU. Then:

- in the case of a D-TX INTERRUPT PDU indicating that transmission permission has not been assigned to any party, the gateway shall issue a CONFIGURE request to the TM lower layers to switch the U-plane off and enter DM state CALL ACTIVE TX RESERVATION; or
- in the case of a D-TX INTERRUPT PDU indicating that transmit permission has been assigned to another party, the gateway shall:
 - map and send the elements of the D-TX INTERRUPT PDU in a DM-SETUP PDU;
 - return to DM state CALL ACTIVE TX OCCUPATION; and

- issue CONFIGURE requests for TM and DM lower layer traffic configuration.

NOTE: In the case where the incoming transmission interrupt is from an inter-MNI address or an external source, the gateway may provide the called DM-MS with the talking party TSI or the external number by sending it in a DM-INFO PDU during the traffic transmission, using the stealing channel mechanism.

If the gateway is currently in DM state CALL ACTIVE RX OCCUPATION, it shall follow the pre-emption procedure described in clause 9.3.4.2.1.

9.3.3.3 Incoming TMO transmission during DM channel reservation

When a gateway in DM state CALL ACTIVE TX RESERVATION receives a D-TX GRANTED PDU for continuation of the ongoing call by another party it shall:

- map and send the elements of the D-TX GRANTED PDU in a DM-SETUP PDU;
- enter DM state CALL ACTIVE TX OCCUPATION; and
- issue CONFIGURE requests for TM and DM lower layer traffic configuration.

NOTE: In the case where the incoming TMO transmission is from an inter-MNI address or an external source, the gateway may provide the called DM-MS with the talking party TSI or the external number by sending it in a DM-INFO PDU during the traffic transmission, using the stealing channel mechanism.

9.3.3.4 Reception of a DM request to transmit during DM channel reservation

When a gateway is in DM state CALL ACTIVE TX RESERVATION and receives either a DM-GTX REQUEST, DM-TX REQUEST, DM-GPREEMPT or DM-PREEMPT PDU from a DM-MS, it shall check the validity of the request. In the case of a DM-PREEMPT message for a new call validity some checks are defined in clause 9.3.4.1. If the request is not valid, the gateway may send to the requesting DM-MS:

- a DM-GREJECT PDU with reject cause set to "request rejected by gateway" (in the case where it had received a DM-GTX REQUEST or DM-GPREEMPT PDU); or
- a DM-REJECT PDU with reject cause set to "request rejected by gateway" (in the case where it had received a DM-TX REQUEST or DM-PREEMPT PDU),

and shall remain in state CALL ACTIVE TX RESERVATION.

NOTE 1: The gateway should reject a DM-TX REQUEST or a DM-PREEMPT PDU requesting to send short data within the ongoing call if it does not support the short data service.

Otherwise, if the request is valid then:

- if it is a changeover request (i.e. DM-GTX REQUEST or DM-TX REQUEST) then the gateway shall follow the appropriate procedure described below;
- if it is a DM-GPREEMPT or a DM-PREEMPT requesting to send short data within the ongoing call (see note) then the gateway shall follow the appropriate procedure described below; or
- if it is a DM-PREEMPT for a new call then the gateway shall follow the procedure described in clause 9.3.4.1.3.

NOTE 2: The gateway may receive a DM-GPREEMPT PDU for continuation of ongoing circuit mode call or a DM-PREEMPT PDU for sending short data within the ongoing call during channel reservation. This can occur if the requesting DM-MS initiated the pre-emption procedure during the previous occupation period.

9.3.3.4.1 Response to valid DM-GTX REQUEST (or DM-GPREEMPT) PDU

If a gateway in DM state CALL ACTIVE TX RESERVATION receives a valid DM-GTX REQUEST PDU (or DM-GPREEMPT PDU), it shall map and send the elements in a U-TX-DEMAND PDU. It may also send a DM-GACK PDU to the requesting DM-MS indicating that the DM-GTX REQUEST (or DM-GPREEMPT) PDU was successfully received.

NOTE 1: When the gateway transmits a U-TX DEMAND PDU the TX demand priority element value should be mapped from the priority level given in the DM-GTX REQUEST (or DM-GPREEMPT) PDU.

NOTE 2: The gateway may send the DM-GACK PDU also at other times, if it needs to extend the requesting DM-MS's waiting time (DT309 or DT308).

The progress of the transmission of the U-TX DEMAND PDU shall be reported locally within the gateway in one or more REPORT indication primitives. If the gateway receives a REPORT indication reporting failed transmission of the U-TX DEMAND PDU then it shall send a DM-GREJECT PDU to the requesting DM-MS and remain in state CALL ACTIVE TX RESERVATION.

Otherwise the gateway shall wait for a response to the U-TX DEMAND PDU:

- If the gateway receives a D-TX GRANTED PDU indicating that the transmit request has been rejected then it shall send a DM-GREJECT PDU to the requesting DM-MS.
- If the gateway receives a D-TX GRANTED PDU indicating that transmit permission has been granted to another user, and not containing the requesting DM-MS's or gateway's individual address as the transmitting party address, then the gateway shall (see note 4):
 - map and send the elements of the D-TX GRANTED PDU in a DM-SETUP PDU;
 - enter DM state CALL ACTIVE TX OCCUPATION;
 - issue CONFIGURE requests for TM and DM lower layer traffic configuration;
 - send U-TX CEASED to the SwMI to indicate that the requesting DM-MS is no longer requesting permission to transmit (the DM-MS treats the DM-SETUP PDU as rejecting the DM-GTX REQUEST).

NOTE 3: If the D-TX GRANTED PDU indicates that transmit permission has been granted to another user and contains the requesting DM-MS's or gateway's individual address as the transmitting party address then the gateway continues to wait for a response to its U-TX DEMAND PDU.

- If the gateway receives a D-TX GRANTED PDU indicating that the transmit request has been queued then it may send a DM-GACK PDU to the requesting DM-MS.
- If the gateway receives another valid DM-GTX REQUEST (or DM-GPREEMPT) PDU from a different DM-MS, the gateway shall either reject the second request using DM-GREJECT or abort the first request by sending U-TX CEASED to the SwMI and a DM-GREJECT to the DM-MS, before performing the normal signalling for the second request.

NOTE 4: The gateway can choose which request to reject. For example the gateway might reject the first request if and only if the second request is of higher priority. The gateway does not send a U-TX DEMAND for both DM-MSs and leave it to the SwMI to decide because this could only work if DM-MS addressing is included in the TMO PDUs and this may not be the case.

- Otherwise, if the gateway receives a D-TX GRANTED PDU indicating that transmit permission has been granted to the requesting DM-MS, it shall:
 - send a DM-GTX ACCEPT PDU (or DM-GPRE ACCEPT PDU) to the requesting DM-MS;
 - enter DM state CALL SETUP TERMINATING;
 - start timers T311 and DT367; and
 - issue a CONFIGURE request for TM lower layer traffic configuration.
- The gateway shall then wait to receive signalling from the DM-MS:
 - If timer DT367 expires then the gateway shall:
 - stop timer T311;
 - send a U-TX CEASED PDU to the SwMI (and, on receiving a D-TX CEASED PDU or a REPORT indication of successful or unsuccessful transmission of the U-TX CEASED PDU by the TM lower layers, shall then issue a CONFIGURE request to the TM lower layers to switch the U-plane off);

- issue a GMC-CONFIGURE request to indicate a return to channel reservation; and
 - return to DM state CALL ACTIVE TX RESERVATION.
- Otherwise, on receiving a DM-SETUP PDU containing the same destination address as the ongoing call and basic service information consistent with the earlier signalling, the gateway shall:
- stop timer DT367;
 - enter DM state CALL ACTIVE RX OCCUPATION; and
 - issue a GMC-CONFIGURE request for DM lower layer traffic configuration.

In the case of a group call the SwMI sends two D-TX GRANTED PDUs in response to a transmit request for continuation of the call, one addressed to the group and the other individually addressed to the MS that has been given permission to transmit. If the SwMI has accepted a request to operate as a DM gateway then, when granting transmit permission to a DM-MS under that gateway, it shall send the individually addressed D-TX GRANTED ("transmission granted") PDU first or supply the transmitting party address in the group addressed D-TX GRANTED ("transmission granted to another user") or both. Thus the SwMI recommendation in EN 300 392-2 [5], clause 14.5.2.2.1, note 1 is mandatory when granting transmit permission to a DM-MS operating through a DM gateway.

NOTE 5: If the gateway has not informed the SwMI that it is operating as a DM gateway or if its request to operate as a DM gateway was not accepted, and if the gateway does not know whether the SwMI is following the recommendation in EN 300 392-2 [5], clause 14.5.2.2.1, note 1, then it should modify its behaviour as follows. If the gateway it has sent a U-TX DEMAND PDU and then receives a group addressed D-TX GRANTED PDU not containing the transmitting party address, it should wait for a few frames (continuing to look for an individually addressed D-TX GRANTED PDU) before proceeding with the DM signalling for a call transaction from TMO.

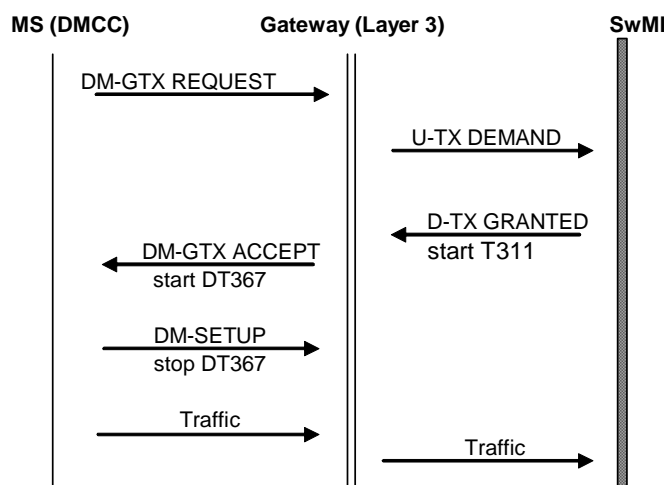

Figure 21: DM transmit request during DM channel reservation

9.3.3.4.2 Response to valid DM-TX REQUEST (or DM-PREEMPT) PDU

In the case where a gateway in DM state CALL ACTIVE TX RESERVATION receives a valid DM-TX REQUEST PDU (or a DM-PREEMPT PDU requesting to send short data within the ongoing call) it shall:

- send a DM-TX ACCEPT PDU (or a DM-PRE ACCEPT PDU) to the calling DM-MS; and
- start timer DT368.
- The gateway shall then wait to receive the short data message from the DM-MS:
 - On receiving a DM-SDS DATA or DM-SDS UDATA PDU, the gateway shall follow the procedures for reception and subsequent TMO transmission of short data described in clause 9.4.2.1.
 - On receiving a GMC-REPORT indication reporting the end of the DM SDS occupation period, the gateway shall stop timer DT368 and return to DM state CALL ACTIVE TX RESERVATION.

- If timer DT368 expires, and layer 2 has not reported that the channel is in SDS occupation, then the gateway shall:
 - issue a GMC-CONFIGURE request to indicate a return to channel reservation; and
 - return to DM state CALL ACTIVE TX RESERVATION.

9.3.3.5 TMO permission to transmit withdrawn during a call

In some instances the SwMI may decide to interrupt transmission when resources are required for another call or the SwMI requires that the call should be temporarily paused. In this case the SwMI sends a D-TX WAIT PDU.

On receiving a D-TX WAIT PDU, the gateway shall enter TMO state WAIT. Also, if the gateway is currently in DM state CALL ACTIVE TX OCCUPATION, it shall:

- send a DM-TX CEASED PDU;
- enter DM state CALL ACTIVE TX RESERVATION; and
- issue a CONFIGURE request to the TM lower layers to switch the U-plane off.

If the gateway is currently in DM state CALL ACTIVE RX OCCUPATION, it shall follow the pre-emption procedure described in clause 9.3.4.2.1.

9.3.3.6 TMO permission to continue with withdrawn call

When the SwMI has decided that a withdrawn call can continue, it sends a D-TX CONTINUE PDU.

When the gateway receives notification of the continuation of the call, it shall return to TMO state CALL ACTIVE.

The D-TX CONTINUE PDU contains an indication (the continue element) to specify whether the same transmission permission applies as at the time of the interruption.

If the continue element indicates that transmission permission is as stated before the D-TX WAIT PDU then the gateway, in the case where it was in DM state CALL ACTIVE TX OCCUPATION just prior to receiving the WAIT instruction, shall:

- send a DM-SETUP PDU;
- enter DM state CALL ACTIVE TX OCCUPATION; and
- issue CONFIGURE requests for TM and DM lower layer traffic configuration.

If the continue element indicates that transmission permission is as stated before the D-TX WAIT PDU then the gateway, in the case where it was in DM state CALL ACTIVE RX OCCUPATION just prior to receiving the WAIT instruction, shall:

- remain in DM state CALL ACTIVE TX RESERVATION;
- issue a CONFIGURE request for TM lower layer traffic configuration; and
- send a U-TX CEASED PDU to the SwMI (and, on receiving a D-TX CEASED PDU or a REPORT indication of successful or unsuccessful transmission of the U-TX CEASED PDU by the TM lower layers, shall then issue a CONFIGURE request to the TM lower layers to switch the U-plane off).

If the gateway was in DM state CALL ACTIVE TX RESERVATION just prior to receiving the WAIT instruction or if the continue element indicates that transmission permission is not as stated before the D-TX WAIT PDU then the gateway shall remain in DM state CALL ACTIVE TX RESERVATION.

If the gateway receives a D-TX GRANTED PDU when it is in TMO state WAIT then it shall return to TMO state CALL ACTIVE. If the D-TX GRANTED PDU indicates "transmission granted to another user" then the gateway shall obey the instruction in the D-TX GRANTED PDU i.e. it shall:

- send a DM-SETUP PDU;

- enter DM state CALL ACTIVE TX OCCUPATION; and
- issue CONFIGURE requests for TM and DM lower layer traffic configuration.

If the D-TX GRANTED PDU indicates "transmission granted" then the gateway shall:

- remain in DM state CALL ACTIVE TX RESERVATION; and
- issue a CONFIGURE request for TM lower layer traffic configuration; and
- send a U-TX CEASED PDU to the SwMI (and, on receiving a D-TX CEASED PDU or a REPORT indication of successful or unsuccessful transmission of the U-TX CEASED PDU by the TM lower layers, shall then issue a CONFIGURE request to the TM lower layers to switch the U-plane off).

NOTE: If the gateway had stopped DM transmit requests during the WAIT period then, on receipt of the D-TX CONTINUE or D-TX GRANTED PDU, it should indicate that DM transmit requests are now permitted.

9.3.3.7 SwMI initiated call continuation

The SwMI may decide to change the call time-out time by sending a D-INFO PDU with a new T310 value. Upon reception of the D-INFO PDU containing the "call time-out" element, the gateway shall start T310 using the value provided.

The SwMI may also choose to reset the call time-out time T310 and start it again using the current defined value. Upon reception of the D-INFO PDU with the "reset call time-out timer" element indicating that T310 shall be reset, T310 shall be started using the value defined earlier.

The SwMI may also change or reset the call time-out time during call restoration when it sends the D-CALL RESTORE PDU.

9.3.3.8 Call modification

9.3.3.8.1 DM-MS initiated call modification

If a DM-GTX REQUEST or DM-GPREEMPT PDU from a DM-MS indicates a service change then the gateway may send a U-INFO PDU to the SwMI. It shall wait for a D-INFO from the SwMI before accepting the DM-MS's requested service in the DM-GTX ACCEPT or DM-GPRE ACCEPT PDU.

9.3.3.8.2 SwMI initiated call modification

If during a call the gateway receives a D-INFO PDU from the SwMI requesting a service change, the gateway may accept or reject the requested change. If it is a service that DMO does not support (e.g. duplex call or multi-slot call), or a change the gateway cannot support, then the gateway should disconnect the call by sending a U-DISCONNECT PDU to the SwMI, sending a DM-GRELEASE PDU to the current master DM-MS if the gateway is currently a slave on the DM channel or a DM-RELEASE PDU if it is currently the master, and returning to state IDLE.

NOTE 1: A change from point-to-multipoint to point-to-point may be accepted, in which case the gateway continues to support the group call on the DMO side and a point-to-point call on the TMO side. A change from point-to-point to point-to-multipoint may be accepted, in which case the gateway continues to support the individual call on the DMO side and supports a group call on the TMO side using the temporary address provided as the destination group address for the group call. Precisely how such changes are supported is outside the scope of the present document.

If a gateway in DM state CALL ACTIVE TX RESERVATION receives a D-INFO PDU from the SwMI indicating an acceptable service change to the current ongoing call that the DM-MS must be informed about, it should map and send the new call service information in a DM-SETUP PDU. It shall then send a DM-TX CEASED PDU and return to DM state CALL ACTIVE TX RESERVATION.

NOTE 2: Service changes that should be signalled to the DM-MS include data to speech, speech to data and change in end-to-end encryption.

9.3.3.9 Call disconnection

Either the calling or called user application may initiate a call disconnection at any state of a call. Also call disconnection may be caused by expiry of the TMO call length timer T310.

9.3.3.9.1 Reception of DM-RELEASE from current master DM-MS (or call lost)

In the case where the gateway is a slave on the DM channel and receives a DM-RELEASE PDU from the current master DM-MS (or if the gateway receives a GMC-REPORT indication reporting that the DM channel has been lost), the gateway shall obey the following procedure:

- For an individual call or a group call where the gateway is the call owner, the gateway shall:
 - send a U-DISCONNECT PDU to the SwMI;
 - stop timers T311 and T310;
 - start timer T308; and
 - enter TMO state CALL-DISCONNECT.
- The SwMI should respond to the U-DISCONNECT PDU by sending a D-RELEASE PDU. On receipt of a D-RELEASE PDU or a REPORT indication of failed PDU transfer, or if timer T308 expires, the gateway shall stop all timers, issue a CONFIGURE request to the TM lower layers to switch the U-plane off and return to state IDLE.
- Otherwise, for a group call where the gateway is not the call owner, the gateway shall send a U-TX CEASED PDU. On receipt of a D-TX CEASED PDU from the SwMI (or a REPORT indication of successful or unsuccessful transmission of the U-TX CEASED PDU by the TM lower layers), the gateway shall stop all timers, issue a CONFIGURE request to the TM lower layers to switch the U-plane off and return to state IDLE.

NOTE: For a group call where the gateway is not the call owner, the gateway may or may not provide filtering of subsequent TMO late entry signalling.

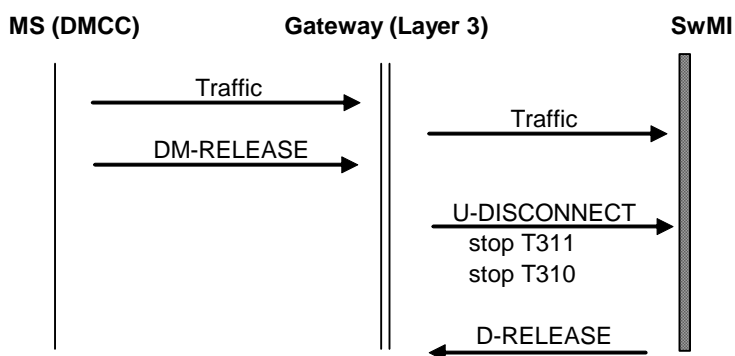

Figure 22: Call disconnection by master DM-MS

9.3.3.9.2 Call disconnection by SwMI

In the case where the SwMI cannot support a request or call from the gateway, it sends a D-RELEASE PDU, containing the reason for disconnection, to the gateway.

On receiving a D-RELEASE PDU from the SwMI a gateway, in the case that it is currently the master of the DM channel, shall send a DM-RELEASE PDU, stop all timers, issue a CONFIGURE request to the TM lower layers to switch the U-plane off and return to state IDLE.

In the case where the gateway is currently a slave on the DM channel and receives a D-RELEASE PDU, it shall send a DM-RELEASE PDU to the current master DM-MS, stop all timers, issue a CONFIGURE request to the TM lower layers to switch the U-plane off and return to state IDLE.

If the gateway receives a D-DISCONNECT PDU from the SwMI then it shall obey the procedures defined above for receipt of a D-RELEASE PDU and shall also respond by sending a U-RELEASE PDU.

9.3.3.9.3 Expiry of call length timer

On expiry of timer T310:

- for an individual call or a group call where the gateway is the call owner, the gateway shall send a U-DISCONNECT PDU to the SwMI and start timer T308 and, on receipt of a D-RELEASE PDU or a REPORT indication of failed PDU transfer or if timer T308 expires, shall stop all timers and issue a CONFIGURE request to the TM lower layers to switch the U-plane off;
- for a group call where the gateway is not the call owner, the gateway shall stop all timers and issue a CONFIGURE request to the TM lower layers to switch the U-plane off.

If the gateway is currently a slave on the DM channel, it shall send a DM-GRELEASE PDU to the current master DM-MS; otherwise it shall send the DM-RELEASE PDU. It shall then return to state IDLE.

9.3.3.10 TMO call restoration

A gateway in channel occupation as either master or slave shall conduct the following procedures in the case where the TM channel resource becomes temporarily unavailable:

- If a gateway in DM state CALL ACTIVE TX OCCUPATION receives a BREAK indication indicating that a temporary break in the TMO radio link has occurred, it shall:
 - issue a CONFIGURE request to the TM lower layers to switch the U-plane off;
 - send a DM-TX CEASED to the called DM-MS(s); and
 - enter DM state CALL ACTIVE TX RESERVATION.
- If a gateway in DM state CALL ACTIVE RX OCCUPATION receives a BREAK indication indicating that a temporary break in the TMO radio link has occurred, it shall:
 - issue a CONFIGURE request to the TM lower layers to switch the U-plane off;
 - send a DM-PREEMPT PDU to the current master DM-MS; and
 - enter DM state WAIT RSP OCCUPATION.

After sending the DM-PREEMPT PDU the gateway shall wait for a GMA-REPORT indication reporting on the progress of the pre-emption request:

- if it receives a GMA-REPORT indication reporting that the pre-emption has failed or that the DM channel has become "free" then it shall return to state IDLE;
- if it receives a DM-PRE ACCEPT PDU from the current master DM-MS then it shall enter DM state CALL ACTIVE TX RESERVATION.

When the gateway receives an indication that the TMO resource is now available it shall follow the appropriate TMO procedure described in EN 300 392-2 [5], clause 14.5. (Also, if the gateway had stopped DM transmit requests during the BREAK period, it should indicate that DM transmit requests are now permitted).

9.3.3.11 Unsolicited D-TX GRANTED PDU

If the gateway receives a D-TX GRANTED PDU indicating "transmission granted" when a DM-MS is not waiting to transmit or send data then the gateway shall:

- issue a CONFIGURE request for TM lower layer traffic configuration; and
- send a U-TX CEASED PDU to the SwMI (and, on receiving a D-TX CEASED PDU or a REPORT indication of successful or unsuccessful transmission of the U-TX CEASED PDU by the TM lower layers, shall then issue a CONFIGURE request to the TM lower layers to switch the U-plane off).

9.3.3.12 Extension and end of reservation period

If the gateway is in DM state CALL ACTIVE TX RESERVATION and the DM reservation period will soon expire, the gateway may issue a GMC-CONFIGURE request to instruct the DM layer 2 to extend the reservation period.

If the gateway is in DM state CALL SETUP PRES_CHECK ORIGINATING or CALL SETUP TERMINATING and the DM reservation period will soon expire, the gateway should issue a GMC-CONFIGURE request to instruct the DM layer 2 to extend the reservation period.

NOTE 1: If the gateway decides to extend the DM reservation period then it should issue the GMC-CONFIGURE request a few seconds before the expiry time so that all DM-MSs can receive the new value of the "reservation time remaining".

NOTE 2: Gateway designers should be aware that repeated extension of the DM reservation period could disrupt other DM users.

If the reservation period expires then:

- for an individual call or a group call where the gateway is the call owner (or for a group call set-up), the gateway shall send a U-DISCONNECT PDU to the SwMI;
- for a group call where the gateway is not the call owner and the gateway has sent a U-TX DEMAND PDU, the gateway shall send a U-TX CEASED PDU to the SwMI.

The gateway shall then stop all timers and return to state IDLE.

9.3.4 Gateway pre-emption procedures

9.3.4.1 DM-MS pre-emption of a gateway operating as master

In the case where a gateway is currently the master of the DM channel and receives either a DM-GPREEMPT PDU or DM-PREEMPT PDU from a DM-MS it shall first check that the request is valid e.g. that the priority is pre-emptive priority or emergency pre-emptive priority and, for a new call pre-emption, that it is of a higher priority than the current ongoing call.

When the gateway receives a DM-PREEMPT message for a new call (i.e. "new call pre-emption" element set to 1), it shall use the priority level to decide whether the request is valid, i.e. it shall check that the priority is pre-emptive priority or emergency pre-emptive priority and is higher than the ongoing call. It may perform additional checks on the validity of the pre-emption request based on security criteria and, for a non-emergency request, it may also perform further additional checks on the validity. However the gateway should not use its list of users that are valid to access the gateway, or its list of registered users, to decide whether to accept an emergency pre-emption request because the request may relate to a direct MS-MS call or a call through another gateway or repeater.

When the gateway receives a pre-emption request relating to the ongoing call, or a changeover request, it may use other information to decide whether to accept the request. For example, it may use the priority, information about the requested transaction and the DM-MS address to decide whether to accept the request. It is recommended that, if the gateway checks the DM-MS address, it should use its list of valid users (if implemented), not its list of registered users.

NOTE 1: Use of the gateway's list of registered DM-MSs for this checking may not be appropriate because:

- a) registration is optional for a DM-MS using a gateway; and
- b) even if a DM-MS performs registration, it may need to make a call before it has registered; and
- c) a DM-MS may initiate call set-up requests through the gateway after attempting registration and receiving a registration rejection with cause other than "ITSI not known to gateway" or "request rejected by gateway" (see clause 6.4.5).

If the pre-emption request is not valid then the gateway shall send to the requesting DM-MS either a DM-GREJECT PDU (if the request was sent using a DM-GPREEMPT PDU) or DM-REJECT PDU (if the request was sent using a DM-PREEMPT PDU).

NOTE 2: The gateway should reject a DM-PREEMPT PDU requesting to send short data within the ongoing call if it does not support the short data service.

Otherwise, if the pre-emption request is valid, the gateway shall conduct the appropriate pre-emption procedure described in the following clauses.

9.3.4.1.1 New call pre-emption during call set-up

If a gateway in DM state CALL SETUP PRES_CHECK ORIGINATING or CALL SETUP TERMINATING receives a DM-PREEMPT PDU indicating new call pre-emption and the pre-emption request is valid then it shall immediately:

- send a DM-PRE ACCEPT PDU addressed to the pre-empting DM-MS;
- send a U-DISCONNECT PDU to the SwMI; and
- return to state IDLE.

9.3.4.1.2 New call pre-emption during DM channel occupation

If a gateway in DM state CALL ACTIVE TX OCCUPATION receives a DM-PREEMPT PDU indicating new call pre-emption and the pre-emption request is valid then it shall immediately:

- send a DM-PRE ACCEPT PDU addressed to the pre-empting DM-MS;
- send a DM-RELEASE PDU addressed to the slave DM-MS(s) in the current call; and
- stop timer T310.

Also, for a group call where the gateway is not the call owner, the gateway shall issue a CONFIGURE request to the TM lower layers to switch the U-plane off and return to state IDLE.

For an individual call or a group call where the gateway is the call owner, the gateway shall send a U-DISCONNECT PDU to the SwMI and start timer T308 and, on receiving a D-RELEASE PDU or a REPORT indication of failed PDU transfer or if timer T308 expires, shall issue a CONFIGURE request to the TM lower layers to switch the U-plane off and return to state IDLE.

NOTE: This pre-emption procedure can be used either to start a new circuit mode call or short data transmission on the DM channel.

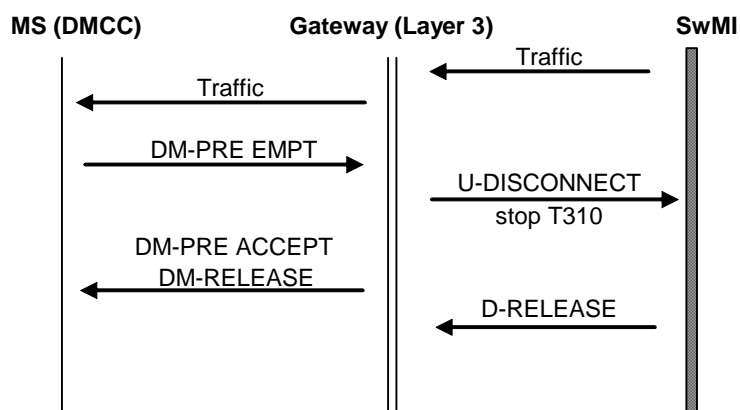

Figure 23: DM-MS new call pre-emption during occupation

9.3.4.1.3 New call pre-emption during DM channel reservation

If a gateway in DM state CALL ACTIVE TX RESERVATION receives a DM-PREEMPT PDU indicating new call pre-emption and the pre-emption request is valid then it shall immediately:

- send a DM-PRE ACCEPT PDU addressed to the pre-empting DM-MS;
- stop timer T310;
- send a U-DISCONNECT PDU to the SwMI (in the case of an individual call or a group call where the gateway is the call owner);

- send a U-TX CEASED to the SwMI (in the case of a group call where the gateway is not the call owner and the gateway has sent a U-TX DEMAND PDU); and
- return to state IDLE.

9.3.4.1.4 DM-MS pre-emption during DM channel occupation to continue existing call

NOTE 1: The gateway procedure for DM-MS pre-emption to continue the existing call during DM channel reservation is described in clause 9.3.3.4.1.

If a gateway in DM state CALL ACTIVE TX OCCUPATION receives a pre-emption request in a DM-GPREEMPT PDU and the request is valid then it shall map and send the DM-GPREEMPT PDU elements in a U-TX DEMAND PDU using the priority level mapped from the DM-GPREEMPT PDU. The gateway may also send a DM-GACK PDU to the requesting DM-MS indicating that the DM-GPREEMPT PDU was successfully received.

NOTE 2: The gateway may send the DM-GACK also at other times, if it needs to extend the requesting DM-MS's waiting time (DT308).

The progress of the transmission of the U-TX DEMAND PDU shall be reported locally within the gateway in one or more REPORT indication primitives. If the gateway receives a REPORT indication reporting failed transmission of the U-TX DEMAND PDU then it shall send a DM-GREJECT PDU to the requesting DM-MS and remain in DM state CALL ACTIVE TX OCCUPATION.

Otherwise the gateway shall wait for a response from the SwMI:

- If the gateway receives a D-TX GRANTED PDU indicating that the transmission request has been rejected then it shall send a DM-GREJECT PDU to the requesting DM-MS and remain in DM state CALL ACTIVE TX OCCUPATION.
- If the SwMI places the transmission request in a queue, this is indicated to the gateway using the transmission request queued parameter value in the D-TX GRANTED PDU. In this case the gateway shall remain in state CALL ACTIVE TX OCCUPATION and may send a DM-GACK PDU to the requesting DM-MS.
- If the gateway receives a D-TX GRANTED PDU indicating that transmission has been granted to the requesting DM-MS then it shall:
 - send a DM-GPRE ACCEPT PDU addressed to the requesting DM-MS;
 - send a DM-TX CEASED PDU addressed to the current slave DM-MS(s) in the call;
 - enter DM state CALL SETUP TERMINATING;
 - start timers T311 and DT365; and
 - issue a CONFIGURE request for TM lower layer traffic configuration.
- The gateway shall then wait for signalling to be sent by the pre-empting DM-MS.
 - If timer DT365 expires then the gateway shall:
 - stop timer T311;
 - send a U-TX CEASED PDU to the SwMI (and, on receiving a D-TX CEASED PDU or a REPORT indication of successful or unsuccessful transmission of the U-TX CEASED PDU by the TM lower layers, shall then issue a CONFIGURE request to the TM lower layers to switch the U-plane off);
 - issue a GMC-CONFIGURE request to indicate DM channel reservation; and
 - enter DM state CALL ACTIVE TX RESERVATION.
 - Otherwise, on receiving a DM-SETUP PDU containing the same destination address as the ongoing call and basic service information consistent with the earlier signalling, the gateway shall:
 - stop timer DT365;
 - enter DM state CALL ACTIVE RX OCCUPATION; and

- issue a GMC-CONFIGURE request for DM lower layer traffic configuration.

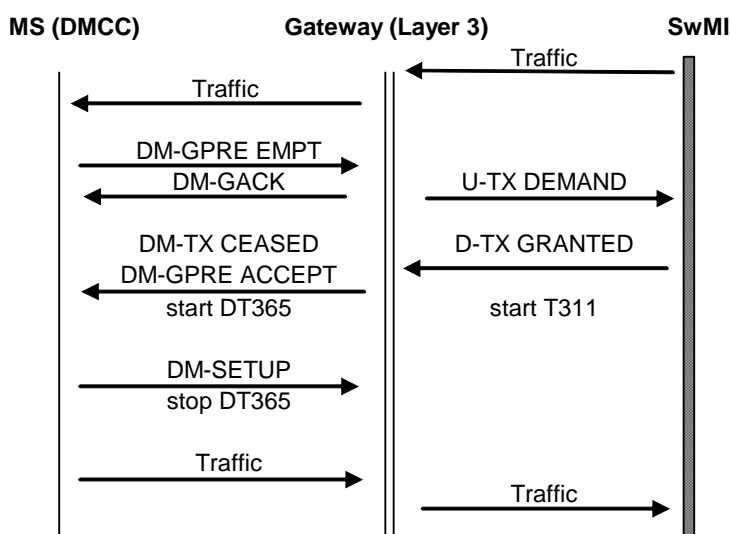

Figure 24: DM-MS pre-emption for continuation of ongoing call

9.3.4.1.5 DM-MS pre-emption during DM channel occupation to send short data within ongoing call

NOTE: The gateway procedure during DM channel reservation for DM-MS pre-emption to send short data within the existing call is described in clause 9.3.3.4.2.

If a gateway in DM state CALL ACTIVE TX OCCUPATION receives a pre-emption request in a DM-PREEMPT PDU indicating that a DM-MS wants to send short data within the existing call and the request is valid then the gateway shall:

- send a DM-PRE ACCEPT PDU addressed to the requesting DM-MS;
- send a DM-TX CEASED PDU addressed to the slave DM-MS(s) in the call;
- enter DM state CALL ACTIVE TX RESERVATION; and
- start timer DT366.
- The gateway shall then wait to receive the short data message from the pre-empting DM-MS:
 - On receiving a DM-SDS DATA or DM-SDS UDATA PDU, the gateway shall follow the procedures for reception and subsequent TMO transmission of short data described in clause 9.4.2.1.
 - On receiving a GMC-REPORT indication reporting the end of the DM SDS occupation period, the gateway shall stop timer DT366. Then, in the case where the TMO call transaction is still ongoing, the gateway shall:
 - send a DM-SETUP PDU to continue the previous call transaction; and
 - return to DM state CALL ACTIVE TX OCCUPATION.
- Otherwise, in the case where the TMO call transaction is not still ongoing, the gateway shall:
 - issue a GMC-CONFIGURE request to indicate a return to channel reservation; and
 - return to DM state CALL ACTIVE TX RESERVATION.

- If timer DT366 expires, and layer 2 has not reported that the channel is in SDS occupation, then, in the case where the TMO call transaction is still ongoing, the gateway shall:
 - send a DM-SETUP PDU to continue the previous call transaction; and
 - return to DM state CALL ACTIVE TX OCCUPATION.
- Otherwise, in the case where the TMO call transaction is not still ongoing, the gateway shall:
 - issue a GMC-CONFIGURE request to indicate a return to channel reservation; and
 - return to DM state CALL ACTIVE TX RESERVATION.

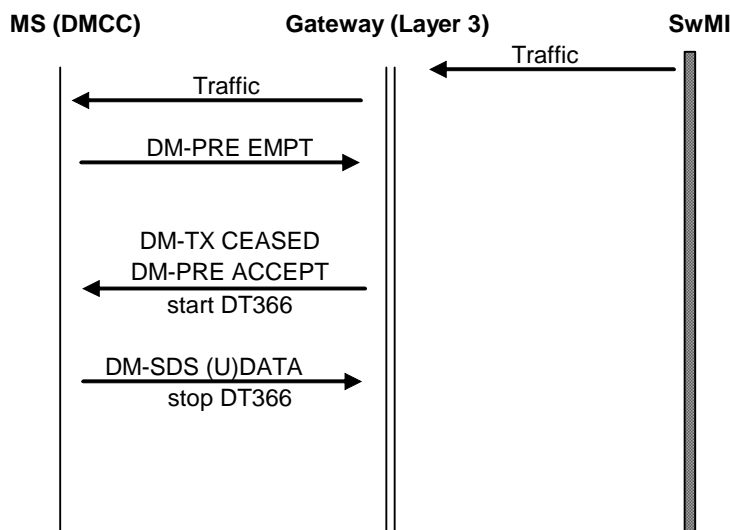

Figure 25: Pre-emption to send short data within ongoing call

9.3.4.2 Pre-emption procedures during gateway slave operation

9.3.4.2.1 Transmission interrupt from TMO

In the case where the gateway is currently a slave on the DM channel and it has received a D-TX WAIT PDU or an individually addressed D-TX INTERRUPT or D-TX CEASED PDU from the SwMI indicating that TMO transmit permission has been lost, it shall:

- stop sending traffic over the TMO air interface;
- stop timer T311;
- send a DM-PREEMPT PDU to the current master DM-MS; and
- enter DM state WAIT RSP OCCUPATION.

After sending the DM-PREEMPT PDU the gateway shall wait for a GMA-REPORT indication reporting on the progress of the pre-emption request:

- If the gateway receives a GMA-REPORT indication reporting failure to transmit the DM-PREEMPT PDU because the channel has become "free" then it shall:
 - send a U-DISCONNECT PDU to the SwMI (in the case of an individual call or a group call where the gateway is the call owner); and
 - return to state IDLE.
- If the gateway receives a GMA-REPORT indication reporting that the pre-emption has failed, then it shall:
 - issue a GMC-CONFIGURE request to indicate idle operation;

- send a U-DISCONNECT PDU to the SwMI (in the case of an individual call or a group call where the gateway is the call owner); and
- return to state IDLE.

NOTE: In the case where the pre-emption request has failed the gateway relies on the presence signal to inform all current DM users of the channel state change.

- Otherwise, on receiving a DM-PRE ACCEPT PDU from the master DM-MS:
 - in the case where the gateway had received a D-TX WAIT or D-TX CEASED PDU, or a D-TX INTERRUPT PDU where transmission permission was not assigned to any party, the gateway shall enter state CALL ACTIVE TX RESERVATION; or
 - in the case where the gateway had received a D-TX INTERRUPT PDU indicating that transmit permission was assigned to another user, the gateway shall:
 - issue a CONFIGURE request for TM lower layer traffic configuration;
 - map and send the elements of the D-TX INTERRUPT PDU in a DM-SETUP PDU;
 - enter DM state CALL ACTIVE TX OCCUPATION; and
 - issue a GMC-CONFIGURE request for DM lower layer traffic configuration.

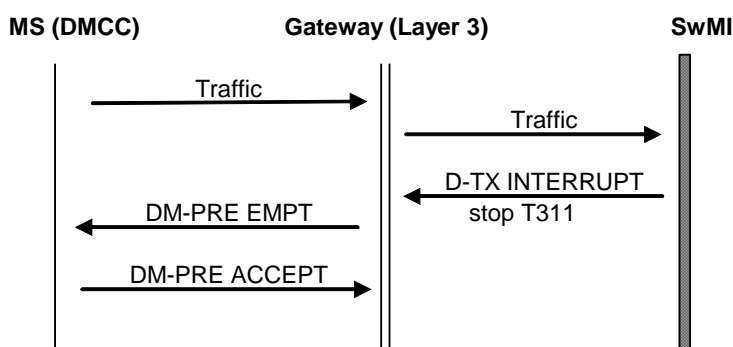

Figure 26: Incoming TMO TX interruption

9.3.4.2.2 Pre-emption initiated by gateway during an ongoing call

A gateway operating as a slave in a call transaction may need to initiate the pre-emption procedure because, for example, the TMO call transaction timer T311 has expired or in order to exercise a DM channel timing change. In this case it shall:

- stop timer T311;
- send a U-TX CEASED PDU to the SwMI (and, on receiving a D-TX CEASED PDU or a REPORT indication of successful or unsuccessful transmission of the U-TX CEASED PDU by the TM lower layers, shall then issue a CONFIGURE request to the TM lower layers to switch the U-plane off);
- send a DM-PREEMPT PDU to the current master DM-MS; and
- enter DM state WAIT RSP OCCUPATION.

After sending the DM-PREEMPT PDU the gateway shall wait for a GMA-REPORT indication reporting on the progress of the pre-emption request:

- If the gateway receives a GMA-REPORT indication reporting failure to transmit the DM-PREEMPT PDU because the channel has become "free" then it shall:
 - send a U-DISCONNECT PDU to the SwMI (in the case of an individual call or a group call where the gateway is the call owner); and

- return to state IDLE.
- If the gateway receives a GMA-REPORT indication reporting that the pre-emption has failed, then it shall:
 - issue a GMC-CONFIGURE request to indicate idle operation;
 - send a U-DISCONNECT PDU to the SwMI (in the case of an individual call or a group call where the gateway is the call owner); and
 - return to state IDLE.

NOTE: In the case where the pre-emption request has failed the gateway relies on the presence signal to inform all current DM users of the channel state change.

- Otherwise, on receiving a DM-PRE ACCEPT PDU from the master DM-MS, the gateway shall enter state CALL ACTIVE TX RESERVATION.

9.3.4.2.3 New call pre-emption by gateway

A gateway which is active within a call may receive a D-SETUP PDU from the SwMI for a new call. If the gateway decides not to proceed with the new call set-up request then it shall send a U-DISCONNECT PDU to the SwMI for the new call (in the case of an incoming individual call) and shall remain in its current state.

If the gateway is currently a slave on the DM channel and it decides to proceed with the new call set-up then it shall:

- send a DM-PREEMPT PDU to the current master DM-MS; and
- enter DM state WAIT RSP OCCUPATION.

NOTE 1: If the gateway is currently master on the DM channel and it decides to proceed with the new call set-up then it sends a U-DISCONNECT PDU to the SwMI for the old call (for an individual call or a group call where the gateway was the call owner). It also sends DM-RELEASE to the slave DM-MS(s) in the old call and then sends either a DM-SETUP PDU or DM-SETUP PRES PDU as appropriate and follows the required procedure detailed in clause 9.3.1.

After sending the DM-PREEMPT PDU the gateway shall wait for a GMA-REPORT indication reporting on the progress of the pre-emption request:

- If the gateway receives a GMA-REPORT indication reporting failure to transmit the DM-PREEMPT PDU because the channel has become "free" then it shall send either a DM-SETUP PDU or DM-SETUP PRES PDU as appropriate and follow the required procedure detailed in clause 9.3.1.
- If the gateway receives a GMA-REPORT indication reporting that the pre-emption has failed, then it shall:
 - send a U-DISCONNECT PDU to the SwMI for the new call (in the case of an incoming individual call); and
 - either return to the DM state of CALL ACTIVE RX OCCUPATION within the old call or return to state IDLE.
- Otherwise, on receiving a DM-PRE ACCEPT PDU from the master DM-MS, the gateway shall send either a DM-SETUP PDU or DM-SETUP PRES PDU as appropriate and follow the required procedure detailed in clause 9.3.1.

NOTE 2: Also, when the gateway has decided not to support the old call, it sends a U-DISCONNECT PDU to the SwMI for the old call (for an individual call or a group call where the gateway was the call owner) or otherwise a U-TX CEASED PDU. This may, for example, be on receipt of the D-SETUP for the new call or on receipt of DM-PRE ACCEPT from the old master.

9.3.4.2.4 Pre-emption by another DM-MS

In the case where another DM-MS pre-empts the current master DM-MS, the gateway receives the master DM-MS's DM-TX CEASED PDU (for a pre-emption to continue the ongoing call) or DM-RELEASE PDU (for a new call pre-emption).

If the gateway receives DM-TX CEASED from the master DM-MS then it shall follow the end of transmission procedure defined in clause 9.3.3.1.1.

NOTE: If the end of transmission was caused by a DM-MS pre-emption then, if the pre-empting DM-MS requires a circuit mode transaction, it sends a DM-GTX REQUEST PDU to the gateway. However, if the pre-empting DM-MS requires a short data transaction, it sends the short data as soon as it has received the master DM-MS's pre-emption acceptance. Therefore, the gateway should expect that it may sometimes receive short data during channel reservation without having sent a DM-TX ACCEPT or DM-PRE ACCEPT message.

If the gateway receives DM-RELEASE from the master DM-MS then it shall follow the call disconnection procedure defined in clause 9.3.3.9.1.

9.3.4.3 Pre-emption procedure when gateway idle

If an idle gateway wishes to initiate a new call and the DM channel is currently busy, then the gateway may employ the new call pre-emption procedure from EN 300 396-3 [3], clause 6.2.6.

The gateway may also use the new call pre-emption procedure to pre-empt another gateway during a registration phase.

9.4 Layer 3 short data service procedures

This clause describes the gateway layer 3 procedures for handling short data messages. These procedures apply for a gateway if it supports the short data service.

9.4.1 Incoming SDS message from TMO

Incoming SDS messages from the SwMI may arrive in either a D-STATUS PDU or a D-SDS DATA PDU.

Following the receipt of the incoming TMO SDS message and in the case where the DM channel is currently not free, the gateway shall decide whether to employ the DM pre-emption procedures appropriate to the ongoing call. If the gateway decides not to pre-empt then it may either discard the SDS message or hold the SDS message until the DM channel becomes free and send the SDS message using the appropriate procedure described in the following clauses.

9.4.1.1 Transmission of short data message from TMO using DM unacknowledged service

If a gateway which is currently IDLE on a free DM channel receives either a D-STATUS PDU or D-SDS DATA PDU with a valid group address then it shall:

- map and send the contents in a DM-SDS UDATA PDU; and
- enter DM state UNACK'D SHORT DATA INITIATED.

When the gateway sends the DM-SDS UDATA PDU, it may instruct layer 2 to transmit the complete message several times (up to a maximum of DN367 times). The gateway may use either of the approaches defined in EN 300 396-3 [3], clause 6.3.1.1.1, i.e. the DM-SDS UDATA PDU may be sent either several times within a single transaction or, except in the case of short data sent as a transaction within a circuit mode call, as several separate transactions with a gap permitted between the transactions, though in each case the maximum is DN367 times.

Having sent the DM-SDS UDATA PDU the gateway shall then wait for a GMA-REPORT indication reporting on the progress of the transmission:

- If the gateway receives a GMA-REPORT indication reporting failure to transmit the DM-SDS UDATA PDU because the DM channel has become busy then it shall either:
 - invoke the pre-emption procedures appropriate to the ongoing call; or
 - discard the message and return to state IDLE; or
 - wait until the channel becomes free and attempt to send the SDS message again.

- If the gateway receives a GMA-REPORT indication reporting that the DM-SDS UDATA PDU has been transmitted the required number of times then the gateway shall return to its previous state.

9.4.1.2 Transmission of short data message from TMO using DM acknowledged service

If a gateway which is currently IDLE on a free DM channel receives either a D-STATUS PDU or D-SDS DATA PDU with a valid individual address then it shall either send the message using the DM unacknowledged service as defined in clause 9.4.1.1 or shall:

- map and send the contents in a DM-SDS DATA PDU; and
- enter DM state ACK'D SHORT DATA INITIATED.

Having sent the DM-SDS DATA PDU the gateway shall then wait for a GMA-REPORT indication reporting on the progress of the transmission:

- If the gateway receives a GMA-REPORT indication reporting failure to transmit the DM-SDS DATA PDU because the DM channel has become busy then it shall either:
 - invoke the pre-emption procedures appropriate to the ongoing call; or
 - discard the message and return to state IDLE; or
 - wait until the channel becomes free and attempt to send the SDS message again.
- If the gateway receives a GMA-REPORT indication reporting that the DM-SDS DATA PDU has been transmitted then it shall start timer DT369 and wait for a response from the called DM-MS:
 - If timer DT369 expires then the gateway shall either send the DM-SDS DATA PDU again (without indicating "immediate retransmission" in the GMA-UNITDATA request) or return to its previous state. It shall attempt the short data transmission up to a maximum of DN369 times if no acknowledgement has been received.

NOTE 1: The gateway may choose to delay re-sending the DM-SDS DATA PDU after timer DT369 expires in case there may be a temporary propagation problem. This does not apply in the case of short data sent as a transaction within a circuit mode call.

- If the gateway receives an incomplete DM-SDS ACK or a DM-SDS ACK with incorrect FCS, or receives a DM-SDS ACK indicating that the DM-SDS DATA message was received but the FCS failed or that the DM-SDS DATA message was not fully received, then it shall:
 - stop timer DT369; and
 - either send the DM-SDS DATA PDU again (indicating "immediate retransmission" in the GMA-UNITDATA request) or return to its previous state; it shall attempt the short data transmission up to a maximum of DN368 times if a negative response has been received.
- If the gateway receives a DM-REJECT PDU then it shall stop timer DT369 and return to its previous state.
- Otherwise, if the gateway receives a DM-SDS ACK indicating that the DM-SDS DATA message was fully received then it shall stop timer DT369 and return to its previous state.

If the DM-SDS ACK contained a short data message then the gateway shall map and send the data over the Um air interface in either a U-SDS DATA or a U-STATUS PDU.

NOTE 2: DM-SDS ACK does not contain 'calling party TSI', 'external subscriber number' or 'area selection'. Therefore when the gateway constructs the U-SDS DATA or U-STATUS PDU, it may have to obtain the 'DM-MM address' and 'external subscriber number' information elements from the original incoming D-SDS DATA, and it should set 'area selection' to 0000₂.

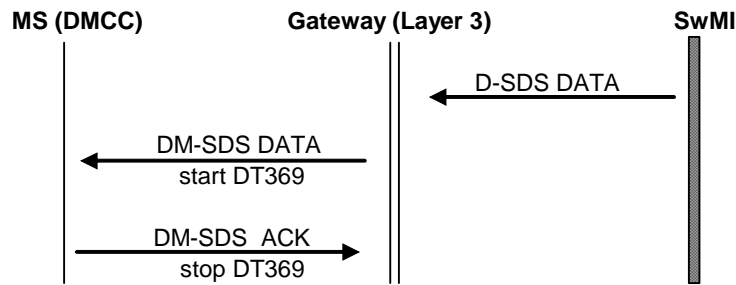

Figure 27: Incoming SDS message from TMO

9.4.1.3 Pre-emption of DM unacknowledged or acknowledged SDS transaction

If the gateway during transmission of either a DM-SDS UDATA PDU or DM-SDS DATA PDU receives a DM-GPREEMPT or DM-PREEMPT PDU then it shall check that the request is valid.

If the pre-emption request is not valid the gateway shall ignore the request and remain in its current state.

If the pre-emption request is valid the gateway shall immediately send a DM-GPRE ACCEPT or DM-PRE ACCEPT PDU to the pre-empting DM-MS.

- In the case of a new call pre-emption the gateway shall return to state IDLE and may either discard the short data message from TMO or retain it and attempt to resend it when the channel becomes free.
- In the case of a pre-emption within the ongoing call the gateway, following the transmission of the pre-emption acceptance PDU, shall start timer DT365 (for DM-GPRE ACCEPT) or DT366 (for DM-PRE ACCEPT). The gateway shall then wait to receive signalling from the DM-MS. The gateway may either discard the short data message from TMO or retain it and attempt to resend it when the channel becomes reserved or free.
- If timer DT365 or DT366 expires without receipt of signalling from the DM-MS then the gateway shall either attempt to send the TMO short data message again or return to its previous state.

9.4.1.4 Transmission of short data message from TMO during DM channel occupation

If a gateway which is master of the DM channel in state CALL ACTIVE TX OCCUPATION receives a valid D-SDS DATA or D-STATUS PDU then:

- in the case that the message is for the current ongoing call and can be transmitted within one stolen timeslot, the gateway may send a DM-SDS UDATA PDU (using stealing channel mechanism); or
- in the case that the message is for the current ongoing call but cannot be sent within a single timeslot, the gateway should hold the message until the DM channel goes into reservation and then send the short data message using the procedure described in clause 9.4.1.5; or
- if the message is not for the current call, the gateway may wait for end of the call and then send the short data message or may force the end of the current DM call by sending a DM-RELEASE PDU and then send the short data message; in either case the gateway sends the message using the procedures described in either clauses 9.4.1.1 or 9.4.1.2.

If a gateway which is currently operating as slave during DM channel occupation receives a valid D-SDS DATA or D-STATUS PDU for the ongoing call then it should wait until the end of the current DM call transaction and then send the short data message using the procedure described in clause 9.4.1.5.

9.4.1.5 Transmission of short data message from TMO during DM channel reservation

If a gateway which is master of the DM channel in state CALL ACTIVE TX RESERVATION receives a valid D-SDS DATA or D-STATUS PDU for the current ongoing call then it may send the TMO short data message using either the DM unacknowledged service (individual call or group call) or the DM acknowledged service (individual call only). It shall use the procedures described in clauses 9.4.1.1 or 9.4.1.2, returning to DM state CALL ACTIVE TX RESERVATION when the transaction has been completed.

If a gateway which is master of the DM channel in state CALL ACTIVE TX RESERVATION receives a valid D-SDS DATA or D-STATUS PDU not for the current ongoing call then it may wait for end of the call and then send the short data message or may force the end of the current DM call by sending a DM-RELEASE PDU and then send the short data message. In either case the gateway sends the message using the procedures described in either clauses 9.4.1.1 or 9.4.1.2.

9.4.2 Outgoing DM SDS message to TMO

9.4.2.1 Reception of outgoing SDS message on DM channel

A gateway shall only begin outgoing TMO SDS procedures when the SDS message transfer over the Ud interface has been successfully completed.

The DM-MS may use either the unacknowledged (DM-SDS UDATA PDU) or acknowledged service (DM-SDS DATA PDU) to transfer the SDS message over the Ud interface.

NOTE 1: If the DM-SDS UDATA or DM-SDS DATA PDU did not contain an area selection value then the gateway should use value 0000₂ (area not defined) in the U-SDS DATA or U-STATUS PDU.

NOTE 2: The procedure for mapping and sending the message using a U-SDS DATA or U-STATUS PDU applies only for DMO short data type identifiers 0000₂ to 0100₂.

9.4.2.1.1 Reception of outgoing unacknowledged SDS message on DM channel

On reception of a DM-SDS UDATA PDU containing an incorrect Frame Check Sequence (FCS), the gateway shall discard the data.

In the case where a valid DM-SDS UDATA PDU has been fully received by the gateway it shall be mapped and sent using either a U-SDS DATA or U-STATUS PDU, dependent upon the short data type identifier contained in the DM-SDS UDATA PDU.

NOTE: The gateway may choose to discard repetitions of the same DM-SDS UDATA PDU. The methods by which the gateway decides that a received DM-SDS UDATA PDU contains a layer 2 repetition of the same message (i.e. repeated by the DM-MAC in the sending DM-MS) are outside the scope of the present document.

9.4.2.1.2 Reception of outgoing acknowledged SDS message on DM channel

On reception of a DM-SDS DATA PDU, and if the gateway does not support the short data service, the gateway may send a DM-REJECT PDU and discard the DM-SDS DATA PDU; or, otherwise, it may discard the DM-SDS DATA PDU without sending any response.

On reception of a DM-SDS DATA PDU marked as not fully received by layer 2, the gateway shall discard any data and shall send a DM-SDS ACK PDU indicating that the message was not fully received.

On reception of a DM-SDS DATA PDU marked as fully received by layer 2:

- if the PDU contains an FCS and the FCS is not correct, the gateway shall discard the data and shall send a DM-SDS ACK PDU indicating that the message was received but the FCS failed;
- otherwise the gateway shall send a DM-SDS ACK PDU indicating that the sender's data message was fully received.

When sending a DM-SDS ACK PDU indicating that the sender's data message was fully received, the gateway is not precluded from including a data message within the DM-SDS ACK PDU. It shall not include an FCS within a DM-SDS ACK PDU if it is not including a data message within the PDU.

In the case where a valid DM-SDS DATA message has been fully received by the gateway it shall be mapped and sent using either a U-SDS DATA or U-STATUS PDU, dependent upon the short data type identifier contained in the DM-SDS DATA PDU.

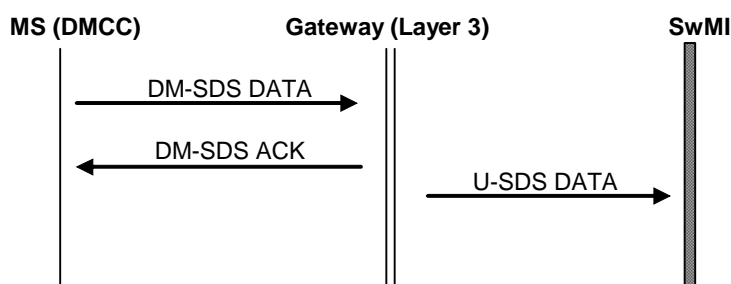

Figure 28: Outgoing DM SDS message to TMO

9.4.2.2 Reception of DM short data sent within ongoing call

A gateway which is currently operating as slave during DM channel occupation may receive a DM-SDS UDATA message from the master DM-MS, in which case it processes the short data message using the procedures described in clause 9.4.2.1.1.

A gateway which is currently operating as master during DM channel occupation may receive a pre-emption request for transmission of short data within the ongoing call; see clause 9.3.4.1.5. Similarly, a gateway which is currently operating as master during DM channel reservation may receive a changeover (or pre-emption) request for transmission of short data within the ongoing call; see clause 9.3.3.4.2. In either case, on receiving a DM-SDS DATA or DM-SDS UDATA message, the gateway uses the procedures described in clause 9.4.2.1.

If the gateway has been operating as slave during DM channel occupation and has received a DM-TX CEASED PDU from the master DM-MS then, if the end of transmission was caused by a DM-MS pre-emption, the gateway may receive a DM-SDS DATA or DM-SDS UDATA message from the pre-empting DM-MS. On receiving a DM-SDS DATA or DM-SDS UDATA message, the gateway uses the procedures described in clause 9.4.2.1.

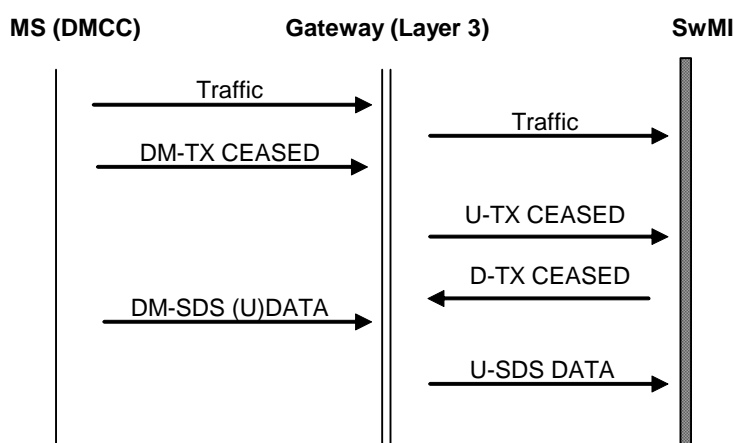

Figure 29: DM-MS pre-emption of ongoing DM-MS call transaction to send short data

9.4.3 SDS-TL Service

At the SDS-TL layer generally the gateway shall act as a relay, i.e. the SDS-TL PDU in the SDS shall be copied from the incoming SDS (DMO or TMO side) to the outgoing SDS (TMO or DMO) without change. The exception to this is that when relaying an SDS-TRANSFER PDU from the DMO side to the TMO side, the gateway shall set "service selection" to "group or individual service".

9.5 Addressing methods on TMO air interface

9.5.1 Receiving group call from TMO

When the gateway receives a group call or short data message from TMO, it receives the D-SETUP, D-SDS DATA or D-STATUS PDU with the group address used as the TMO layer 2 address i.e. using normal TMO operation. It is therefore assumed that the gateway is a member of all the groups that it supports on the DM air interface.

If the gateway then sends a message on behalf of a DM-MS (e.g. a U-TX DEMAND PDU), it uses its own individual address as the TMO layer 2 address. Optionally it may include the address of the DM-MS within the layer 3 PDU as a type 3 element.

The type 3 "DM-MS address" element when used is only used on the link between the gateway and the SwMI. On the link between the SwMI and other TM-MS, the normal TMO addressing is used for the address of the DM-MS. The SwMI performs the required address translation.

Throughout the call, the gateway continues to receive group-addressed messages using the normal TMO group addressing. It sends and receives messages for individual DM-MSs using its own individual address as the TMO layer 2 address (with the DM-MS address optionally included within the layer 3 PDU).

NOTE: The option to include the address of the DM-MS as a type 3 element within the appropriate layer 3 PDUs applies only if the gateway has been accepted by the SwMI to operate as a DM gateway.

9.5.2 Receiving individual call from TMO

When the SwMI wishes to set up an individual call (or send short data) to a DM-MS under the gateway, it sends the message using the gateway's individual address as the TMO layer 2 address. It normally needs to include the DM-MS address within the layer 3 PDU. The exception is for a gateway that is configured to serve only a single DM-MS, in which case the DM-MS address may be regarded as implicit.

The type 3 "DM-MS address" element when used is only used on the link between the gateway and the SwMI. On the link between the SwMI and the calling TM-MS, the normal TMO addressing is used for the address of the called MS because only the SwMI knows the called MS is under a gateway. The SwMI performs the required address translation.

Throughout the call, the gateway continues to send and receive TMO messages using its own individual address as the TMO layer 2 address (with the DM-MS address optionally included within the layer 3 PDU).

NOTE: The option to include the address of the DM-MS as a type 3 element within the appropriate layer 3 PDUs applies only if the gateway has been accepted by the SwMI to operate as a DM gateway.

9.5.3 Call set-up to TMO

When the gateway sends a message on behalf of a DM-MS (e.g. a U-SETUP, U-SDS DATA or U-STATUS PDU), it uses its own individual address as the TMO layer 2 address. Optionally it may include the address of the DM-MS within the layer 3 PDU as a type 3 element.

The type 3 "DM-MS address" element when used is only used on the link between the gateway and the SwMI. On the link between the SwMI and other TM-MS, the normal TMO addressing is used for the address of the DM-MS. The SwMI performs the required address translation.

Throughout a call, the gateway sends and receives messages for individual DM-MSs using its own individual address as the TMO layer 2 address (with the DM-MS address optionally included within the layer 3 PDU). For a group call, the gateway receives group-addressed messages using the normal TMO group addressing.

NOTE: The option to include the address of the DM-MS as a type 3 element within the appropriate layer 3 PDUs applies only if the gateway has been accepted by the SwMI to operate as a DM gateway.

9.6 Information element mapping between TM and DM PDUs

This clause describes the unique information element mappings which have no direct correspondence between DMO and TMO PDUs required for a DM gateway operating with a TETRA TMO compliant SwMI.

All PDU information element codings used by the gateway for operation over the DMO air interface are as specified in clause 14 and in EN 300 396-3 [3], clause 9.

All PDU information element codings used by the gateway for operation over the TMO air interface are as specified in EN 300 392-2 [5].

A gateway shall employ the following mapping between the TMO and DMO information elements.

9.6.1 TMO communication type – DMO call type flag mapping

Communication type			Call type flag		
length	value	remark	length	value	remark
2	00 ₂	Point to point	1	0	Individual call
	01 ₂	Point to multipoint		1	Group call
	10 ₂	Point to multipoint acknowledged		n/a	Not supported
	11 ₂	Broadcast		1	Group call

9.6.2 TMO call priority – DMO priority mapping

Call priority			Priority level		
length	value	remark	length	value	remark
4	0000 ₂	Priority not defined	2	00 ₂	Normal priority call
	0001 ₂	Priority 1		00 ₂ or 01 ₂	Normal or high priority call
	0010 ₂	Priority 2		00 ₂ or 01 ₂	Normal or high priority call
	..etc.	..etc.		00 ₂ or 01 ₂	Normal or high priority call
	1011 ₂	Priority 11		00 ₂ or 01 ₂	Normal or high priority call
	1100 ₂	Pre-emptive priority 1		10 ₂	Pre-emptive priority
	1101 ₂	Pre-emptive priority 2		10 ₂	Pre-emptive priority
	1110 ₂	Pre-emptive priority 3		10 ₂	Pre-emptive priority
	1111 ₂	Pre-emptive priority 4 (Emergency)		11 ₂	Emergency pre-emptive priority

9.6.3 TMO short data type identifier – DMO short data type identifier mapping

Short data type identifier (TMO)			Short data type identifier (DMO)		
length	value	remark	length	value	remark
2	00 ₂	User defined data 1	4	0000 ₂	User defined data 1
	01 ₂	User defined data 2		0001 ₂	User defined data 2
	10 ₂	User defined data 3		0010 ₂	User defined data 3
	11 ₂	User defined data 4		0011 ₂	User defined data 4

NOTE: DMO short data type identifier 0100₂ corresponds to precoded status. It is therefore mapped to the TMO U-STATUS PDU and from the TMO D-STATUS PDU.

9.6.4 TMO TX demand priority – DMO priority level mapping

TX demand priority (TMO)			Priority level (DMO)		
length	value	remark	length	value	remark
2	00 ₂	Low priority level	2	00 ₂	Normal priority call
	01 ₂	High priority level		01 ₂	High priority call
	10 ₂	Pre-emptive priority level		10 ₂	Pre-emptive priority call
	11 ₂	Emergency pre-emptive priority level		11 ₂	Emergency pre-emptive priority call

10 Gateway layer 3 mobility management procedures

10.1 Introduction

This clause describes the layer 3 Mobility Management (MM) protocol for a gateway. It describes both the protocol employed on the TMO side of the gateway and that employed on the DMO side.

10.2 Gateway MM states

10.2.1 MM protocol states – TMO

EN 300 392-2 [5], clause 15.3.5 shall apply.

10.2.2 MM protocol states – DM

10.2.2.1 REGISTRATIONS SOLICITED

This state exists while the gateway is actively soliciting DM-MSs to register their presence (i.e. during a registration phase).

10.2.2.2 REGISTRATIONS NOT PERMITTED

This state exists when the gateway does not wish to receive any registration requests from the DM-MSs.

10.2.2.3 REGISTRATIONS PERMITTED

This state exists when the gateway is not actively soliciting registration requests from the DM-MSs but will process any unsolicited requests.

10.3 Gateway MM procedures

10.3.1 Gateway registration to SwMI

The appropriate procedures in EN 300 392-2 [5], clause 16 shall apply. The cell reselection procedures are optional for a gateway.

Having successfully registered with the SwMI (if required), the gateway may send a U-MM STATUS PDU with status uplink "Request to start DM gateway operation" to the SwMI requesting to start operation as a DM gateway. The procedures are defined in clause 10.3.5 and the status uplink (and status downlink) values are defined in annex B.

NOTE: If the gateway does not wish to include or receive DM-MS individual addresses within TMO PDUs then it need not inform the SwMI that it is operating as a DM gateway. For example, this may apply if the gateway intends to support only group calls or if it is configured to support only a single DM-MS.

If the gateway receives a D-MM STATUS PDU with status downlink "Acceptance to start DM gateway operation" accepting its request to operate as a DM gateway, it may conduct the DM procedures defined in clause 10.3.2.

If the gateway receives a D-MM STATUS PDU with status downlink "Rejection to start DM gateway operation" rejecting its request to operate as a DM gateway, or if it does not receive a D-MM STATUS PDU accepting its request to operate as a DM gateway, it may conduct the DM procedures defined in clause 10.3.2 but shall not forward to the SwMI the individual addresses of any DM-MSs that send registration requests.

If the gateway has been accepted by the SwMI to operate as a DM gateway, and then wishes to stop operating as a DM gateway, it shall send a U-MM STATUS PDU with status uplink "Request to stop DM gateway operation" to inform the SwMI. The procedures are defined in clause 10.3.5.

The gateway shall assume that its gateway mode is lost if it needs to re-register for any reason other than for a periodic registration. For example, its gateway mode is lost when the TMO registered area is changed or after a SwMI initiated registration. Having successfully re-registered with the SwMI, the gateway may send the U-MM STATUS PDU again to re-request to operate as a DM gateway. It may request either to start operation again as a DM gateway, with status uplink "Request to start DM gateway operation", or to continue operation as a DM gateway, with status uplink "Request to continue DM gateway operation". If it asks to start operation again, it shall assume that the SwMI has discarded the previous DM-MS address set; whereas, if it asks to continue operation then, in the response D-MM STATUS PDU with status downlink "Acceptance to continue DM gateway operation", the SwMI indicates whether it still has the DM-MS address set used before the re-registration.

As defined in clause 13 (and in amendments 10 and 11), there are some instances when the gateway may give precedence to DM procedures over TMO requirements to receive on the TM channel. The gateway shall obey the normal criteria for TMO registration as if it had been receiving the TM channel in those slots for which it gives precedence to DM procedures. However, the gateway shall not change the TMO Radio Downlink Counter RDC (see EN 300 392-2 [5], clause 23.7.3.1) as a result of TMO slots for which it does not attempt to receive the AACH because of giving precedence to DM procedures. When the gateway resumes reception of the TM channel, it shall resume updating of the RDC using the usual value of N (i.e. it shall not re-calculate the value of N taking account of the additional time since the last reception).

10.3.2 Gateway MM procedures on DM

The gateway, having successfully registered with the SwMI (if required), may indicate the availability of service to the DM-MSs on the DM RF carrier, using the presence signal. It may offer service only to certain selected DM-MSs or groups of DM-MSs by broadcasting the appropriate address parameters in the presence signal.

The gateway, if not intending to offer service only to a single known DM-MS, may invite (i.e. solicit or permit) registration requests from the DM-MSs to which it is offering service:

- a) If the gateway solicits registration requests then it initiates a specific registration phase in which it controls the DM channel and DM-MSs transmit their requests using the registration random access protocol. The gateway should set the registration access parameter to a value appropriate to the expected mobile population in order to control signalling collisions between the registration requests. The gateway procedures for receiving registration requests during a registration phase are defined in clause 10.3.3.1.
- b) If the gateway permits registration requests then DM-MSs may transmit registration requests (called "unsolicited registration requests") whenever they perceive the channel as being free. The gateway procedures for receiving unsolicited registration requests are defined in clause 10.3.3.2.

The DM-MS requesting registration may include in the registration request a group identity (serviced GSSI) which the MS wishes to use.

NOTE 1: A gateway may invite registration requests in order to decide which groups to support, even if it will not forward the DM-MS individual addresses to the SwMI.

NOTE 2: The gateway needs to be a member of all the groups that it supports. If it is not a member of a group requested by a DM-MS then it should reject the registration request indicating "gateway cannot support requested group".

The gateway should check the validity of the registration requests against its internal list of authorized users before accepting the request.

If the gateway has been accepted by the SwMI to operate as a DM gateway then it may forward to the SwMI the individual addresses of those DM-MSs whose registrations it has accepted, in order that those DM-MSs may receive individual calls from the TMO system. The timing of this is at the discretion of the gateway. The gateway procedures for sending DM-MS individual addresses to the SwMI, and for modifying the SwMI's current set of DM-MS individual addresses, are defined in clause 10.3.5.

If the SwMI subsequently rejects a DM-MS to which the gateway has granted acceptance, the gateway shall then cancel the DM-MS registration.

On granting registration acceptance the gateway labels the registration acceptance. The gateway broadcasts the label identifier in the presence signal to indicate that registrations bearing that registration label are currently valid. It is a gateway option to invalidate current registrations by changing the registration label at appropriate times. Also, the SwMI may instruct the gateway to change the registration label by sending a D-MM STATUS PDU with status downlink "Command to change registration label".

If a gateway has been pre-programmed with the addresses of the DM-MSs that it is serving then, instead of inviting registration requests, it may send that pre-programmed list to the SwMI (if it has been accepted by the SwMI to operate as a DM gateway).

NOTE 3: SwMI designers should note that a DM-MS address list sent by a gateway may not always be entirely reliable as a means of locating users. For example, the list sent by the gateway may sometimes be out-of-date (e.g. if an MS has just moved from DM operation to TMO operation); or there could be security issues since the SwMI cannot authenticate an MS under a gateway. Therefore it is recommended that the SwMI regards the list as indicating an additional location where the MS may be paged rather than deleting its previous record of the MS's location.

10.3.3 Receiving DM registration requests

10.3.3.1 Solicited registration requests

If the gateway initiates a registration phase it shall issue a GMC-CONFIGURE request to layer 2, and shall enter DM state REGISTRATIONS SOLICITED. It shall then wait for any incoming registration requests:

- If it receives a DM-GREGISTER REQUEST PDU, and if it wishes to accept the registration, it shall send a DM-GREGISTER ACCEPT PDU to the requesting DM-MS.
- If it receives a DM-GREGISTER REQUEST PDU, and if it does not wish to accept the registration, it shall send a DM-GREGISTER REJECT PDU to the requesting DM-MS.
- If it receives a DM-PREEMPT PDU requesting pre-emptive use of the DM channel, it shall check that the request is valid e.g. that the priority is pre-emptive priority or emergency pre-emptive priority and is higher than the priority of the registration phase as set in the gateway presence signal:
 - If the pre-emption request is valid then the gateway shall send a DM-PRE ACCEPT PDU addressed to the pre-emptor and shall enter DM state REGISTRATIONS PERMITTED or REGISTRATIONS NOT PERMITTED;
 - Otherwise, if the pre-emption request is not valid, the gateway shall send a DM-REJECT PDU addressed to the pre-emptor and remain in DM state REGISTRATIONS SOLICITED.
- If it receives a GMC-REPORT indication from layer 2 reporting that the registration phase has ended then it shall enter DM state REGISTRATIONS PERMITTED or REGISTRATIONS NOT PERMITTED.

NOTE: If the gateway wishes to withdraw a request for a registration phase or terminate a registration phase prematurely, it may issue a GMC-CONFIGURE request to layer 2 and enter DM state REGISTRATIONS PERMITTED or REGISTRATIONS NOT PERMITTED.

10.3.3.2 Unsolicited registration requests

If, while in DM state REGISTRATIONS PERMITTED, the gateway receives a DM-GREGISTER REQUEST PDU, it shall:

- if wishing to accept the registration, send a DM-GREGISTER ACCEPT PDU to the requesting DM-MS;

- if not wishing to accept the registration request, send a DM-GREGISTER REJECT PDU addressed to the requesting DM-MS.

10.3.4 Registration cancellation

If the gateway wishes to cancel an existing DM-MS registration, it shall send a DM-GREGISTER CANCEL PDU addressed to the DM-MS. It shall then await GMA-REPORT indication(s) from layer 2, reporting on the progress of the transmission:

- If the gateway receives a GMA-REPORT indication reporting failure because the channel has become busy, it shall retry when the channel has become free.
- If the gateway receives a GMA-REPORT indication reporting that the DM-GREGISTER CANCEL PDU has been transmitted the appropriate number of times, the gateway shall start timer DT375 and await a response from the addressed DM-MS:
 - If it receives a DM-GCANCEL ACK PDU then it shall stop timer DT375 (and regard the registration as cancelled).
 - If timer DT375 expires then the gateway shall either send the DM-GREGISTER CANCEL PDU again or otherwise shall regard the DM-MS registration as cancelled. The gateway shall attempt the registration cancellation transmission up to a maximum of DN375 times if no response has been received.

NOTE: The gateway may choose to delay re-sending the DM-GREGISTER CANCEL PDU after timer DT375 expires in case there may be a temporary propagation problem.

10.3.5 Procedures for U-MM STATUS and D-MM STATUS

10.3.5.1 Procedures for sending U-MM STATUS

The gateway sends the U-MM STATUS PDU to the SwMI if it wishes to request to start or continue operation as a DM gateway, to send a list of DM-MS individual addresses, to modify or replace the current list of DM-MS individual addresses or to stop operating as a DM gateway; see annex B.

The gateway shall send the U-MM STATUS PDU containing the "status uplink" element set appropriately, and including a list of DM-MS individual addresses if appropriate. (If wishing to send more than 15 DM-MS addresses, the gateway needs to send more than one U-MM STATUS PDU). The PDU shall have PDU priority 3. The gateway shall start timer T352 and wait for a response:

- If the gateway receives a D-MM STATUS PDU responding to its request then it shall stop timer T352 and take appropriate action depending on the "status downlink" element value. For example:
 - If the gateway requested to start or continue operation as a DM gateway, and the SwMI rejects that request, then the gateway shall not include DM-MS individual addresses within TMO PDUs and shall cancel or otherwise render invalid existing DM-MS registrations. However it may conduct the DM procedures defined in clause 10.3.2.
 - If the gateway requested to continue operation as a DM gateway, and the SwMI indicates that it does not have a DM-MS address set for this gateway, then the gateway may send another U-MM STATUS PDU containing DM-MS addresses (using the request to replace the current DM-MS address set (if any)).
 - If the gateway sent a list of DM-MS addresses, and the SwMI rejected some of those DM-MSs, then the gateway shall cancel the appropriate DM-MS registrations.
- If timer T352 expires then the gateway may either send the U-MM STATUS PDU again or take appropriate action (e.g. cancelling DM-MS registrations if appropriate).

10.3.5.2 Procedures for receiving D-MM STATUS

The gateway may receive an unsolicited D-MM STATUS PDU from the SwMI relating to its DM gateway operation. It shall perform the appropriate procedure as follows:

- If the gateway receives a D-MM STATUS PDU with status downlink "Command to remove DM-MS addresses" removing some of the DM-MSs from the current DM-MS address set, it shall send a U-MM STATUS PDU with status uplink "Acceptance to removal of DM-MS addresses" accepting the command. It shall then cancel the appropriate DM-MS registrations.
- If the gateway receives a D-MM STATUS PDU with status downlink "Command to change registration label" commanding it to change the registration label, it shall send a U-MM STATUS PDU with status uplink "Acceptance to change registration label" accepting the command and shall use a different registration label when it next sends the presence signal.
- If the gateway receives a D-MM STATUS PDU with status downlink "Command to stop DM gateway operation" commanding it to stop operating as a DM gateway, it shall send a U-MM STATUS PDU with status uplink "Acceptance to stop DM gateway operation" accepting the command. It shall stop including DM-MS individual addresses within TMO PDUs and shall cancel or otherwise render invalid existing DM-MS registrations. However it may continue to conduct the DM procedures defined in clause 10.3.2.

11 Gateway U-plane converter

11.1 Introduction

This clause describes the U-plane converter in the gateway.

The U-plane converter performs the transfer of U-plane traffic and U-plane signalling between the DM and TMO sides of the gateway's protocol stack. It performs the transfer by conducting a conversion between the DM and TMO U-plane primitives i.e. it converts between primitives at the GMD-SAP and primitives at the TMD-SAP.

The gateway may perform channel decoding (and re-encoding) of received traffic, allowing error correction to be performed before re-transmission on the other side.

NOTE: Channel decoding and re-encoding of traffic (other than TCH/7,2) is necessary if the traffic is air interface encrypted. If the traffic is not air interface encrypted then the gateway may choose whether to decode and re-encode the traffic. Note that the error performance may be improved if the gateway decodes and re-encodes the traffic.

If the gateway does not perform channel decoding and re-encoding of the traffic then, for the purposes of the U-plane conversion, the gateway may treat the traffic as if it had been TCH/7,2. However in all cases STCH shall be decoded (and U-plane signalling re-encoded). The timing and ordering and half-slot pairing of the U-plane information – signalling and TCH – shall be preserved.

The U-plane converter is defined to clarify the protocol description. It does not imply any specific gateway implementation. The internal boundaries described between the U-plane converter and the gateway's DM layer 2 and TMO layer 2 are not testable, but are rather used for the description of the protocol model. In the following clauses the word "shall" is used with service primitives and parameters for traceability reasons in the protocol model, but those primitives are not testable.

11.2 Start of call transaction

11.2.1 Call transaction from DMO to TMO

When the gateway's TMO MAC has been authorized to transmit traffic on the TMO side, and has established whether it will steal the first half slot for C-plane signalling, it issues a TMD-REPORT indication to the U-plane converter indicating the initial half slot synchronization. If the U-plane converter is not yet receiving U-plane information on the DMO side then it shall issue TMD-UNITDATA request primitives with the "stolen indication" parameter set to "C-plane stealing required". When the U-plane converter starts to receive U-plane information on the DMO side, it shall align the half slot positions used for transmitting traffic and U-plane signalling on the TMO side with those received on the DMO side (requesting an additional C-plane stealing half slot if necessary).

NOTE: Value "C-plane stealing required" for parameter "stolen indication" in the TMD-UNITDATA request primitive is an additional value of stolen indication not needed for a normal TM-MS. It is used by the U-plane converter to request the TMO MAC to fill a half slot with C-plane stealing during a call transaction, in cases when the U-plane converter does not have any U-plane information to send. See also clause 17.4.

11.2.2 Call transaction from TMO to DMO

When the gateway's DM layer 2 is ready to transmit traffic on the DMO side, and has established whether it will steal the first half slot for C-plane signalling, it issues a GMD-REPORT indication to the U-plane converter indicating the initial half slot synchronization. If the U-plane converter is not yet receiving U-plane information on the TMO side then it shall issue GMD-UNITDATA request primitives with the "stolen indication" parameter set to "C-plane stealing required". When the U-plane converter starts to receive U-plane information on the TMO side, it shall align the half slot positions used for transmitting traffic and U-plane signalling on the DMO side with those received on the TMO side (requesting an additional C-plane stealing half slot if necessary).

If the U-plane converter starts to receive U-plane information on the TMO side before DM layer 2 has indicated that it is ready to transmit traffic on the DMO side then the U-plane converter shall either discard the received U-plane information or store it until it can be sent.

11.3 U-plane conversion during call transaction

11.3.1 U-plane conversion from DMO to TMO

This clause defines the U-plane conversion when the gateway is receiving traffic and/or STCH on the DMO side. The gateway's DM layer 2 issues GMD-UNITDATA indications as defined in clause 13.6.4.2. For each received GMD-UNITDATA indication, the U-plane converter shall generate a TMD-UNITDATA request as follows:

- 1) The half slot content shall be the same as in the GMD-UNITDATA indication.
- 2) The half slot position shall be the same as in the GMD-UNITDATA indication.
- 3) If the stolen indication was set to "stolen for C-plane signalling" in the GMD-UNITDATA indication then it shall be set to "C-plane stealing required" in the TMD-UNITDATA request. (This procedure does not apply in the case of protected circuit mode data with interleaving depth $N = 4$ or 8 or for $N = 1$ if only one half slot was stolen).

If the stolen indication was set to "stolen for U-plane signalling" in the GMD-UNITDATA indication then it shall be set to "stolen for U-plane signalling" in the TMD-UNITDATA request.

If the stolen indication was set to "not stolen" in the GMD-UNITDATA indication then:

- a) if the half slot condition was set to "good" then the stolen indication shall be set to "not stolen" in the TMD-UNITDATA request;
- b) if the half slot condition was not set to "good" but the DM layer 2 provided the received data then the stolen indication shall be set to "not stolen" in the TMD-UNITDATA request;

- c) if the half slot condition was not set to "good" and the DM layer 2 did not provide the received data then the gateway designer should use an appropriate method for filling the corresponding TMO half slot (e.g. setting the stolen indication to "C-plane stealing required" in the TMD-UNITDATA request).

NOTE 1: For the purposes of the protocol description it is assumed that DM layer 2 always provides data to the U-plane converter for $N = 4$ and 8 . The same assumption is made for $N = 1$ if one half slot was stolen. So procedure c) does not apply in these cases. In an implementation, the gateway designer may choose to use other appropriate methods when the data is not decoded successfully.

Refer also to EN 300 392-2 [5], clause 23.8.3.

The order in which the TMD-UNITDATA requests are generated shall be the same as the order in which the GMD-UNITDATA indications were received from the DM layer 2.

NOTE 2: The above paragraph assumes that, if the gateway is decoding and re-encoding the traffic then, in the case of U-plane stealing from circuit mode data with $N = 4$ or 8 , the DM layer 2 has delayed the issuing of the GMD-UNITDATA indication(s) containing the U-plane signalling data by $N - 1$ traffic frames (see clause 13.6.4.2). If the DM layer 2 has not performed this function then the U-plane converter needs to delay the U-plane signalling. This is so that the gateway transmits the U-plane data stream with the U-plane signalling in the same position as when the master DM-MS transmitted it.

11.3.2 U-plane conversion from TMO to DM

This clause defines the U-plane conversion when the gateway is receiving traffic and/or STCH on the TMO side. The gateway's TMO MAC issues TMD-UNITDATA indications as defined in EN 300 392-2 [5], clause 23.8.3.2. For each received TMD-UNITDATA indication, the U-plane converter shall generate a GMD-UNITDATA request as follows:

- 1) The half slot content shall be the same as in the TMD-UNITDATA indication.
- 2) The half slot position shall be the same as in the TMD-UNITDATA indication.
- 3) If the stolen indication was set to "stolen for C-plane signalling" in the TMD-UNITDATA indication then it shall be set to "C-plane stealing required" in the GMD-UNITDATA request. (This procedure does not apply in the case of protected circuit mode data with interleaving depth $N = 4$ or 8 or for $N = 1$ if only one half slot was stolen).

If the stolen indication was set to "stolen for U-plane signalling" in the TMD-UNITDATA indication then it shall be set to "stolen for U-plane signalling" in the GMD-UNITDATA request.

If the stolen indication was set to "not stolen" in the TMD-UNITDATA indication then:

- a) if the half slot condition was set to "good" then the stolen indication shall be set to "not stolen" in the GMD-UNITDATA request;
- b) if the half slot condition was not set to "good" but the TMO MAC provided the received data then the stolen indication shall be set to "not stolen" in the GMD-UNITDATA request;
- c) if the half slot condition was not set to "good" and the TMO MAC did not provide the received data then the gateway designer should use an appropriate method for filling the corresponding DM half slot (e.g. setting the stolen indication to "C-plane stealing required" in the GMD-UNITDATA request).

NOTE 1: For the purposes of the protocol description it is assumed that the TMO MAC always provides data to the U-plane converter for $N = 4$ and 8 . The same assumption is made for $N = 1$ if one half slot was stolen. So procedure c) does not apply in these cases. In an implementation, the gateway designer may choose to use other appropriate methods when the data is not decoded successfully.

The order in which the GMD-UNITDATA requests are generated shall be the same as the order in which the TMD-UNITDATA indications were received from the TMO MAC.

NOTE 2: The above paragraph assumes that, if the gateway is decoding and re-encoding the traffic then, in the case of U-plane stealing from circuit mode data with $N = 4$ or 8 , the TMO MAC has delayed the issuing of the TMD-UNITDATA indication(s) containing the U-plane signalling data by $N - 1$ traffic frames (see clause 17.4). If the TMO MAC has not performed this function then the U-plane converter needs to delay the U-plane signalling.

11.4 Stopping transmission/reception

11.4.1 Call transaction from DMO to TMO

If TMO traffic transmit authorization is withdrawn when the U-plane converter is still receiving U-plane information on the DMO side then the U-plane converter shall discard the received information.

If the U-plane converter stops receiving U-plane information on the DMO side when the gateway still has TMO traffic transmit authorization then the U-plane converter shall stop issuing TMD-UNITDATA request primitives to the TMO MAC. (The TMO MAC will then transmit as required, sending tail bits for $N = 4$ and 8 , and then filling half slots with C-plane stealing if appropriate; see clause 17.4).

11.4.2 Call transaction from TMO to DMO

If traffic transmission has stopped on the DMO side but the U-plane converter is still receiving U-plane information on the TMO side then the U-plane converter shall discard the received information.

If the U-plane converter stops receiving U-plane information on the TMO side when the gateway is still transmitting traffic on the DMO side then the U-plane converter shall stop issuing GMD-UNITDATA request primitives to the DM layer 2. (The DM layer 2 will then transmit as required, sending tail bits for $N = 4$ and 8 , and then sending C-plane signalling; see clause 13.6.5.2).

12 Gateway DM layer 2 service description

12.1 Introduction

The following clauses describe the services offered by the gateway's layer 2 on the DMO side. The service description is described in terms of Service Access Points (SAPs), primitives and their parameters.

The internal boundaries between the layers and sub-layers described herein are not testable and do not imply any specific implementation, but are rather used for the description of the protocol model. In the following clauses the word "shall" is used with SAPs, service primitives and parameters for traceability reasons in the protocol model, but again those SAPs and primitives are not testable. The following description also does not imply any specific implementation.

NOTE: In an implementation, additional parameters may be included in the primitives in order to exchange additional information between layer 3 and layer 2.

12.2 Gateway DM layer 2 architecture

The gateway's DM layer 2 – the Data Link Layer (DLL) – comprises two sub-layers. These both perform Medium Access Control (MAC) functions and they are referred to as the upper MAC and lower MAC. The lower MAC performs channel coding and interleaving, and the upper MAC performs other layer 2 protocol functions. The services offered by layer 2 to layer 3 are described in the following clauses.

In the protocol model, the gateway's DM layer 2 shall provide services to layer 3 through SAPs supporting different functions. The GMA-SAP is used for all C-plane signalling messages and the GMC-SAP is used for layer management, status and configuration.

The gateway's DM layer 2 shall provide U-plane services through the GMD-SAP, which is used to support traffic transmission and reception in circuit mode; see also clause 11. In circuit mode, some traffic capacity may be stolen for signalling purposes. This may be either for C-plane signalling (GMA-SAP) or U-plane signalling (GMD-SAP).

A virtual SAP, the GMV-SAP, is defined within layer 2, between the upper MAC and lower MAC, to allow a protocol description using primitives and logical channels. The selection of a specific logical channel triggers specific channel coding at the lower MAC. The GMV-SAP primitives are described in clause 13.

The GP-SAP is used for communication between the MAC and the physical layer. To exchange information at the GP-SAP, pre-formed subslots and blocks with burst type indication are used.

12.2.1 Lower layer management in layer 2

A lower layer management entity may be incorporated into all lower layers, accessible via GxC-SAPs. These SAPs enable access to information such as measured values, status and general information.

12.3 Service descriptions

12.3.1 Services at the GMA-SAP

12.3.1.1 Services provided to layer 3

The procedures defined for a DM-MS in EN 300 396-3 [3], clause 7.3.1.1 shall apply also for a gateway, except that references to the DMA-SAP, DMA-UNITDATA request, DMA-UNITDATA indication and DMA-REPORT indication shall be replaced by GMA-SAP, GMA-UNITDATA request, GMA-UNITDATA indication and GMA-REPORT indication respectively.

NOTE: Clause 13.5.2 defines when the gateway's DM layer 2 may deliver a received message to layer 3.

12.3.1.1.1 Protocol control function for delivery of received message

When the gateway's DM layer 2 receives a message with appropriate addressing (see note above), it delivers the message to layer 3 in a GMA-UNITDATA indication primitive. The gateway shall use the "message type" and "gateway message subtype" parameters, and its current state, to decide whether the message should be routed to its layer 3 call control or mobility management entity:

- DM-GREGISTER REQUEST and DM-GCANCEL ACK messages shall be routed to the mobility management entity.
- When the gateway is active in a registration phase, DM-PREEMPT messages shall be routed to the mobility management entity. At all other times, DM-PREEMPT messages shall be routed to the call control entity.
- All other recognizable messages shall be routed to the call control entity.

12.3.1.2 Service primitives at the GMA-SAP

12.3.1.2.1 GMA-REPORT primitive

The specifications defined for a DM-MS in EN 300 396-3 [3], clause 7.3.1.2.1 shall apply also for a gateway, except that references to the DMA-UNITDATA request and DMA-REPORT indication primitives shall be replaced by GMA-UNITDATA request and GMA-REPORT indication respectively.

12.3.1.2.2 GMA-UNITDATA primitive

The specifications defined for a DM-MS in EN 300 396-3 [3], clause 7.3.1.2.2 shall apply also for a gateway, with the following differences:

- i) References to the DMA-UNITDATA request and DMA-UNITDATA indication primitives shall be replaced by GMA-UNITDATA request and GMA-UNITDATA indication respectively.
- ii) The GMA-UNITDATA primitive shall have the following additional parameters:
 - parameter "gateway message subtype": conditional in both request and indication;
 - parameter "type of registration request": conditional in both request and indication;
 - parameter "incomplete DM-GSETUP received": not used in request, conditional in indication.
- iii) The destination address parameter shall be conditional in the GMA-UNITDATA indication. (It is not included for reception of gateway-specific messages).

- iv) Parameters "changeover request held during occupation", "recent user changeover request" and "DM channel" are not used.

12.3.2 Services at the GMC-SAP

12.3.2.1 Services provided to layer 3

The GMC-SAP is used for the transfer of local layer management information. It may be used, for example, for layer 3 to instruct layer 2 to reconfigure its parameters. It is also used for layer 2 to issue reports on the perceived state of the channel, enabling correct behaviour of layer 3.

12.3.2.2 Service primitives at the GMC-SAP

12.3.2.2.1 GMC-CONFIGURE primitive

The GMC-CONFIGURE request shall be used for layer 3 to set up and configure the lower layers.

In the protocol model this primitive is used for layer 3 to supply appropriate parameters needed in the gateway presence signal. It is also used when layer 3 wishes to instruct layer 2 to announce or terminate a registration phase.

The parameters shall be defined as follows.

Table 3: Parameters for the GMC-CONFIGURE primitive

Parameter	Request
Gateway address	C
Presence signal information	C
Circuit mode information	C
State change information	C
Reservation extension information	C
Channel selection information	C

12.3.2.2.2 GMC-REPORT primitive

The specifications defined for a DM-MS in EN 300 396-3 [3], clause 7.3.2.2.2 shall apply also for a gateway, except that references to the DMC-REPORT shall be replaced by GMC-REPORT and parameter "DM channel" is not used.

12.3.3 Services at the GMD-SAP

12.3.3.1 Services provided to the U-plane converter

The GMD-SAP shall provide the interface between the gateway's DM layer 2 and the U-plane converter. It shall be used for the transfer of speech frames or circuit mode data. It shall also be used for the transfer of U-plane signalling messages sent or received by stealing from the traffic capacity.

The primitives at the GMD-SAP are the GMD-UNITDATA request/indication and GMD-REPORT indication.

12.3.3.2 Service primitives at the GMD-SAP

12.3.3.2.1 GMD-REPORT primitive

The specifications defined for a DM-MS in EN 300 396-3 [3], clause 7.3.3.2.1 shall apply also for a gateway, with the following differences:

- i) References to the DMD-REPORT indication and DMD-UNITDATA request primitives shall be replaced by GMD-REPORT indication and GMD-UNITDATA request respectively.
- ii) References to the U-plane application shall be replaced by U-plane converter.

- iii) Parameter "DM channel" is not used.

12.3.3.2.2 GMD-UNITDATA primitive

The specifications defined for a DM-MS in EN 300 396-3 [3], clause 7.3.3.2.2 shall apply also for a gateway, with the following differences:

- i) References to the DMD-UNITDATA request and DMD-UNITDATA indication primitives shall be replaced by GMD-UNITDATA request and GMD-UNITDATA indication respectively.
- ii) Parameters "half slot importance" and "DM channel" are not used.

12.4 Parameter listing

The definitions given for a DM-MS in EN 300 396-3 [3], clause 7.4 shall apply also for a gateway, with the following differences:

- i) References to the DMA-SAP shall be replaced by GMA-SAP.
- ii) References to the U-plane application shall be replaced by U-plane converter.
- iii) Parameters "call release", "changeover request held during occupation", "DM channel", "half slot importance", "recent user changeover request" and "valid addresses" are not used.
- iv) Parameter "priority of ongoing call" may also be used when the DM channel is in use for another gateway's registration phase, enabling layer 3 to decide whether pre-emption is valid.
- v) Parameter "stolen indication" may be used to request layer 2 to fill a half slot with C-plane signalling.

The following definitions shall also apply:

Gateway address

This parameter in the GMC-CONFIGURE request primitive configures layer 2 with the 10-bit gateway address.

Gateway message subtype

This parameter is used in the GMA-UNITDATA request primitive for layer 3 to specify, for a gateway-specific message, the subtype of the PDU to be sent. Layer 2 shall include the gateway message subtype when it constructs the message.

This parameter is also used in the GMA-UNITDATA indication primitive for layer 2 to indicate to layer 3 the message subtype for a received gateway-specific message.

Incomplete DM-GSETUP received

This parameter is used in the GMA-UNITDATA indication primitive for layer 2 to indicate to layer 3 that an incomplete DM-GSETUP message has been received.

Presence signal information

This parameter is used in the GMC-CONFIGURE request primitive for layer 3 to provide appropriate information needed for the construction of the gateway presence signal. It is also used for layer 3 to specify when it wishes layer 2 to announce or terminate a registration phase.

Reservation extension information

This parameter is used in the GMC-CONFIGURE request primitive for layer 3 to instruct layer 2 to extend the current reservation period.

State change information

This parameter is used in the GMC-CONFIGURE request primitive for layer 3 to inform layer 2 that it requires a DM state change. For example, it may be used for layer 3 to indicate a return to channel reservation; or it may be used if layer 3 has decided to leave a call without further signalling.

NOTE: As usual, the GMC-REPORT indication primitive is used when layer 2 reports state changes to layer 3.

Type of registration request

This parameter is used in the GMA-UNITDATA indication primitive for layer 2 to indicate the type of registration request to layer 3 when it delivers a received DM-GREGISTER REQUEST message.

This parameter is also used in the GMA-UNITDATA request primitive for layer 3 to specify, for a DM-GREGISTER ACCEPT or DM-GREGISTER REJECT message, whether the related registration request was solicited or unsolicited. Layer 2 shall then include the parameter as a message-dependent element when it constructs the message.

13 Gateway DM layer 2 protocol

13.1 Introduction

The following clauses describe the operation of the DM layer 2 in a gateway – either a DM-GATE, type 1A DM-REP/GATE or type 1B DM-REP/GATE.

NOTE 1: The operation of the TMO layer 2 in the gateway is described in clause 17.

NOTE 2: For a DM-GATE or type 1A DM-REP/GATE, all DM transmissions are sent on the selected DM RF carrier.

The procedures for a type 1B DM-REP/GATE are similar to the procedures for a type 1A DM-REP/GATE except that transmissions by DM-MSs are sent on the appropriate DM "uplink" RF carrier f_1 and transmissions from the DM-REP/GATE to DM-MSs are sent on the associated (duplex-spaced) DM "downlink" RF carrier f_2 .

A DM-GATE or type 1A DM-REP/GATE can support a single call on the selected DM RF carrier. A type 1B DM-REP/GATE can support only a single call on the pair of DM RF carriers (f_1 and f_2).

NOTE 3: This clause defines only the procedures specific to the gateway functions. (If the gateway has a handset attached then the equipment is in essence a combined gateway and terminating mobile).

The gateway's DM layer 2 is divided into two sub-layers: the upper MAC and the lower MAC.

13.1.1 Functions of lower MAC

The lower MAC in the gateway provides the following services to the upper MAC:

- transfer of MAC PDUs into suitable physical layer bursts in accordance with the appropriate timeslot;
- choice of preamble and training sequence corresponding to the slot flag value and vice versa;
- channel signal strength measurement (RSSI);
- channel coding and scrambling:
 - Cyclic Redundancy Check (CRC) calculation;
 - forward error correction and interleaving of MAC blocks;
 - scrambling and de-scrambling of MAC blocks.

See clause 16 for specific details of the lower MAC functionality.

13.1.2 Functions of upper MAC

The principal functions of the upper MAC in a gateway (DM-GATE or DM-REP/GATE) are as follows:

- transmission on the DM channel of messages issued by layer 3;

- reception of messages from DM-MSs, and delivery of appropriate messages to layer 3;
- the DM random access procedures (contention control);
- DM fragmentation of long messages received from layer 3;
- transmission and reception of U-plane traffic and U-plane signalling on the DM channel;
- stealing from the DM traffic channel capacity, when required, to send signalling messages;
- management of DM layer 2 addressing;
- application and control of DM air interface encryption if appropriate;
- maintaining the frame and multiframe structure;
- determination of the DM channel state;
- providing synchronization for the DM channel;
- transmission of the gateway presence signal.

A DM-REP/GATE has the following additional functions, though these apply only during those transactions in which a DM-MS is master of the DM channel:

- reception of signalling messages from the master DM-MS, on the master link, and regeneration and re-transmission of the received message on the slave link;
- reception of traffic from the master DM-MS, on the master link, and re-transmission of that traffic on the slave link;
- reception of pre-emption messages from slave DM-MSs, on the slave link, and regeneration and re-transmission of the received message on the master link.

The functions of the upper MAC in the gateway are described in this clause.

13.2 Interface between lower and upper MAC

The procedures defined for a DM-MS in EN 300 396-3 [3], clause 8.2 shall apply also for a gateway, with the following differences:

- i) References to the DMV-SAP, and the DMV-UNITDATA request and indication primitives, shall be replaced by GMV-SAP and GMV-UNITDATA request and indication primitives.
- ii) References to the DMA-SAP and DMA-primitives shall be replaced by GMA-SAP and GMA-primitives; references to the DMD-SAP and DMD-primitives shall be replaced by GMD-SAP and GMD-primitives; and references to the DMC-REPORT shall be replaced by GMC-REPORT.
- iii) Information at the GMD-SAP shall be passed to and from the U-plane converter.
- iv) Clause 8.2.4 (scrambling mechanism) shall be replaced by the definition given in clause 8.2.4 of the present document.

NOTE: The scrambling mechanism for SCH/F, STCH and TCH is based on the "gateway address" element and the layer 2 "source address" element from the appropriate DMAC-SYNC PDU, as defined in clause 8.2.4.

For a DM-REP/GATE re-transmitting a DM message locally, the "source address" element contains the SSI or pseudo SSI of the DM-MS that originated the message. This colour code applies both when the DM-REP/GATE receives on one link (i.e. master link or slave link) and then again when it re-transmits on the other link (i.e. slave link or master link respectively).

- v) In clause 8.2.6.1.1, "Idle mode" for the gateway shall be defined as follows:
- The gateway shall operate in idle mode when it is not currently involved in a call. The gateway in idle mode shall monitor the appropriate DM RF channel in order to determine the current state of the channel and to receive any new signalling messages addressed to itself (i.e. with its address as the 10-bit "gateway address" element in the DMAC-SYNC PDU).

13.3 Basic capabilities of the gateway physical layer

The gateway's physical layer shall have at least the following basic capabilities.

13.3.1 DM-GATE capabilities

NOTE 1: The capabilities defined in this clause are suitable if the DM-GATE synchronizes the DM channel timing to the appropriate TM channel timing as defined in clause 13.4.1.1 so that the DM slot numbering lags three timeslot durations behind the TM downlink slot. These channel timings impose the minimum requirements on the DM-GATE's physical layer.

A DM-GATE shall be capable of either transmitting or receiving (i.e. simplex mode operation) on a single DM RF carrier. It shall also be capable of either receiving on a TM downlink RF carrier (the downlink from the SwMI to TM-MSs) or transmitting on the associated TM uplink RF carrier (the uplink from TM-MSs to the SwMI), using frequency half duplex operation i.e. two-frequency simplex mode.

The DM-GATE is not required to be able to transmit or receive on any one of the RF carriers at the same time as it is either transmitting or receiving on one of the other RF carriers.

NOTE 2: In case of conflicting requirements to transmit or receive in a timeslot on both the TMO and DMO sides of the gateway, the TMO requirements may override the DM transmission and monitoring requirements defined in this clause.

The DM-GATE shall be capable of performing the following switching functions between contiguous timeslots i.e. within the guard + ramping + PA linearization time:

- a) from DM transmit to TM transmit or TM receive;
- b) from DM receive to TM transmit or TM receive;
- c) from TM transmit to DM transmit or DM receive;
- d) from TM receive to DM transmit or DM receive.

The DM-GATE should also be capable of switching from DM transmit to DM receive, and from DM receive to DM transmit, between contiguous timeslots i.e. within the guard + ramping + PA linearization time.

NOTE 3: These timing requirements apply only to the actual switching. The DM-GATE is not required to be able to decode and process a message between contiguous slots. When the DM-GATE switches from receive to transmit between contiguous slots, the message to be transmitted was received by the DM-GATE at least one slot earlier.

The DM-GATE shall be capable of switching from TM transmit to TM receive, and from TM receive to TM transmit, within one timeslot duration.

The DM-GATE shall be capable of transmitting in all four timeslots of at least four consecutive DM frames.

13.3.2 Type 1A DM-REP/GATE capabilities

A type 1A DM-REP/GATE shall be capable of either transmitting or receiving (i.e. simplex mode operation) on a single DM RF carrier. It shall also be capable of either receiving on a TM downlink RF carrier or transmitting on the associated TM uplink RF carrier, using frequency half duplex operation i.e. two-frequency simplex mode.

The DM-REP/GATE shall be capable of switching from TM transmit to TM receive, and from TM receive to TM transmit, within one timeslot duration.

The DM-REP/GATE shall be capable of performing all the other switching functions between contiguous timeslots i.e. within the guard + ramping + PA linearization time. This includes switching from DM transmit to DM receive and from DM receive to DM transmit, and all switching functions between DM and TM.

NOTE: This timing requirement applies only to the actual switching. The DM-REP/GATE is not required to be able to decode and process a message between contiguous timeslots.

The DM-REP/GATE shall be capable of transmitting in all four timeslots of at least four consecutive DM frames.

The DM-REP/GATE shall also be capable of performing the functions defined in the appropriate clause below.

13.3.2.1 Type 1A DM-REP/GATE: DM RF carrier in same sub-band as TM downlink carrier

NOTE 1: This clause may be appropriate also when the DM RF carrier is within e.g. 2,5 MHz of the sub-band containing the TM downlink RF carrier.

The DM-REP/GATE shall be capable of receiving on the DM RF carrier at the same time as it is receiving on the TM downlink RF carrier. It shall be capable of transmitting on the DM RF carrier at the same time as it is transmitting on the TM uplink RF carrier. It shall also be capable of receiving on the DM RF carrier at the same time as it is transmitting on the TM uplink RF carrier.

The DM-REP/GATE is not required to be capable of receiving on the TM downlink RF carrier at the same time as it is transmitting on the DM RF carrier.

NOTE 2: In case of conflicting requirements to transmit on the DM RF carrier and receive the TM downlink RF carrier, the TMO reception requirement may override the DM transmission requirements defined in this clause.

13.3.2.2 Type 1A DM-REP/GATE: DM RF carrier in same sub-band as TM uplink carrier

NOTE 1: This clause may be appropriate also when the DM RF carrier is within e.g. 2,5 MHz of the sub-band containing the TM uplink RF carrier.

The DM-REP/GATE shall be capable of receiving on the DM RF carrier at the same time as it is receiving on the TM downlink RF carrier. It shall be capable of transmitting on the DM RF carrier at the same time as it is transmitting on the TM uplink RF carrier. It shall also be capable of receiving on the TM downlink RF carrier at the same time as it is transmitting on the DM RF carrier.

The DM-REP/GATE is not required to be capable of receiving on the DM RF carrier at the same time as it is transmitting on the TM uplink RF carrier.

NOTE 2: In case of conflicting requirements to receive on the DM RF carrier and transmit on the TM uplink RF carrier, the TMO transmission requirement may override the DM reception requirements defined in this clause.

13.3.2.3 Type 1A DM-REP/GATE: DM RF carrier not in either TMO sub-band

NOTE 1: If the DM RF carrier is close to either TMO sub-band (e.g. within 2,5 MHz) then clauses 13.3.2.1 or 13.3.2.2 may be more appropriate.

NOTE 2: The capabilities defined in this clause are suitable if the DM-REP/GATE synchronizes the DM channel timing to the appropriate TM channel timing as defined in clause 13.4.1.2.3 so that the DM slave link slot numbering lags five timeslot durations behind the TM downlink slot. These channel timings generally impose the minimum requirements on the DM-REP/GATE's physical layer.

Alternatively the DM-REP/GATE could use a different DM channel timing (e.g. that defined in clauses 13.4.1.2.1 or 13.4.1.2.2). However it would then also need to be able to transmit on both the DM RF carrier and the TM uplink RF carrier at the same time.

The DM-REP/GATE shall be capable of receiving on the DM RF carrier at the same time as it is receiving on the TM downlink RF carrier. It shall also be capable of receiving on the TM downlink RF carrier at the same time as it is transmitting on the DM RF carrier, and of receiving on the DM RF carrier at the same time as it is transmitting on the TM uplink RF carrier.

The DM-REP/GATE is not required to be capable of transmitting on both the DM RF carrier and the TM uplink RF carrier at the same time.

NOTE 3: In case of conflicting requirements to transmit at the same time on both the TMO and DMO sides of the gateway, the TMO transmission requirement may override the DM transmission requirements defined in this clause.

13.3.3 Type 1B DM-REP/GATE capabilities

A type 1B DM-REP/GATE shall be capable of either transmitting on one DM RF carrier (the selected downlink frequency f_2 from the DM-REP/GATE to DM-MSs) or receiving on a different DM RF carrier (the associated uplink frequency f_1 from DM-MSs to the DM-REP/GATE), using frequency half duplex operation i.e. two-frequency simplex mode. The DM-REP/GATE shall also be capable of either receiving on a TM downlink RF carrier or transmitting on the associated TM uplink RF carrier, using frequency half duplex operation.

The DM-REP/GATE shall be capable of switching from TM transmit to TM receive, and from TM receive to TM transmit, within one timeslot duration.

The DM-REP/GATE shall be capable of performing all the other switching functions between contiguous timeslots i.e. within the guard + ramping + PA linearization time. This includes switching from DM transmit to DM receive and from DM receive to DM transmit, and all switching functions between DM and TM.

NOTE: This timing requirement applies only to the actual switching. The DM-REP/GATE is not required to be able to decode and process a message between contiguous timeslots.

The DM-REP/GATE shall be capable of transmitting in all four timeslots of at least four consecutive DM frames.

The DM-REP/GATE shall also be capable of performing the functions defined in the appropriate clause below.

13.3.3.1 Type 1B DM-REP/GATE: frequency usage method 1

The capabilities defined in this clause assume that the DM RF carriers are used in such a way that the DM uplink RF carrier f_1 from DM-MSs to the DM-REP/GATE is not in the same sub-band as the TM uplink RF carrier from TM-MSs to the SwMI, and the DM downlink RF carrier f_2 from the DM-REP/GATE to DM-MSs is not in the same sub-band as the TM downlink RF carrier from the SwMI to TM-MSs.

NOTE 1: For example, this may be achieved if DM uplink RF carrier f_1 is in the same sub-band as the TM downlink RF carrier and DM downlink RF carrier f_2 is in the same sub-band as the TM uplink RF carrier. So, if the TMO system uses normal carrier operation, with the TM uplink RF carrier below the TM downlink RF carrier, then the DM uplink RF carrier f_1 is above the DM downlink RF carrier f_2 .

NOTE 2: The capabilities defined in this clause are suitable if the DM-REP/GATE synchronizes the DM channel timing to the appropriate TM channel timing as defined in clause 13.4.1.2.3 so that the DM slave link slot numbering lags five timeslot durations behind the TM downlink slot. These channel timings generally impose the minimum requirements on the DM-REP/GATE's physical layer.

Alternatively the DM-REP/GATE could use a different DM channel timing (e.g. that defined in clauses 13.4.1.2.1 or 13.4.1.2.2). However it would then also need to be able to transmit on both DM downlink RF carrier f_2 and the TM uplink RF carrier at the same time.

The DM-REP/GATE shall be capable of receiving on DM uplink RF carrier f_1 at the same time as it is receiving on the TM downlink RF carrier. It shall also be capable of receiving on the TM downlink RF carrier at the same time as it is transmitting on DM downlink RF carrier f_2 , and of receiving on DM uplink RF carrier f_1 at the same time as it is transmitting on the uplink RF carrier.

The DM-REP/GATE is not required to be capable of transmitting on both DM downlink RF carrier f_2 and the TM uplink RF carrier at the same time.

NOTE 3: In case of conflicting requirements to transmit at the same time on both the TMO and DMO sides of the gateway, the TM transmission requirement may override the DM transmission requirements defined in this clause.

13.3.3.2 Type 1B DM-REP/GATE: frequency usage method 2

The capabilities defined in this clause assume that the DM RF carriers are used in such a way that the DM uplink RF carrier f_1 from DM-MSs to the DM-REP/GATE is in the same sub-band as the TM uplink RF carrier from TM-MSs to the SwMI, and the DM downlink RF carrier f_2 from the DM-REP/GATE to DM-MSs is in the same sub-band as the TM downlink RF carrier from the SwMI to TM MSs.

NOTE 1: So, if the TMO system uses normal carrier operation, with the TM uplink RF carrier below the TM downlink RF carrier, then the DM uplink RF carrier f_1 is below the DM downlink RF carrier f_2 .

NOTE 2: This method of frequency usage may result in some degradation of the DMO channel maintenance procedures compared with frequency usage method 1. It also requires the DM-REP/GATE to be capable of transmitting on both DM downlink RF carrier f_2 and the TM uplink RF carrier at the same time. However it may reduce the risk of interference to SwMI reception relative to the usage indicated in note 1 of clause 13.3.3.1, since the risk of interference from DM-MSs may be less than the risk of interference from a DM-REP/GATE.

NOTE 3: This clause may be appropriate also when the DM uplink RF carrier f_1 is within e.g. 2,5 MHz of the sub-band containing the TM uplink RF carrier or the DM downlink RF carrier f_2 is within e.g. 2,5 MHz of the sub-band containing the TM downlink RF carrier.

The DM-REP/GATE shall be capable of receiving on the DM uplink RF carrier f_1 at the same time as it is receiving on the TM downlink RF carrier. It shall also be capable of transmitting on the DM downlink RF carrier f_2 at the same time as it is transmitting on the TM uplink RF carrier.

The DM-REP/GATE is not required to be capable of receiving on the DM uplink RF carrier f_1 at the same time as it is transmitting on the TM uplink RF carrier. Also, it is not required to be capable of receiving on the downlink RF carrier at the same time as it is transmitting on the DM downlink RF carrier f_2 .

NOTE 4: In case of conflicting requirements to receive on the DM uplink RF carrier f_1 and transmit on the TM uplink RF carrier, the TM transmission requirement may override the DM reception requirements defined in this clause.

In case of conflicting requirements to transmit on the DM downlink RF carrier f_2 and receive the TM downlink RF carrier, the TM reception requirement may override the DM transmission requirements defined in this clause.

13.4 Usage of DM channel

13.4.1 Gateway operation

The present document does not support frequency efficient mode for transactions through a gateway.

NOTE 1: This means that a DM-GATE or type 1A DM-REP/GATE can support a single call on the selected DM RF carrier, and a type 1B DM-REP/GATE can support a single call on the two DM RF carriers (f_1 and f_2).

When the gateway is idle (i.e. when it is not supporting a call) and the DM channel is perceived as free, the gateway may transmit a presence signal announcing its presence. The presence signal is used as the timing and frequency reference when a DM-MS makes a call through the gateway.

The gateway is responsible for the timing synchronization of the DM channel.

NOTE 2: If the gateway does not transmit its presence signal on a free channel then a calling DM-MS chooses a channel timing arbitrarily. However, if this timing is unsuitable then the gateway may announce a timing change e.g. when it sends DM-GACK messages. See clause 13.4.7.16.

The gateway is also responsible for the frequency synchronization of the DM channel.

NOTE 3: If the gateway does not transmit its presence signal on a free channel then a calling DM-MS uses its internal frequency reference to generate the transmission frequency for the initial set-up messages. However the gateway uses its own frequency reference (derived from reception of the TM channel) when transmitting. The DM-MSs then align their frequency references to the gateway transmissions and continue to maintain that alignment, as defined in clause 15.

13.4.1.1 DM-GATE operation

For calls using a DM-GATE, communications between the DM-GATE and DM-MSs, and locally between DM-MSs, shall use the same frame and slot numbering. The call is conducted primarily in timeslots 1 and 3 in each frame (except for call set-up messages, which may use all four timeslots). When a DM-MS is transmitting, other DM-MSs on the channel receive the message or traffic directly – without the intervention of the DM-GATE.

The DM-GATE shall synchronize the DM channel (see note 2) so that:

- a) the DM slot timing is closely aligned with the TMO slot timing; and
- b) DM slot 1 lags three timeslots behind the TM downlink slot which the DM-GATE is currently receiving (timeslot number J).

The DM-GATE chooses the DM frame numbering and is not precluded from changing that frame numbering between call transactions. However, it is recommended that the DM-GATE aligns the DM frame numbering with the TMO frame numbering so that DM slot 1 of frame K lags three timeslots behind TM downlink slot J of frame K, and that the DM-GATE changes the DM numbering only if there is a change on the TMO side.

NOTE 1: The internal mechanisms by which the gateway's DM layer 2 receives information from its TMO layer 2 about the current TM channel timings are not specified in the present document. Appropriate mechanisms should be chosen by the gateway designer.

NOTE 2: The alignment defined above minimizes the conflict between requirements to transmit or receive in a timeslot on both the TMO and DMO sides of the gateway. Where a conflict arises, the TMO requirement should normally take precedence. So, for example, the DM-GATE is not required to send call set-up DSBs in DM timeslot 2 (and sometimes cannot send a call set-up DSB in DM timeslot 4).

The DM-GATE is not precluded from using a different alignment on the DMO side. However, if it does so then its physical layer has to have the additional capabilities needed to provide an equivalent service.

13.4.1.2 DM-REP/GATE operation

For calls using a DM-REP/GATE, communications between the DM-REP/GATE and a master DM-MS (when a DM-MS is master of the DM channel) shall use the master link's slot and frame numbering. Communications between the DM-REP/GATE and slave DM-MSs shall use the slave link's slot and frame numbering, which lags three timeslots behind the master link's slot and frame numbering. For each link, the call transaction is conducted primarily in timeslots 1 and 3 in each frame according to that link's slot and frame numbering (except for call set-up messages, which may use all four timeslots).

During call transactions in which a DM-MS is master of the DM channel, the DM-REP/GATE performs a DM repeater function. It receives signalling messages and traffic sent by the master DM-MS (using the master link's slot and frame numbering), and shall re-transmit that information to the called slave DM-MSs (using the slave link's slot and frame numbering). It also may receive signalling messages from slave DM-MSs, in which case it shall re-transmit those messages on the master link to the master DM-MS.

During call transactions in which the DM-REP/GATE is master of the DM channel (i.e. during call transactions originated on the TMO side), during all reservation periods and during registration phases, all communications between the DM-REP/GATE and the DM-MSs shall use the slave link's slot and frame numbering.

For a type 1A DM-REP/GATE, transmissions on the DMO side (by both the DM-REP/GATE and DM-MSs) are sent on the selected DM RF carrier. This applies to both master link and slave link transmissions.

For a type 1B DM-REP/GATE, transmissions from the DM-REP/GATE to DM-MSs are sent on the selected DM downlink RF carrier f_2 whereas transmissions by DM-MSs are sent on the associated (duplex-spaced) DM uplink RF carrier f_1 . This applies to both master link and slave link transmissions.

The DM-REP/GATE shall use the same frequency for both master link and slave link transmissions. Also it shall use the same power level for both master link and slave link transmissions.

The DM-REP/GATE is responsible for the synchronization of the DM channel; see the appropriate clause below.

13.4.1.2.1 Type 1A DM-REP/GATE: DM RF carrier in same sub-band as TM downlink carrier

NOTE 1: This clause may be appropriate also when the DM RF carrier is within e.g. 2,5 MHz of the sub-band containing the TM downlink RF carrier.

The DM-REP/GATE should synchronize the DM channel (see note 2) so that:

- a) the DM slot timing is closely aligned with the TMO slot timing; and
- b) DM slot 1 on the master link is aligned with the TM downlink slot which the DM-REP/GATE is currently receiving (timeslot number J) – and so DM slot 1 on the slave link lags three timeslots behind the TM downlink slot.

The DM-REP/GATE chooses the DM frame numbering and is not precluded from changing that frame numbering between call transactions. However, it is recommended that the DM-REP/GATE aligns the DM frame numbering with the TMO frame numbering so that DM slot 1 of frame K on the master link is aligned with TM downlink slot J of frame K – and so DM slot 1 of frame K on the slave link lags three timeslots behind TM downlink slot J of frame K – and that the DM-REP/GATE changes the DM numbering only if there is a change on the TMO side.

NOTE 2: The alignment defined above minimizes the conflict between requirements to receive the TM downlink RF carrier and transmit on the DM RF carrier.

Where conflict arises between requirements to receive the TM downlink RF carrier and transmit a DSB in a timeslot on the DM RF carrier (timeslot 2 of the slave link or timeslot 1 of the master link), the TMO reception requirement should normally take precedence. So, for example, the DM-REP/GATE sends call set-up DSBs only in slave link timeslots 1, 3 and 4 of the transmission frames; or, when acknowledging a short data message or an unsolicited registration request, the DM-REP/GATE should normally transmit only in master link timeslot 3 of the DSB transmission frames.

If a conflict arises between requirements to receive the TM downlink RF carrier and transmit a DNB on the DM RF carrier then the DM transmission requirement may temporarily take precedence. For example, this may occur if the DM-REP/GATE ever needs to send a fragmented DM-SDS ACK message.

13.4.1.2.2 Type 1A DM-REP/GATE: DM RF carrier in same sub-band as TM uplink carrier

NOTE 1: This clause may be appropriate also when the DM RF carrier is within e.g. 2,5 MHz of the sub-band containing the TM uplink RF carrier.

The DM-REP/GATE may synchronize the DM channel (see note 2) so that:

- a) the DM slot timing is closely aligned with the TMO slot timing; and
- b) DM slot 1 on the master link is one timeslot ahead of the TM downlink slot which the DM-REP/GATE is currently receiving (timeslot number J) – and so DM slot 1 on the slave link lags two timeslots behind the TM downlink slot.

The DM-REP/GATE chooses the DM frame numbering and is not precluded from changing that frame numbering between call transactions. However, it is recommended that the DM-REP/GATE aligns the DM frame numbering with the TMO frame numbering so that DM slot 1 of frame K on the master link is one timeslot ahead of TM downlink slot J of frame K – and so DM slot 1 of frame K on the slave link lags two timeslots behind TM downlink slot J of frame K – and that the DM-REP/GATE changes the DM numbering only if there is a change on the TMO side.

NOTE 2: The alignment defined above minimizes the conflict between requirements to transmit on the TM uplink RF carrier and receive on the DM RF carrier (timeslot 1 of the slave link or timeslot 4 of the master link). Where conflict arises, the TMO transmission requirement should normally take precedence. For example, this may mean that the DM-REP/GATE occasionally cannot monitor for a DM-CONNECT, DM-DISCONNECT, DM-SDS ACK or DM-GCANCEL ACK message in timeslot 1 of the slave link (though it can still monitor in timeslot 3).

The alignment defined above minimizes the conflict between requirements to transmit on the TM uplink RF carrier and receive on the DM RF carrier. However it means that there is a frequent requirement to transmit at the same time on both the TM uplink RF carrier and the DM RF carrier. An alternative possible method could be to use the alignment defined in clause 13.4.1.2.1. However this means that, during call transactions in which a DM-MS is master, the DM-REP/GATE is not able to monitor master timeslot 3 of frames 1 to 17 (where the master DM-MS may send a DM-OCCUPIED message in frames 6 and 12, or may send DM-PRE ACCEPT, DM-TX CEASED or DM-RELEASE in any frame). This degrades the DM channel maintenance procedures. If the DM-REP/GATE uses this method then it shall regenerate DM-OCCUPIED messages on the slave link in timeslot 3 of frames 6 and 12 and also regenerate missing repetitions of DM-TX CEASED, DM-RELEASE and DM-PRE ACCEPT, as defined in clause 13.4.8.3.

13.4.1.2.3 Type 1A DM-REP/GATE (if DM RF carrier not in TMO sub-band) or type 1B DM-REP/GATE with frequency usage method 1

NOTE 1: For a type 1A DM-REP/GATE: if the DM RF carrier is close to either TMO sub-band (e.g. within 2,5 MHz) then clauses 13.4.1.2.1 or 13.4.1.2.2 may be more appropriate.

The DM-REP/GATE shall synchronize the DM channel (see note 2) so that:

- a) the DM slot timing is closely aligned with the TMO slot timing; and
- b) DM slot 1 on the master link lags two timeslots behind the TM downlink slot which the DM-REP/GATE is currently receiving (timeslot number J) – and so DM slot 1 on the slave link lags five timeslots behind the TM downlink slot.

The DM-REP/GATE chooses the DM frame numbering and is not precluded from changing that frame numbering between call transactions. However, it is recommended that the DM-REP/GATE aligns the DM frame numbering with the TMO frame numbering so that DM slot 1 of frame K on the master link lags two timeslots behind TM downlink slot J of frame K – and so DM slot 1 of frame K on the slave link lags five timeslots behind TM downlink slot J of frame K – and that the DM-REP/GATE changes the DM numbering only if there is a change on the TMO side.

NOTE 2: The alignment defined above minimizes the conflict between requirements to transmit on both the TM uplink RF carrier and the DM RF carrier at the same time. Where a conflict arises, the TMO requirement should normally take precedence.

The DM-REP/GATE is not precluded from using a different alignment on the DMO side. However, if it does so then its physical layer needs to have the additional capabilities needed to provide an equivalent service.

13.4.1.2.4 Type 1B DM-REP/GATE with frequency usage method 2

NOTE: This clause may be appropriate also when the DM uplink RF carrier f_1 is within e.g. 2,5 MHz of the sub-band containing the TM uplink RF carrier or the DM downlink RF carrier f_2 is within e.g. 2,5 MHz of the sub-band containing the TM downlink RF carrier.

The DM-REP/GATE should synchronize the DM channel so that:

- a) the DM slot timing is closely aligned with the TMO slot timing; and
- b) DM slot 1 on the master link is aligned with the TM downlink slot which the DM-REP/GATE is currently receiving (timeslot number J) – and so DM slot 1 on the slave link lags three timeslots behind the TM downlink slot.

The DM-REP/GATE chooses the DM frame numbering and is not precluded from changing that frame numbering between call transactions. However, it is recommended that the DM-REP/GATE aligns the DM frame numbering with the TMO frame numbering so that DM slot 1 of frame K on the master link is aligned with TM downlink slot J of frame K – and so DM slot 1 of frame K on the slave link lags three timeslots behind TM downlink slot J of frame K – and that the DM-REP/GATE changes the DM numbering only if there is a change on the TMO side.

The following procedures apply in case of conflict between transmission and reception:

- 1) The alignment defined above minimizes the conflict between requirements to receive the TM downlink RF carrier and transmit on the DM downlink RF carrier f_2 .

Where conflict arises between requirements to receive the TM downlink RF carrier and transmit a DSB in a timeslot on the DM downlink RF carrier f_2 (timeslot 2 of the slave link or timeslot 1 of the master link), the TMO reception requirement should normally take precedence. So, for example, the DM-REP/GATE sends call set-up DSBs only in slave link timeslots 1, 3 and 4 of the transmission frames; or, when acknowledging a short data message or an unsolicited registration request, the DM-REP/GATE should normally transmit only in master link timeslot 3 of the DSB transmission frames.

If a conflict arises between requirements to receive the TM downlink RF carrier and transmit a DNB on the DM downlink RF carrier f_2 then the DM transmission requirement may temporarily take precedence. For example, this may occur if the DM-REP/GATE ever needs to send a fragmented DM-SDS ACK message.

- 2) The alignment defined above minimizes the overall conflict between requirements to transmit on one side and receive on the other side.

However conflict remains between requirements to transmit on the TM uplink RF carrier and receive on the DM uplink RF carrier f_1 (timeslot 3 of the master link or timeslot 4 of the slave link). Where conflict arises, the TMO transmission requirement should normally take precedence.

This means that, during call transactions in which a DM-MS is master, the DM-REP/GATE is not able to monitor master link timeslot 3 of frames 1 to 17 (where the master DM-MS may send a DM-OCCUPIED message in frames 6 and 12, or may send DM-PRE ACCEPT, DM-TX CEASED or DM-RELEASE in any frame). Therefore the DM-REP/GATE shall:

- regenerate DM-OCCUPIED messages on the slave link in timeslot 3 of frames 6 and 12; and
- regenerate DM-TX CEASED, DM-RELEASE and DM-PRE ACCEPT messages in slave link timeslot 3, using the elements from messages received from the master DM-MS in timeslot 1

using the method described in clause 13.4.8.3.

13.4.2 Gateway DM-MAC states

The gateway shall monitor activity on the appropriate DM RF carrier in order to determine the current state of the channel and to receive any signalling messages addressed to itself.

13.4.2.1 Gateway DM-MAC state definitions

The following states are defined for the gateway DM-MAC, based on its own activity and the current state of the channel. These shall be used to determine which procedure the gateway follows at any point in time.

0) Gateway idle – state of channel unknown

The gateway is currently operating in idle mode and does not know the state of the channel. This state applies at the following times:

- following initial power-up in direct mode or when the gateway has just been switched into direct mode operation or when the user has just selected a different DM channel; or
- when required or allowed by the protocol e.g. following expiry of inactivity timer DT267.

1) Gateway idle – channel free

The gateway is currently operating in idle mode on a channel which is perceived as free i.e. no activity is detected on the channel (except possible detection of other DM-REP or gateway presence signals indicating that the channel is free).

2) Gateway idle – channel occupied

The gateway is currently operating in idle mode on a channel which is perceived as being occupied i.e. signalling or traffic information not addressed to the gateway is detected on the channel, or other activity is detected on the channel.

3) Gateway idle – channel reserved

The gateway is currently operating in idle mode on a channel which is perceived as being reserved i.e. channel reservation signalling is detected on the channel.

4) Gateway idle – channel in registration phase

The gateway is currently operating in idle mode on a channel which is perceived as being in a registration phase with another gateway as master.

5) Gateway active as master in channel occupation

The gateway is in active mode as master of the DM channel, transmitting traffic and/or signalling in a call transaction that originated on the TMO side. This may be a circuit mode traffic transmission or a short data transmission (DM-SDS UDATA or DM-SDS DATA), or may be a registration cancellation.

6) Gateway active as slave in channel occupation

The gateway is in active mode in a call involving that gateway, receiving traffic and/or signalling for a call transaction originated by a DM-MS. This may be a circuit mode traffic transmission or a short data transmission, or may be an unsolicited registration.

If the gateway is a DM-REP/GATE then it re-transmits the master DM-MS's traffic and/or signalling on the slave link. It also re-transmits other DM-MSs' pre-emption requests on the master link.

7) Gateway active as master in channel reservation

The gateway is in active mode as master of the DM channel, periodically transmitting channel reservation signalling during a reservation period in a call involving that gateway (either during call set-up or after a call transaction).

8) Gateway active as master in registration phase

The gateway is in active mode as master of the DM channel, soliciting registration requests.

13.4.2.2 Gateway channel surveillance procedures

A gateway shall conduct channel surveillance procedures on the appropriate DM RF carrier in order to determine its current state.

13.4.2.2.1 Channel surveillance when idle on a channel in unknown or free state (i.e. in state 0 or 1)

When in idle mode on a channel whose state is unknown or on a free channel, the gateway shall perform the following channel surveillance:

- A DM-GATE shall continuously monitor the selected DM RF carrier in order to detect any DSBs present and, when signal strength and channel conditions permit, decode any layer 2 information available, except that it need not perform this monitoring when it is transmitting its gateway presence signal or linearizing or when it is transmitting or receiving on the TMO side.
- A type 1A DM-REP/GATE shall continuously monitor the selected DM RF carrier in order to detect any DSBs present and, when signal strength and channel conditions permit, decode any layer 2 information available, except that it need not perform this monitoring when it is transmitting its gateway presence signal or linearizing or when it is transmitting on the TMO side.
- A type 1B DM-REP/GATE shall continuously monitor the DM uplink RF carrier f_1 in order to detect any DSBs present and, when signal strength and channel conditions permit, decode any layer 2 information available, except that it need not perform this monitoring when it is transmitting its gateway presence signal or linearizing (or when it is monitoring the DM downlink RF carrier f_2 – see note 1).

NOTE 1: As defined above, an idle type 1B DM-REP/GATE is required to monitor the DM uplink RF carrier f_1 . This is so that it can receive DM-MS call set-up signalling messages containing its own gateway address. Also, unless it is known by prior arrangement that another DM-REP/GATE (or DM-REP) will not be using the same DM RF carriers in the same area, it is recommended that the DM-REP/GATE periodically monitors the DM downlink RF carrier f_2 e.g. to check for occupation by another type 1B DM-REP/GATE. For example, the DM-REP/GATE might perform similar surveillance of RF carrier f_2 to that of a DM-MS performing fast call set-up surveillance (e.g. monitoring RF carrier f_2 for two timeslot durations in every two frame durations when the carrier is perceived as being free, or monitoring timeslot 3 of slave link frames 6, 12 and 18 when the carrier is perceived as busy).

This monitoring may be useful also if direct MS-MS operation is used on RF carrier f_2 . Periodic monitoring of RF carrier f_2 would enable the DM-REP/GATE to detect a direct MS-MS call and thereby regard the channel as busy.

Continuous monitoring of the DM RF carrier means that the gateway shall sample the DM RF carrier at a sufficient rate so that the presence of a DSB may be determined.

In the case where a DSB is detected the gateway shall, dependent upon the content, enter the appropriate mode of operation and update the DM-MAC state model (see clause 13.4.3.3); see also note 2.

NOTE 2: A gateway is permitted to implement a signal strength threshold where the gateway need not regard the channel as busy as a result of receiving DSBs below that threshold. For example, the signal strength threshold may be set to the receiver sensitivity level.

In the case where the channel state is unknown, if no DSBs other than free-channel presence signals are detected for 19 consecutive frame durations, then the gateway may regard the channel as free.

NOTE 3: In the absence of DSBs the gateway may choose to conduct additional channel surveillance procedures, e.g. signal strength measurements, in order to determine whether the DM RF carrier is free and available for use.

NOTE 4: For the first 19 frame durations after the gateway has been switched into direct mode operation or following initial power-up in direct mode, channel surveillance on the DM RF carrier may take precedence over TMO requirements to transmit and/or receive on the TM channel.

13.4.2.2.2 Channel surveillance when idle on a busy channel (i.e. in state 2, 3 or 4)

When in idle mode on a busy channel, the gateway channel surveillance shall be as follows:

- The gateway shall monitor slot 3 at least every two frames if this does not conflict with TMO requirements. Monitoring of timeslot 3 of frame 3 does not contribute to fulfilling this requirement. The monitoring shall include timeslot 3 of frames 6, 12 and 18.
- Otherwise the gateway shall monitor in timeslot 1 at least every two frames. During circuit mode occupation, the gateway shall look for a DNB when monitoring in timeslot 1 of frames 1 to 17. If the gateway detects normal training sequence 2, it shall attempt to decode the STCH and may use the parts of C-plane signalling messages that are visible at layer 2. When monitoring in timeslot 1 at other times, the gateway shall attempt to decode a DSB.

The gateway shall update the DM-MAC state model if it detects DSB(s) which indicate that the channel state has changed, see clause 13.4.3.3; see also note 3.

NOTE 1: If an idle gateway detects DSB(s) which indicate that the DM channel is busy (i.e. occupied or reserved or in a registration phase) then it should assume that the DM channel is still occupied or reserved or in a registration phase until it receives DSB(s) which indicate that the channel state has changed or until the appropriate timer expires (e.g. DT267, reservation time remaining, SDS time remaining, registration phase time remaining or registration transaction time remaining). See clause 13.4.3.3.

NOTE 2: A DM-GATE or type 1A DM-REP/GATE performs the specified monitoring on the selected DM RF carrier.

A type 1B DM-REP/GATE should perform the specified monitoring on the appropriate DM RF carrier. For example, if the DM-REP/GATE detected the DM downlink RF carrier f_2 as becoming busy then it should perform the monitoring on f_2 ; if it detected the DM uplink RF carrier f_1 as becoming busy then it may perform the monitoring on either f_1 or f_2 as appropriate.

NOTE 3: A gateway is permitted to implement a signal strength threshold where the gateway need not regard the channel as busy as a result of receiving DSBs below that threshold. For example, the signal strength threshold may be set to the receiver sensitivity level.

13.4.2.2.3 Channel surveillance when idle at DM-MS call set-up

If the gateway is in idle mode and receives a DM-GSETUP message containing its own 10-bit gateway address then:

- if the channel surveillance procedures described in clauses 13.4.2.2.1 and 13.4.2.2.2 indicate that the channel was free then the gateway layer 2 shall deliver the message to layer 3; or
- if the channel surveillance procedures indicate that the channel was in the unknown state then the gateway layer 2 may deliver the message to layer 3; or
- if the channel surveillance procedures indicate that the channel was busy then the gateway layer 2 shall ignore the DM-GSETUP message.

If the gateway is in idle mode and receives an unsolicited registration request (DM-GREGISTER REQUEST message) containing its own 10-bit gateway address then:

- if the channel surveillance procedures indicate that the channel was free then a DM-REP/GATE shall re-transmit the message on the slave link; also the layer 2 in either a DM-GATE or DM-REP/GATE shall deliver the message to layer 3; or
- if the channel surveillance procedures indicate that the channel was in the unknown state then a DM-REP/GATE may re-transmit the message on the slave link; also the layer 2 in either a DM-GATE or DM-REP/GATE may deliver the message to layer 3; or
- if the channel surveillance procedures indicate that the channel was busy then the gateway layer 2 shall ignore the DM-GREGISTER REQUEST message.

If the gateway is in idle mode and receives a short data message DSB (DM-SDS UDATA or DM-SDS DATA message) containing its own 10-bit gateway address then:

- if the channel surveillance procedures indicate that the channel was free or in the unknown state then a DM-REP/GATE may re-transmit the message on the slave link; also the layer 2 in either a DM-GATE or DM-REP/GATE may continue to process the message and deliver it to layer 3; or
- if the channel surveillance procedures indicate that the channel was busy then a DM-REP/GATE shall not re-transmit the message on the slave link. The layer 2 in either a DM-GATE or DM-REP/GATE is not precluded from continuing to process the message to deliver it to layer 3 (for onward transmission to the SwMI); however, for a DM-SDS DATA message, layer 2 shall indicate the received message type to layer 3 as being DM-SDS UDATA so that layer 3 will not respond.

NOTE 1: In the above, the gateway conducts the channel surveillance procedures while it is in idle mode i.e. prior to receipt of the DM-GSETUP or DM-GREGISTER REQUEST message, or the DM-SDS UDATA or DM-SDS DATA DSB.

NOTE 2: In the above, a DM-GATE or type 1A DM-REP/GATE receives the DM-GSETUP, DM-GREGISTER REQUEST, DM-SDS UDATA or DM-SDS DATA message on the selected DM RF carrier.

A type 1B DM-REP/GATE receives the DM-GSETUP, DM-GREGISTER REQUEST, DM-SDS UDATA or DM-SDS DATA message on the DM uplink RF carrier f_1 . The type 1B DM-REP/GATE regards the channel as being free only if its channel surveillance procedures indicate that DM RF carrier f_1 was free and (if performing channel surveillance on DM RF carrier f_2) that DM RF carrier f_2 is also free.

NOTE 3: The gateway is permitted to implement a signal strength threshold where it need not regard the channel as busy as a result of receiving DSBs below that threshold. Also, under some circumstances, the gateway is not precluded from accepting a call set-up even if it perceived the channel as being busy e.g. if the new call is an emergency call. If using this option, the gateway may choose to monitor the channel more frequently than specified in clause 13.4.2.2.2 and may look for DSBs sent using different slot timings.

13.4.2.2.4 Channel surveillance before call set-up by gateway (circuit mode call or short data)

The gateway may generally begin call set-up procedures on the DM channel, for a circuit mode call or short data message originated on the TMO side, if the channel surveillance procedures indicate that the channel is free.

NOTE 1: The predefined broadcast or "open" group address ("all ones" address) defines a group to which all MSs belong. If the gateway's call set-up is to the predefined broadcast group address then, unless it is known by prior arrangement that another gateway will not be using the same DM RF carrier(s) in the same area, the gateway should observe the channel for a random period before transmitting. This is in order to avoid collision if another gateway may be intending to set up the same TMO call on the same DM RF carrier in the same area.

Apart from the predefined broadcast group address, the present document does not support operation where multiple gateways using the same DM RF carrier(s) in the same area are supporting the same group address.

However, if the gateway observes a channel change from busy to free (e.g. at the end of the frame countdown for a transmitted or received DM-RELEASE message or if it detects the end of circuit mode reservation, SDS occupation or a registration phase) and if, within the following time DT265, it wishes to set up a call then it shall choose an integer R randomly from the range DN264 to DN265 (using a uniform distribution) and plan to start sending the call set-up signalling after R frame durations. During the intervening time, the gateway shall continue to monitor the DM RF carrier(s) and if it detects a DSB that causes a change of DM-MAC state then it shall either report to layer 3 that the call set-up message cannot be sent or use the option described in note 5.

The following exception applies in the case of a new call pre-emption acceptance. If the gateway observes a channel change from busy to free as the result of a new call pre-emption acceptance (i.e. at the end of the frame countdown for a transmitted or received DM-PRE ACCEPT message containing "new call pre-emption" set to 1 and addressed to another DM-MS or at the end of the frame countdown for a received free channel presence signal with "registration phase terminated flag" set to 1) and if, within the following time DT276, the gateway wishes to set up a call then the gateway shall choose an integer R randomly from the range DN264 + 8 to DN265 + 8 (using a uniform distribution) and plan to start sending the call set-up signalling after R frame durations. However, during the intervening time, the gateway shall continuously monitor the DM RF carrier(s). If, during this time, it detects a DSB that causes a change of DM-MAC state then it shall either report to layer 3 that the call set-up message cannot be sent or use the option described in note 5.

NOTE 2: In the case of new call pre-emption acceptance during circuit mode occupation, the master DM-MS sends both DM-PRE ACCEPT and DM-RELEASE (with the two messages sent in the two halves of slot 1 and DM-PRE ACCEPT sent in slot 3).

If a gateway transmits a DM-PRE ACCEPT for a new call, or receives both DM-PRE ACCEPT and DM-RELEASE, or receives only a DM-PRE ACCEPT for a new call, then it uses the above procedure if it wishes to make a call within the following time DT276.

NOTE 3: If time DT265 is longer than time DT276 then the normal procedure for choosing R from the range DN264 to DN265 applies between time DT276 and DT265.

An implementer may avoid this possibility, for example, by setting DT276 to the maximum of DT265 and 9 frames. This may enable a simpler implementation.

NOTE 4: In the procedures in the above two paragraphs, if the gateway wishes to use a specific DM timing reference for its call (see clause 13.4.1), it may extend the continuous monitoring period by up to one frame duration (i.e. monitoring for up to one frame duration in addition to the R frame durations) in order to transmit using the required timing. For example, this may apply if the gateway wishes to use a timing reference based on the timing of a previous call or on the dual watch synchronization.

For a retransmission of DM-SETUP PRES by layer 3 or a non-immediate retransmission of DM-SDS DATA, the gateway shall choose an integer R randomly from the range DN266 to DN267 (using a uniform distribution) and plan to start sending the message after R frame durations. However, during the intervening time, the gateway shall continue to monitor the DM RF carrier(s). If, during this time, it detects a DSB that causes a change of DM-MAC state then it shall either report to layer 3 that the message cannot be sent or use the option described in note 5.

If the above procedures would result in the gateway transmitting call set-up signalling during another gateway's or DM-REP's transmission of a multiple-frame free-channel presence signal then the gateway shall wait until the end of the repetitions of the presence signal. It may then either transmit its call set-up signalling immediately or choose a new value of integer R randomly from the specified range and plan to start sending its message after R frame durations. This applies also in clauses 13.4.2.2.5 and 13.4.2.2.6.

NOTE 5: If the channel is busy, or becomes busy, with a short transaction (e.g. an unsolicited registration or a registration cancellation by another gateway), the gateway may choose to wait for the end of that transaction and then choose a new value of R instead of reporting to layer 3 that the call set-up message cannot be sent. This may apply also in clause 13.4.2.2.6.

13.4.2.2.5 Channel surveillance before registration phase

The gateway may begin a registration phase if the channel surveillance procedures indicate that the channel is perceived as being free.

If the channel is not perceived as being free then the gateway shall continue to monitor the DM channel and wait for the channel to become free. When it observes the channel become free then it shall choose an integer R randomly from the range DN274 to DN275 (using a uniform distribution) and plan to initiate the registration phase after R frame durations. It shall continue to monitor the DM RF carrier(s) during the intervening time and if it detects traffic or signalling activity it shall again wait for the channel to become free and re-choose a new value for R.

It shall continue the process of channel surveillance until it either successfully initiates the registration phase or it receives a DMC-CONFIGURE request primitive from layer 3 cancelling the registration phase.

13.4.2.2.6 Channel surveillance before registration cancellation

The gateway shall check whether the channel is free before transmitting the DM-GREGISTER CANCEL message.

- If the channel is free then the gateway shall transmit the message using the procedures defined in clause 13.5.6.
- If the channel is not perceived as free, then the gateway shall continue to monitor the channel.
 - If the channel does not become free within a time $DT275$ then the gateway shall report to layer 3, using the GMA-REPORT indication, that the message cannot be sent.
 - If the gateway observes the channel become free then it shall choose an integer R randomly from the range DN276 to DN277 (using a uniform distribution) and plan to start sending the message after R frame durations. It shall continue to monitor the DM RF carrier(s) during the intervening time and if it detects traffic or signalling activity then it shall report to layer 3, using the GMA-REPORT indication, that the message cannot be sent.

For a retransmission of the DM-GREGISTER CANCEL message by layer 3, the gateway shall choose an integer R randomly from the range DN278 to DN279 (using a uniform distribution) and plan to start sending the message after R frame durations. However, during the intervening time, the gateway shall continue to monitor the DM RF carrier(s). If, during this time, it detects traffic or signalling activity then it shall report to layer 3 that the message cannot be sent.

13.4.2.3 Master gateway channel maintenance during a call

When master of the DM channel during channel reservation, if the DM-MAC receives signalling messages on the DM channel indicating that the channel has become occupied by other users then it may give up its call. If so the DM-MAC shall inform the higher layers (using the GMC-REPORT indication) and the gateway should then send a DM-RELEASE message, which the DM-MAC transmits before becoming idle. If the gateway does not send a DM-RELEASE message then it shall begin idle mode operating procedures.

NOTE 1: The gateway may choose whether to give up its own call if it receives signalling messages from other users. Criteria for the choice could be based on parameters such as the priority of the gateway's own call, the priority of the other signalling messages and/or the received signal strength of the other signalling.

NOTE 2: The gateway may also perform the above procedure when it is master during circuit mode occupation.

13.4.2.4 Slave gateway channel maintenance during a call

During a circuit mode call transaction in which a DM-MS is master of the channel, the gateway shall, based upon the signalling present on the DM channel, update the DM-MAC state model accordingly.

If a time $DT266$ elapses without receipt of a DM-OCCUPIED message for the call transaction then the gateway DM-MAC shall assume that the call has been lost (informing layer 3 using the GMC-REPORT indication) and shall enter idle mode; the gateway shall then either assume the channel is free and send the gateway presence signal, indicating that the channel is free, which causes receiving DM-MSs to release the call, or shall assume the state of the channel is unknown.

NOTE: If a slave DM-MAC receives signalling messages on the DM channel indicating that the channel has become occupied by other users then it may inform the higher layers (using the DMC-REPORT indication) and begin idle mode operating procedures.

13.4.3 Criteria for changing gateway state

13.4.3.1 Criteria for changing DM-MAC state for master gateway

When the gateway is master on a DM channel, the DM-MAC shall, based upon the signalling received or sent on the DM channel, update its state model accordingly. It shall change the current state condition if one of the following occurs:

- a) The gateway transmits a channel state change command on the DM channel e.g. a message indicating call set-up for a call transaction that originated in the TMO system or indicating end of channel occupation, start or end of channel reservation, or call release.
- b) The gateway receives and accepts a request for channel changeover or pre-emption within the ongoing call.
The DM-MAC shall then enter state "Gateway active as master in channel reservation" with a reservation time remaining of 001111_2 (5 multiframe) measured relative to the final repetition of the acceptance message.
- c) The gateway receives and accepts a request for new call pre-emption.
The gateway regards the pre-emption acceptance as being the end of the current call, so the DM-MAC shall enter state "Gateway idle – channel free".
- d) The gateway completes a short data transaction or a registration cancellation transaction.
- e) The gateway signals the start or end of a registration phase.
- f) The gateway receives a valid DM-GSETUP message containing its own 10-bit gateway address and it decides to obey the incoming call set-up.
- g) The gateway detects that the channel is occupied by other DM-MS and decides to relinquish the channel itself, see clause 13.4.2.3.
- h) The DM-MAC receives a GMC-CONFIGURE request primitive from layer 3 indicating a state change.

At the end of a call, the DM-MAC shall enter state "Gateway idle – channel free".

13.4.3.2 Criteria for changing DM-MAC state for slave gateway

When the gateway is slave on a DM channel, the DM-MAC shall, based upon the signalling received on the DM channel, update its state model accordingly. It shall change the current state if one of the following occurs:

- a) The gateway receives a channel state change command from the current or new master DM-MS e.g. DM-SETUP message or a DM-SDS UDATA or DM-SDS DATA DSB or an unsolicited registration message or a message indicating end of channel occupation or call release.
- b) The gateway receives a call set-up message addressed to itself but not related to the ongoing call, and it decides to obey the incoming call set-up.
- c) The gateway receives an acceptance of its own pre-emption within the ongoing call, sent by the current master.
The gateway then sends call set-up signalling and the DM-MAC shall enter state "Gateway active as master in channel reservation".
- d) The gateway receives an acceptance of another DM-MS pre-emption within the ongoing call, sent by the current master.
The DM-MAC shall enter state "Gateway active as master in channel reservation".
- e) The gateway receives an acceptance of its own pre-emption for a new call, sent by the current master.
The gateway then sends call set-up signalling and the DM-MAC shall enter state "Gateway active as master in channel reservation".

- f) The gateway receives an acceptance of pre-emption for a new call for another DM-MS, sent by the current master.

The gateway regards the pre-emption acceptance as being the end of the current call so the DM-MAC shall enter state "Gateway idle – channel free".

- g) A time DT266 has elapsed without receipt of a DM-OCCUPIED from the current master, see clause 13.4.2.4.
- h) The gateway detects that the channel is occupied by other DM-MS and decides to relinquish the channel itself, see clause 13.4.2.4.

The DM-MAC shall enter state "Gateway idle – channel occupied".

- j) The gateway is in short data occupation, and a time corresponding to the "SDS time remaining" element from the last received DM-SDS DATA, DM-SDS UDATA or DM-SDS OCCUPIED DSB has elapsed since receipt of that DSB.

The DM-MAC shall enter state "Gateway idle – channel free".

- k) The DM-MAC receives a GMC-CONFIGURE request primitive from layer 3 indicating a state change.

If the GMC-CONFIGURE request indicates "idle operation" and relates to expiry of a DM layer 3 timer (i.e. timer DT363), the DM-MAC shall either immediately initiate transmission of a free channel presence signal and enter state "gateway idle – channel free", or enter state "gateway idle – state of channel unknown".

13.4.3.3 Criteria for changing DM-MAC state for idle gateway

When the gateway is idle on a DM channel, the DM-MAC shall, based upon the signalling received on the DM channel, update its state model accordingly. It shall update the current state if one of the following occurs:

- a) The gateway receives a DSB but the message type cannot be decrypted or the SYNC PDU type or message type is not understood.

The DM-MAC shall enter (or remain in) state "Gateway idle – channel occupied".

- b) The gateway receives a valid DM-GSETUP message containing its own 10-bit gateway address and it decides to obey the incoming call set-up.

The DM-MAC shall enter state "Gateway active as master in channel reservation".

- c) The gateway receives a call set-up message for a short data message containing its own 10-bit gateway address.

The DM-MAC shall enter state "Gateway active as slave in channel occupied".

- d) The gateway receives a call set-up or DM-OCCUPIED message not addressed to itself, or a DM-CONNECT ACK or DM-SDS OCCUPIED message.

The DM-MAC shall enter (or remain in) state "Gateway idle – channel occupied".

- e) The gateway receives a message from a call it is not involved in indicating reservation e.g. DM-TX CEASED or DM-RESERVED with "reservation time remaining" > 0.

The DM-MAC shall enter (or remain in) state "Gateway idle – channel reserved".

- f) The gateway receives a message indicating end of a call it is not involved in e.g. DM-RESERVED with "reservation time remaining" = 0 sent in a frame 6, 12 or 18, or DM-RELEASE.

At the end of a normal mode call, the DM-MAC shall enter (or remain in) state "Gateway idle – channel free". At the end of a frequency efficient mode call, the DM-MAC shall enter state "Gateway idle – state of channel unknown" unless it able to follow the states of both channel A and channel B independently.

- g) The gateway receives an acceptance of changeover or pre-emption within an ongoing call.

The DM-MAC shall enter (or remain in) state "Gateway idle – channel reserved".

- h) The gateway receives an acceptance of its own pre-emption for a new call sent by the current master.
The gateway then sends call set-up signalling and the DM-MAC shall enter state "Gateway active as master in channel reservation".
- j) The gateway receives an acceptance of pre-emption for a new call for another DM-MS, sent by the current master.
The gateway regards the pre-emption acceptance as being the end of the current call so the DM-MAC shall enter (or remain in) state "Gateway idle – channel free".

NOTE 1: A specific monitoring and randomization procedure applies if the gateway then wishes to make a call within the next time DT276; see clause 13.4.2.2.4.

- k) The gateway receives a DM-TIMING ACK message.
The DM-MAC shall enter (or remain in) state "Gateway idle – channel reserved" – unless the DM-MAC was in state "Gateway idle – channel occupied" and the DM-TIMING ACK message did not announce a timing change, in which case the DM-MAC shall remain in the current state.
- l) The gateway is idle on a free channel, or the state of the channel is unknown, and the gateway receives a response message sent by a slave or a random access message or a DM-REJECT message.
The DM-MAC shall either enter (or remain in) state "Gateway idle – state of channel unknown", or enter state "Gateway idle – channel occupied" or state "Gateway idle – channel reserved" as appropriate.
- m) The gateway is idle in channel occupation or reservation, and a time DT267 has elapsed without receipt of a DSB from the current or new master (or a DSB where the message type cannot be decrypted or the SYNC PDU type or message type is not understood).
The DM-MAC shall either enter state "Gateway idle – state of channel unknown" or enter state "Gateway idle – channel free".
- n) The gateway is idle in channel reservation, and a time corresponding to the "reservation time remaining", either from the last received DM-TX CEASED or DM-RESERVED message or DM-GACK message with "reservation announced" element set to 1, or assumed on receipt of an acceptance of changeover or pre-emption within an ongoing call, has elapsed since receipt of that message.
The DM-MAC shall enter state "Gateway idle – channel free".
- o) The gateway is idle in short data occupation, and a time corresponding to the "SDS time remaining" element from the last received DM-SDS DATA, DM-SDS UDATA or DM-SDS OCCUPIED DSB has elapsed since receipt of that DSB.
The DM-MAC shall enter state "Gateway idle – channel free".
- p) The gateway receives a presence signal from a DM-REP or another gateway indicating that the channel is not free.
- q) The gateway receives a presence signal from a DM-REP or another gateway indicating that the channel is free then:
 - if the channel is currently perceived as being busy in a call or registration phase involving the transmitting gateway or DM-REP, then the receiving gateway shall change the perceived DM channel state to free;
 - if the channel is currently perceived as being busy in a call or registration phase not involving the transmitting gateway or DM-REP, then the receiving gateway shall not change the perceived DM channel state.
- r) The gateway is idle in another gateway's registration phase, and a time corresponding to the "registration phase time remaining" element from the last received REGISTRATION-phase gateway presence signal has elapsed since receipt of that message.
The DM-MAC shall enter state "Gateway idle – channel free".

- s) The gateway is idle in another gateway's registration phase, and a time corresponding to the "registration transaction time remaining" element has elapsed since receipt of the last appropriate registration DSB.

The DM-MAC shall enter state "Gateway idle – channel free".

- t) The gateway is idle in another gateway's registration phase and it receives a DM-PRE ACCEPT message from that other gateway.

The DM-MAC shall enter state "Gateway idle – channel occupied".

- u) The gateway receives a GMC-CONFIGURE request primitive from layer 3 indicating a state change.

NOTE 2: A gateway is permitted to implement a signal strength threshold where the gateway need not regard the channel as busy as a result of receiving DSBs below that threshold. For example, the signal strength threshold may be set to the receiver sensitivity level.

13.4.4 Gateway channel monitoring procedures

A gateway in idle mode shall monitor the appropriate DM RF carrier(s) in order to keep an up-to-date record of the perceived state of the channel and to receive any call set-up messages containing its own 10-bit gateway address; refer to clause 13.4.2.2.

The following clauses define the minimum monitoring requirements when the gateway is in active mode – in a call involving that gateway or in a registration phase.

NOTE 1: The following channel monitoring procedures apply only when practicable. In case of conflict of requirements, TMO requirements and DM transmission requirements may take precedence over DM monitoring requirements (in which case the gateway monitors as specified, but only in those DM slots for which there is no conflict).

NOTE 2: For a DM-GATE or type 1A DM-REP/GATE, the following channel monitoring procedures refer to the selected DM RF carrier. For a type 1B DM-REP/GATE, they refer to the DM uplink RF carrier f_1 .

13.4.4.1 DM channel during reception of fragmented DM-GSETUP message

After receiving DMAC-SYNC PDU(s) indicating a fragmented DM-GSETUP message containing its own 10-bit gateway address, the gateway shall monitor timeslot 1 of the appropriate frame for a DNB containing the DMAC-END PDU; see clause 13.5.4.2.

NOTE 1: For a DM-REP/GATE, this requirement refers to timeslot 1 on the slave link.

NOTE 2: Monitoring for a DNB containing the DMAC-END PDU may take precedence over TMO requirements to transmit or receive on the TM channel. This may apply if the DM-MS used an arbitrary channel timing when sending the DM-GSETUP message.

13.4.4.2 DM channel during call set-up with presence check

For a circuit mode call set-up with presence check, after transmission of the DM-SETUP PRES messages, the gateway shall monitor for a DSB in at least timeslots 1 and 3 of the frames allocated for acknowledgements transmitted from the called DM-MS.

NOTE 1: For a DM-REP/GATE, this requirement refers to timeslots on the slave link.

NOTE 2: Improved operation may be achieved if the gateway also monitors timeslots 2 and 4 when practicable.

13.4.4.3 DM channel in reservation during circuit mode call set-up

While the DM channel is in reservation during a circuit mode call set-up through the gateway, and if the gateway has invited pre-emption requests, the gateway shall monitor timeslot 3 for a DSB containing pre-emption request signalling. The gateway shall conduct this monitoring in all frames except frame 3 and those frames in which it is transmitting and those frames which are precluded as indicated by the "requests bitmap".

NOTE 1: For a DM-REP/GATE, this requirement refers to timeslots on the slave link.

NOTE 2: A reservation period during circuit mode call set-up may occur for either a call originated by a DM-MS or a call with presence check originated in the TMO system.

13.4.4.4 DM channel following circuit mode connection by gateway

After transmitting DM-GCONNECT messages, the gateway shall monitor for a DSB in at least timeslots 1 and 3 of the frames allocated for call set-up (or release) messages transmitted from the calling DM-MS.

NOTE 1: For a DM-REP/GATE, this requirement refers to timeslots on the master link.

NOTE 2: Improved operation may be achieved if the gateway also monitors timeslots 2 and 4 when practicable.

NOTE 3: In case of failure to receive call set-up messages from the calling DM-MS, layer 3 issues a GMC-CONFIGURE request primitive indicating a state change to idle.

13.4.4.5 Gateway as master in circuit mode occupation

When master during circuit mode occupation, the gateway shall monitor timeslot 3 of frames 2, 5, 8, 11, 14 and 17 for a DSB containing a pre-emption request (DM-PREEMPT or DM-GPREEMPT).

NOTE 1: For a DM-REP/GATE, these requirements refer to timeslots on the slave link.

NOTE 2: The master gateway is not required to monitor timeslot 3 during the transmission of the DM-TX CEASED message at the end of circuit mode occupation.

13.4.4.6 Gateway as slave in circuit mode occupation

When a slave during circuit mode occupation, the gateway shall monitor as follows for bursts transmitted by the master DM-MS:

- a) It shall monitor timeslot 1 of frames 1 to 17 for DNBs containing TCH or STCH.
- b) It shall monitor timeslot 1 of frame 18 for a DSB transmitted by the master DM-MS. It shall also monitor for DSBs transmitted by the master DM-MS in timeslot 3 of all frames except those in which it is transmitting or linearizing. For example, the master DM-MS may send a DM-OCCUPIED message in frames 6, 12 and 18; or it may send a DM-PRE ACCEPT, DM-TX CEASED or DM-RELEASE message in any frame.

NOTE: For a DM-REP/GATE, requirements a) and b) refer to timeslots on the master link.

A DM-REP/GATE shall also monitor timeslot 3 of frames 2, 5, 8, 11, 14 and 17 of the slave link for DSBs carrying pre-emption requests (DM-PREEMPT). Following the re-transmission on the master link of a pre-emption request, the DM-REP/GATE shall continue to monitor timeslots 1 and 3 in the following master link frames, as defined in a) and b), to determine the result of the request.

13.4.4.7 DM channel in reservation during a circuit mode call

While the DM channel is in reservation following the end of a circuit mode call transaction, the gateway shall monitor timeslot 3 for a DSB containing transmit request or pre-emption request signalling. The gateway shall conduct this monitoring in all frames except frame 3 and those frames in which it is transmitting and those frames which are precluded as indicated by the "requests bitmap".

NOTE: For a DM-REP/GATE, this requirement refers to timeslots on the slave link.

13.4.4.8 Gateway as master in SDS occupation

During SDS transmissions the gateway shall monitor timeslot 3 of frames 2, 5, 8, 11, 14 and 17 for a DSB carrying pre-emption request signalling.

For SDS transmissions that require an acknowledgement, the gateway shall monitor at least timeslots 1 and 3 in those frames assigned for acknowledgement messages.

NOTE 1: For a DM-REP/GATE, these requirements refer to timeslots on the slave link.

NOTE 2: Improved operation may be achieved if the gateway also monitors timeslots 2 and 4 when practicable.

13.4.4.9 Gateway as slave in SDS occupation

When a slave during a short data transaction (i.e. while the "SDS time remaining" element indicates a positive value), the gateway shall monitor as follows for bursts transmitted by the master DM-MS:

- a) After receiving DMAC-SYNC PDU(s) indicating a fragmented DM-SDS UDATA or DM-SDS DATA message, the gateway shall monitor timeslot 1 of frames 1 to 17 for DNBs containing SCH/F until it receives the DMAC-END PDU or a DMAC-DATA PDU (e.g. a Null PDU) or fails to decode one of the SCH/F slots.

It shall then revert to monitoring for DSBs in timeslot 1 of all frames (except any frames in which it is transmitting); for example, the master DM-MS may send a DM-PRE ACCEPT message or a DSB indicating that it is re-starting short data transmission.

- b) The gateway shall monitor timeslot 1 of frame 18, and timeslot 3 of all frames, for DSBs transmitted by the master DM-MS (except any timeslots in which the gateway is transmitting or linearizing). For example, the master DM-MS may send a DM-SDS OCCUPIED message in frames 6, 12 and 18; or it may send a DM-PRE ACCEPT message in any frame.

NOTE 1: For a DM-REP/GATE, requirements a) and b) refer to timeslots on the master link.

Also, during the SCH/F frames for a fragmented DM-SDS UDATA or DM-SDS DATA message, and in the preceding frame, a DM-REP/GATE shall monitor timeslot 3 of frames 2, 5, 8, 11, 14 and 17 on the slave link for DSBs carrying pre-emption requests. Following the re-transmission on the master link of a pre-emption request, the DM-REP/GATE shall continue to obey the monitoring procedures until it receives a DM-PRE ACCEPT message from the master. (The DM-PRE ACCEPT message, if sent, will be in a DSB).

NOTE 2: Monitoring for short data fragments (and, for a DM-REP/GATE, for pre-emption requests and DM-PRE ACCEPT messages) may take precedence over TMO requirements to transmit and/or receive on the TM channel. This may apply if the DM-MS used an arbitrary channel timing when sending the short data message.

13.4.4.10 DM channel following pre-emption or changeover acceptance by gateway

After transmitting DM-GPRE ACCEPT, DM-GTX ACCEPT or DM-TX ACCEPT messages, or DM-PRE ACCEPT messages for short data within the ongoing call, the gateway shall monitor for a DSB in at least timeslots 1 and 3 of the frames allocated for call set-up DSBs transmitted from the new master DM-MS (setting up a circuit mode call transaction or short data message as appropriate).

NOTE 1: For a DM-REP/GATE, this requirement refers to timeslots on the master link.

NOTE 2: Improved operation may be achieved if the gateway also monitors timeslots 2 and 4 when practicable.

NOTE 3: In the case that the gateway fails to receive a call set-up message (or a short data DSB) from the pre-empting DM-MS, layer 3 usually issues a GMC-CONFIGURE request primitive indicating a state change to reservation as master; otherwise it may send DM-SETUP.

After transmitting DM-PRE ACCEPT messages for a new call pre-emption, the gateway shall enter idle mode and shall perform the idle mode channel surveillance procedures defined in clause 13.4.2.2 (e.g. monitoring the DM RF carrier in order to detect any DSBs present).

NOTE 4: After entering idle mode, if the gateway receives call set-up signalling containing its own 10-bit gateway address then it may accept the call set-up (provided that it has not seen the channel become busy in the interim time).

13.4.4.11 DM channel following pre-emption acceptance by a master DM-MS

After receiving a DM-PRE ACCEPT from the master DM-MS, a DM-REP/GATE shall continue to monitor master link timeslots 1 and 3 during the master DM-MS's frame countdown and shall re-transmit any received messages on the slave link.

After the frame countdown for a DM-PRE ACCEPT message, sent by a master DM-MS and accepting a DM-MS's pre-emption for a circuit mode transaction within the ongoing call, the gateway (either a DM-GATE or DM-REP/GATE) shall monitor for a DSB in at least timeslots 1 and 3 of the following frames for DM-GTX REQUEST messages from the pre-empting DM-MS (on the slave link, for a DM-REP/GATE). If the gateway does not receive a DM-GTX REQUEST message within a time DT268 then it shall start sending DM-RESERVED messages as master of the channel.

NOTE 1: Improved operation may be achieved if the gateway also monitors timeslots 2 and 4 when practicable.

After the frame countdown for a DM-PRE ACCEPT message, sent by a master DM-MS and accepting a DM-MS's pre-emption for a short data transaction within the ongoing call, the gateway (either a DM-GATE or DM-REP/GATE) shall monitor for a DSB in at least timeslots 1 and 3 of the following frames for short data set-up DSBs from the pre-empting DM-MS (on the master link, for a DM-REP/GATE). If the gateway does not receive a short data set-up DSB within a time DT269 then it shall start sending DM-RESERVED messages as master of the channel.

NOTE 2: Improved operation may be achieved if the gateway also monitors timeslots 2 and 4 when practicable.

After the frame countdown for a DM-PRE ACCEPT message, sent by a master DM-MS and accepting a DM-MS's new call pre-emption, the gateway (either a DM-GATE or DM-REP/GATE) shall enter idle mode and shall perform the idle mode channel surveillance procedures.

NOTE 3: After entering idle mode, if the gateway receives call set-up signalling containing its own 10-bit gateway address then it may accept the call set-up (provided that it has not seen the channel become busy in the interim time).

13.4.4.12 DM channel following pre-emption request generated by gateway

Following the transmission of a pre-emption request to a master DM-MS, a gateway shall monitor timeslots 1 and 3 in the following frames (except those frames in which it is transmitting or linearizing) to determine the result of its pre-emption request. The response to the pre-emption request may be sent by the master DM-MS using either a DSB or a DNB with slot flag set; refer to clause 8.5.7.

NOTE 1: For a DM-REP/GATE, this requirement refers to timeslots on the master link.

NOTE 2: Monitoring for the result of a pre-emption request may take precedence over TMO requirements to transmit and/or receive on the TM channel. This may apply if there has been a TMO slot numbering or slot timing change. It may also apply if a DM-MS used an arbitrary channel timing when sending a short data message.

13.4.4.13 Gateway as master in registration phase

During a registration phase the gateway shall monitor timeslot 3 for a DSB containing registration or pre-emption request signalling. The gateway shall conduct this monitoring in all frames except frames 3, 6, 12 and 18, and any frames in which it is transmitting DM-PRE ACCEPT.

NOTE: For a DM-REP/GATE, this requirement refers to timeslots on the slave link.

13.4.4.14 Gateway as master during registration cancellation

After transmission of DM-REGISTER CANCEL messages, the gateway shall monitor for a DSB in at least timeslots 1 and 3 of the frames assigned for acknowledgement messages from the addressed DM-MS.

NOTE 1: For a DM-REP/GATE, this requirement refers to timeslots on the slave link.

NOTE 2: Improved operation may be achieved if the gateway also monitors timeslots 2 and 4 when practicable.

13.4.5 Transmission of layer 3 messages by layer 2

13.4.5.1 Transmission of C-plane messages by layer 2

The gateway layer 2 on receiving a GMA-UNITDATA request from layer 3 shall, dependent upon the message type contained within the GMA-UNITDATA request and the current gateway state, use the following procedures to send the message. Refer also to clause 13.5.

NOTE 1: The following transmission procedures apply only when practicable. In case of conflict of requirements, TMO requirements may take precedence over DM transmission requirements (in which case the gateway transmits as specified, but only in those DM slots for which there is no conflict).

NOTE 2: If announcing a slot numbering change (see clause 13.4.7.15), transmission of DSBs in timeslot 1 and timeslot 3 of the old numbering may take precedence over TMO requirements to transmit and/or receive on the TM channel.

NOTE 3: For a DM-REP/GATE, the message is sent on the slave link unless noted otherwise.

NOTE 4: A DM-GATE or type 1A DM-REP/GATE transmits on the selected DM RF carrier. A type 1B DM-REP/GATE transmits on the DM downlink RF carrier f_2 .

13.4.5.1.1 Transmitting DM-SETUP and DM-SETUP PRES

GMA-UNITDATA request message type: DM-SETUP

DM-SETUP PRES

Channel condition:

Gateway idle – channel free

MAC PDU type:

DMAC-SYNC

A gateway which is currently in idle mode shall, having determined that the current state of DM channel is free, send the DM-SETUP or DM-SETUP PRES message using a DSB. The gateway shall send the message in timeslots 1 and 3 of frames FN and FN+1 up to a maximum of FN+3, where FN is the current value of the gateway's DM frame counter. The gateway shall also send the message in timeslots 2 and 4 in each of the signalling frames when practicable (i.e. when it does not conflict with TMO requirements) and should include a sequence of 6 DSBs sent as 3 DSBs in the same 3 timeslots of 2 consecutive frames, except possibly when a TMO requirement to transmit is not known when the first DSB is sent. The number of frames in which the message is sent shall be indicated by the frame countdown element value detailed in clause 13.4.7.2.

NOTE: The gateway only sends the message in timeslots 2 and 4 when practicable. For example, a DM-GATE may not be able to transmit in DM timeslot 2 since it will be receiving the TM downlink slot. If the gateway knows it has to transmit on TMO it should delay its first transmission or use more repeats.

GMA-UNITDATA request message type: DM-SETUP

DM-SETUP PRES

Channel condition:

Gateway active as master in channel reservation

Set-up after pre-emption

MAC PDU type:

DMAC-SYNC

If the gateway is currently operating as master on a reserved channel, or if it has become master after a successful pre-emption procedure, then it shall send the DM-SETUP or DM-SETUP PRES message using a DSB. The gateway shall send the message in timeslots 1 and 3 of frame FN and FN+1 up to a maximum of FN+3, where FN is the current value of the gateway's DM frame counter. The gateway shall also send the message in timeslots 2 and 4 in each of the signalling frames when practicable. The number of frames in which the message is sent shall be indicated by the frame countdown element value.

13.4.5.1.2 Transmitting DM-CONNECT ACK

GMA-UNITDATA request message type: DM-CONNECT ACK

Channel condition: Gateway active as master in channel reservation

MAC PDU type: DMAC-SYNC

The gateway layer 3 having received a DM-CONNECT message from a slave DM-MS shall, after through connection by the SwMI, send a DM-CONNECT ACK message. The gateway layer 2 shall transmit the message using a DSB, in timeslots 1 and 3 of at least one frame; it may also transmit the message in timeslots 2 and 4 in each of the signalling frames. The message shall contain the frame countdown element detailed in clause 13.4.7.2 to indicate when traffic transmissions shall begin.

NOTE 1: Transmission of the DM-CONNECT ACK message may take precedence over TMO requirements to transmit and/or receive on the TM channel. This may apply if there has been a TMO slot numbering or slot timing change.

NOTE 2: When the gateway sends DM-CONNECT ACK, it should not send the message in frames where the message may collide with transmissions from the slave DM-MS. This applies to transmission of DM-CONNECT ACK after receiving the first DM-CONNECT from the slave (as defined in clause 13.5.6.2 procedure g). It also applies if the gateway re-sends DM-SETUP PRES during the call set-up phase to extend the DM call set-up time (DM-MS timer DT307) and then receives a D-CONNECT ACKNOWLEDGEMENT PDU from the SwMI; in this case the gateway should wait until after the frames where the DM-CONNECT message may be sent before it sends the DM-CONNECT ACK message.

13.4.5.1.3 Transmitting DM-RELEASE

GMA-UNITDATA request message type: DM-RELEASE

Channel condition: Gateway active as master in channel occupation

Gateway active as master in channel reservation

MAC PDU type: DMAC-DATA

DMAC-SYNC

The gateway shall send the DM-RELEASE message using either a DNB with the slot flag set (for timeslot 1 of frames 1 to 17 during occupation) or a DSB. The gateway shall send the DM-RELEASE message in timeslot 1 in at least two frames. It shall also send the DM-RELEASE message, using a DSB, in each corresponding timeslot 3 unless it is sending DM-PRE ACCEPT or this is a linearization frame. The frame countdown element shall be used to indicate when the channel will be released.

The transmission of a DM-RELEASE message in timeslot 1 may in some cases be combined with a DM-PRE ACCEPT message within the same burst.

NOTE: Transmission of the DM-RELEASE message may take precedence over TMO requirements to transmit and/or receive on the TM channel. This may apply if there has been a TMO slot numbering or slot timing change.

13.4.5.1.4 Transmitting DM-OCCUPIED

GMA-UNITDATA request message type: DM-OCCUPIED

Channel condition: Gateway active as master in channel occupation

MAC PDU type: DMAC-SYNC

During the transmission of traffic in circuit mode occupation, the gateway shall send a DM-OCCUPIED message using a DSB in timeslot 3 of frames 6 and 12 and timeslots 1 and 3 of frame 18 (see note 2). The gateway layer 2 shall continue to send the DM-OCCUPIED message until layer 3 requests transmission of a DM-TX CEASED or DM-RELEASE message. After transmitting the requisite number of DM-TX CEASED messages the gateway layer 2 normally begins sending the DM-RESERVED signal.

NOTE 1: For call set-up without presence check, the transmission of DM-OCCUPIED does not start until after the transmission of the DM-SETUP messages. For call set-up with presence check, the transmission of DM-OCCUPIED does not start until after the transmission of the DM-CONNECT ACK messages.

NOTE 2: When appropriate, the gateway is not precluded from sending the presence signal, indicating occupation, in timeslot 3 of frames 6 and 12 and timeslots 1 and 3 of frame 18 instead of sending DM-OCCUPIED (e.g. if it needs to update the validity time for DM-MSs on the channel).

Gateway designers should note that a receiving slave DM-MS switches out of traffic mode if a time DT221 elapses without receipt of a DM-OCCUPIED message for the call (see clause 8.6). Also a DM-MS cannot join a call by late entry upon reception of the presence signal. Therefore frequent replacement of DM-OCCUPIED by the presence signal is not recommended.

13.4.5.1.5 Transmitting DM-TX CEASED

GMA-UNITDATA request message type: DM-TX CEASED

Channel condition: Gateway active as master in channel occupation

MAC PDU type: DMAC-DATA

DMAC-SYNC

The gateway shall send the DM-TX CEASED message using a DNB with the slot flag set in timeslot 1 in the frames following the last traffic frame (or using a DSB for a transmission in timeslot 1 of frame 18). Also:

- it shall send the DM-TX CEASED message, using a DSB, in the corresponding timeslot 3 for a frame 6, 12 or 18, unless it is sending DM-PRE ACCEPT;
- it should send the DM-TX CEASED message, using a DSB, in the corresponding timeslot 3 of the other transmission frames – unless it is sending DM-PRE ACCEPT or this is a linearization frame;
- if announcing a timing change, it shall send the DM-TX CEASED message, using a DSB, in the corresponding timeslot 3 of each transmission frame – unless it is sending DM-PRE ACCEPT or this is a linearization frame.

The DM-TX CEASED message shall be sent in several frames as indicated by the frame countdown element as detailed in clause 13.4.7.2.

NOTE 1: Transmission of DM-TX CEASED in timeslot 1 (and in timeslot 3 of frame 6, 12 or 18) may take precedence over TMO requirements to transmit and/or receive on the TM channel. This may apply if there has been a TMO slot numbering or slot timing change.

DM-TX CEASED and DM-RESERVED messages indicate the reservation time remaining, in units of 6 frames, measured to the end of a frame 6, 12 or 18. If sent in a frame 6, 12 or 18, the reservation time remaining shall be measured from the end of that frame. If sent in a frame other than frame 6, 12 or 18, the reservation time remaining shall be measured from the end the next occurring frame 6, 12 or 18. If the transmission of a DM-TX CEASED message (or a multiple-frame transmission of DM-RESERVED) crosses a frames 6, 12 or 18, the master MS shall decrement the reservation time remaining element in the DM-TX CEASED (or DM-RESERVED) messages sent after that frame 6, 12 or 18.

NOTE 2: The above definition means that, if the transmission of DM-TX CEASED (or DM-RESERVED) crosses a frame 6, 12 or 18, not all the messages contain the same value of the reservation time remaining element. However they all indicate the same reservation period.

NOTE 3: It is not possible for the gateway to set the reservation time remaining equal to 000000_2 in the first transmission frame of DM-TX CEASED (or a multiple-frame transmission of DM-RESERVED) if the transmission will cross a frame 6, 12 or 18.

If the gateway is terminating its traffic transmission because it is accepting a pre-emption request then it shall set the "reservation time remaining" element to 001111_2 in the DM-TX CEASED messages (or in the final DM-TX CEASED message if the transmission crosses a frame 6, 12 or 18). (However, the gateway layer 2 does not send reservation messages unless it receives a GMC-CONFIGURE request primitive from layer 3 indicating a state change to reservation as master).

13.4.5.1.6 Transmitting response to DM-TX REQUEST

GMA-UNITDATA request message type: DM-TX ACCEPT

DM-REJECT

Channel condition: Gateway active as master in channel reservation

MAC PDU type: DMAC-SYNC

The gateway layer 3 having received a DM-TX REQUEST message from a slave DM-MS may send either a DM-TX ACCEPT or DM-REJECT message. The gateway layer 2 shall transmit the message using a DSB in timeslot 1 in at least two frames for DM-TX ACCEPT, or at least one frame for DM-REJECT. For DM-TX ACCEPT, the gateway layer 2 should send the message also in each corresponding timeslot 3 (and may send the message in timeslots 2 and 4). The number of frames in which the message is sent shall be indicated by the frame countdown element.

13.4.5.1.7 Transmitting DM-PREEMPT

GMA-UNITDATA request message type: DM-PREEMPT

Channel condition: Gateway active as slave in channel occupation

MAC PDU type: DMAC-SYNC

The gateway shall send the DM-PREEMPT message using a DSB in timeslot 3 of frames 1, 7 and 13 of a multiframe (and optionally in other frames), using the procedure described in clause 13.5.7.3.

NOTE 1: For a DM-REP/GATE, the DM-PREEMPT message is sent on the master link.

NOTE 2: Transmission of the DM-PREEMPT message may take precedence over TMO requirements to transmit or receive on the TM channel. This may apply if there has been a TMO slot numbering or slot timing change. It may also apply if a DM-MS used an arbitrary channel timing when sending a short data message.

GMA-UNITDATA request message type: DM-PREEMPT

Channel condition: Gateway idle – channel occupied or reserved

MAC PDU type: DMAC-SYNC

A gateway in idle mode having acquired the required synchronization and call related information from the current master shall send the DM-PREEMPT message using a DSB. It shall send the message and any retransmissions using the DM-MS random access request procedure described in clause 8.5.7.3 of the part of EN 300 396 appropriate to the current master's call.

NOTE 3: When performing this procedure the gateway uses the DM-MS random access request procedure. Therefore a type 1B DM-REP/GATE transmits on the DM RF carrier appropriate to DM-MS transmission for the ongoing call and then monitors for a response on the DM RF carrier appropriate to DM-MS reception for the ongoing call.

NOTE 4: Transmission of the DM-PREEMPT message (and monitoring for the result) may take precedence over TMO requirements to transmit and/or receive on the TM channel.

GMA-UNITDATA request message type: DM-PREEMPT

Channel condition: Gateway idle – channel in registration phase

MAC PDU type: DMAC-SYNC

A gateway in idle mode having acquired the required synchronization from the other gateway shall send the DM-PREEMPT message using a DSB (and containing the other gateway's 10-bit address in the "gateway address" element). It shall send the message and any retransmissions using the DM-MS procedure described in clause 8.5.8.2.

NOTE 5: When performing this procedure the gateway uses the DM-MS procedure. Therefore a type 1B DM-REP/GATE transmits on the DM RF carrier appropriate to DM-MS transmission for the ongoing registration phase and then monitors for a response on the DM RF carrier appropriate to DM-MS reception for the ongoing registration phase.

NOTE 6: Transmission of the DM-PREEMPT message (and monitoring for the result) may take precedence over TMO requirements to transmit and/or receive on the TM channel.

13.4.5.1.8 Transmitting response to DM-PREEMPT

GMA-UNITDATA request message type: DM-PRE ACCEPT

DM-REJECT

Channel condition:

Gateway active as master in channel occupation

Gateway active as master in channel reservation

Gateway active as master in registration phase

MAC PDU type:

DMAC-DATA

DMAC-SYNC

The gateway layer 3 having received a DM-PREEMPT message and decided to permit the pre-emption shall send a DM-PRE ACCEPT message. The gateway layer 2 shall transmit the message using a DSB during reservation or short data occupation or during a registration phase, or using a DNB with the slot flag set during circuit mode occupation (for frames 1 to 17), in timeslot 1 in at least two frames. It shall send the message also in each corresponding timeslot 3 using a DSB unless this is a linearization frame (and may send the message in timeslots 2 and 4). The number of frames in which the message is sent shall be indicated by the frame countdown element.

The pre-emption request may be rejected using a DM-REJECT message. The gateway layer 2 need not repeat the DM-REJECT message.

NOTE: Transmission of DM-PRE ACCEPT in response to a new call pre-emption may take precedence over TMO requirements to transmit and/or receive on the TM channel.

13.4.5.1.9 Transmitting DM-SDS UDATA and DM-SDS DATA

GMA-UNITDATA request message type: DM-SDS UDATA

DM-SDS DATA

Channel condition:

Gateway idle – channel free

MAC PDU type:

DMAC-SYNC, FRAG, END

A gateway which is currently in idle mode shall, having determined that the current state of DM channel is free, send the SDS call set-up message using a DSB. The gateway shall send the SDS call set-up DSB in timeslots 1 and 3 of frames FN and FN+1 up to a maximum of FN+3, where FN is the current value of the gateway's DM frame counter. The gateway shall also send the SDS call set-up DSB in timeslots 2 and 4 in each of the set-up signalling frames when practicable (i.e. when it does not conflict with TMO requirements) and should include a sequence of 6 DSBs sent as 3 DSBs in the same 3 timeslots of 2 consecutive frames, except possibly when a TMO requirement to transmit is not known when the first DSB is sent. The number of frames in which the DSB is sent shall be indicated by the frame countdown element value.

Following the transmission of the SDS call set-up DSBs the gateway shall continue to send the SDS message in timeslot 1 of the next frame in the range 1 to 17, using a DNB. It is possible to send the first part of the SDS message in the call set-up frames, so this part of the message is sent several times. However the remainder (if any) of the SDS message is sent in timeslot 1 of the subsequent traffic frames and shall not be repeated within the transmission.

For DM-SDS UDATA, the complete SDS transmission may be repeated immediately (without re-checking that the channel is free).

GMA-UNITDATA request message type: DM-SDS UDATA

DM-SDS DATA

Channel condition:

Gateway active as master in channel reservation

Short data sent after pre-emption

Immediate retransmission of DM-SDS DATA

MAC PDU type:

DMAC-SYNC, FRAG, END

If the gateway is currently operating as master on a reserved channel, or if it has become master after a successful pre-emption procedure, or if it is sending an immediate retransmission of a DM-SDS DATA message, then it shall send the SDS set-up message using a DSB. The gateway shall send the SDS set-up DSB in timeslots 1 and 3 of frame FN and FN+1 up to a maximum of FN+3, where FN is the current value of the gateway's DM frame counter; it shall also send the SDS set-up DSB in timeslots 2 and 4 in each of the set-up signalling frames when practicable. It shall then send the remaining fragments of the SDS message as described above.

For DM-SDS UDATA, the complete SDS transmission may be repeated immediately.

GMA-UNITDATA request message type: DM-SDS UDATA

Channel condition:

Gateway active as master in channel occupation

MAC PDU type:

DMAC-DATA, END

During the transmission of traffic in circuit mode occupation, the gateway may send the DM-SDS UDATA message using a DNB with the slot flag set (i.e. by stealing) in timeslot 1 of a frame in the range 1 to 17. The message may be sent in a single half slot, or may be fragmented between the two half slots of one timeslot. It may be repeated when convenient.

13.4.5.1.10 Transmitting response to DM-SDS DATA

GMA-UNITDATA request message type: DM-SDS ACK

DM-REJECT

Channel condition:

Gateway active as slave in channel occupation

MAC PDU type:

DMAC-SYNC, END

The gateway having received a DM-SDS DATA message may send a DM-SDS ACK or DM-REJECT message using a DSB, in timeslots 1 and/or 3 in the appropriate frame(s); see clause 13.5.6.2. The number of frames in which the DSB is sent shall be indicated by the frame countdown element.

A DM-SDS ACK may be fragmented, with one fragment following the DMAC-SYNC PDUs. The final fragment (DMAC-END PDU) shall be sent once, in a timeslot 1, using a DNB.

NOTE 1: For a DM-REP/GATE, the DM-SDS ACK message is sent on the master link.

NOTE 2: Transmission of a response to a DM-SDS DATA message may take precedence over TMO requirements to transmit and/or receive on the TM channel. This may apply if the DM-MS used an arbitrary channel timing when sending the DM-SDS DATA message.

13.4.5.1.11 Transmitting DM-INFO

GMA-UNITDATA request message type: DM-INFO

Channel condition:

Gateway active as master in channel occupation

MAC PDU type:

DMAC-DATA, END

During the transmission of traffic in circuit mode occupation, the gateway may send the DM-INFO message using a DNB with the slot flag set (i.e. by stealing) in timeslot 1 of a frame in the ranges 1 to 17. The message may be sent in a single half slot, or may be fragmented between the two half slots of one timeslot. It may be repeated when convenient.

13.4.5.1.12 Transmitting response to DM-GSETUP

GMA-UNITDATA request message type: DM-GACK

DM-GCONNECT

Channel condition: Gateway active as master in channel reservation

MAC PDU type: DMAC-SYNC

The gateway layer 3 having received a DM-GSETUP message from a calling DM-MS may send a DM-GACK message. If the gateway layer 3 issues a final response (e.g. DM-GCONNECT) before layer 2 has started transmitting the DM-GACK message then layer 2 may discard the DM-GACK. Otherwise layer 2 shall transmit the message using a DSB, in timeslots 1 and 3 of at least one frame. It should also transmit the message in timeslots 2 and 4 in each of the signalling frames when practicable.

The number of frames in which the DM-GACK message may be sent shall be indicated by the frame countdown element. However, the frame countdown process for the DM-GACK message may be interrupted (i.e. cut short). For example, if layer 3 issues a DM-GCONNECT message then layer 2 should stop transmitting the DM-GACK message irrespective of the frame countdown value and start sending the DM-GCONNECT message.

NOTE 1: In addition to responding to the calling DM-MS's DM-GSETUP message, the DM-GACK message may perform the function of a channel reservation message e.g. inviting pre-emption requests and defining the reservation time remaining.

NOTE 2: For a DM-REP/GATE, the DM-GACK message may be the first message that can be received by other DM-MSs on the channel. Therefore, in order that the other DM-MSs can detect the channel as busy, it is recommended that the DM-REP/GATE sends the DM-GACK message in at least three timeslots of at least two frames (unless the frame countdown process is cut short).

After through connection by the SwMI, the gateway layer 3 shall send a DM-GCONNECT message. The gateway layer 2 shall transmit the message using a DSB, in timeslots 1 and 3 of at least two frames. It may also transmit the message in timeslots 2 and 4 in each of the signalling frames (e.g. if changing the slot numbering). The number of frames in which the message is sent shall be indicated by the frame countdown element.

NOTE 3: If announcing a timing adjustment in a DM-GACK message (see clause 13.4.7.16), transmission of DM-GACK may take precedence over TMO requirements to transmit and/or receive on the TM channel. This may apply if the DM-MS used an arbitrary channel timing when sending the DM-GSETUP message.

13.4.5.1.13 Transmitting response to DM-GTX REQUEST

GMA-UNITDATA request message type: DM-GACK

DM-GTX ACCEPT

DM-GREJECT

Channel condition: Gateway active as master in channel reservation

MAC PDU type: DMAC-SYNC

The gateway layer 3 having received a DM-GTX REQUEST from a slave DM-MS may send a DM-GACK message. If the gateway layer 3 issues a final response (DM-GTX ACCEPT or DM-GREJECT) before layer 2 has started transmitting the DM-GACK message then layer 2 may discard the DM-GACK. Otherwise layer 2 shall transmit the message using a DSB in timeslot 1 in at least one frame. It may send the message also in each corresponding timeslot 3 using a DSB.

The number of frames in which the DM-GACK message may be sent shall be indicated by the frame countdown element. However, the frame countdown process may be interrupted. For example, if layer 3 issues a DM-GTX ACCEPT message then layer 2 should stop transmitting the DM-GACK message irrespective of the frame countdown value and start sending the DM-GTX ACCEPT message.

On acceptance of the transmission request by the SwMI, the gateway layer 3 shall send a DM-GTX ACCEPT message. The gateway layer 2 shall transmit the message using a DSB in timeslot 1 in at least two frames. It should send the message also in each corresponding timeslot 3 using a DSB (and may send the message in timeslots 2 and 4). The number of frames in which the message is sent shall be indicated by the frame countdown element.

The transmission request may be rejected using a DM-GREJECT message. The gateway layer 2 need not repeat the DM-GREJECT message.

13.4.5.1.14 Transmitting response to DM-GPREEMPT

GMA-UNITDATA request message type: DM-GACK

DM-GPRE ACCEPT

DM-GREJECT

Channel condition:

Gateway active as master in channel occupation

Gateway active as master in channel reservation

MAC PDU type:

DMAC-DATA

DMAC-SYNC

The gateway layer 3 having received a DM-GPREEMPT message from a slave DM-MS may send a DM-GACK message. If the gateway layer 3 issues a final response (DM-GPRE ACCEPT or DM-GREJECT) before layer 2 has started transmitting the DM-GACK message then layer 2 may discard the DM-GACK. Otherwise, during reservation or short data occupation, layer 2 shall transmit the message using a DSB in timeslot 1 in at least one frame, and may transmit the message also in each corresponding timeslot 3; during circuit mode occupation, layer 2 may transmit the message in timeslot 1 (using a DNB for frames 1 to 17) and/or timeslot 3 (using a DSB) in at least one frame – see clause 13.5.7.2.3.

The number of frames in which the DM-GACK message may be sent shall be indicated by the frame countdown element. However, the frame countdown process may be interrupted. For example, if layer 3 issues a DM-GPRE ACCEPT message then layer 2 should stop transmitting the DM-GACK message irrespective of the frame countdown value and start sending the DM-GPRE ACCEPT message.

On acceptance of the pre-emption request by the SwMI, the gateway layer 3 shall send a DM-GPRE ACCEPT message. The gateway layer 2 shall transmit the message using a DSB during reservation or short data occupation, or using a DNB with the slot flag set during circuit mode occupation (for frames 1 to 17), in timeslot 1 in at least two frames. It should send the message also in each corresponding timeslot 3 using a DSB (and may send the message in timeslots 2 and 4). The number of frames in which the message is sent shall be indicated by the frame countdown element.

The pre-emption request may be rejected using a DM-GREJECT message. The gateway layer 2 need not repeat the DM-GREJECT message.

13.4.5.1.15 Transmitting DM-GRELEASE

GMA-UNITDATA request message type: DM-GRELEASE

Channel condition:

Gateway active as slave in channel occupation

MAC PDU type:

DMAC-SYNC

The gateway shall send the DM-GRELEASE message using a DSB in timeslot 3 of frames 1, 7 and 13 of a multiframe (and optionally in other frames), using the procedure described in clause 13.5.7.3.

NOTE 1: For a DM-REP/GATE, the DM-GRELEASE message is sent on the master link.

NOTE 2: Transmission of the DM-GRELEASE message may take precedence over TMO requirements to transmit or receive on the TM channel. This may apply if there has been a TMO slot numbering or slot timing change.

13.4.5.1.16 Transmitting response to registration request

GMA-UNITDATA request message type: DM-GREGISTER ACCEPT

DM-GREGISTER REJECT

Channel condition: Gateway active as master in registration phase

MAC PDU type: DMAC-SYNC

If the gateway is active as master in a registration phase and receives a solicited registration request from a DM-MS then the gateway layer 3 shall send either a DM-GREGISTER ACCEPT or DM-GREGISTER REJECT message. The gateway layer 2 shall transmit the message using a DSB in timeslot 1 in at least one frame; see clause 13.5.8.

GMA-UNITDATA request message type: DM-GREGISTER ACCEPT

DM-GREGISTER REJECT

Channel condition: Gateway active as slave in channel occupation

MAC PDU type: DMAC-SYNC

The gateway layer 3 having received an unsolicited registration request from a DM-MS shall send either a DM-GREGISTER ACCEPT or DM-GREGISTER REJECT message. The gateway layer 2 shall transmit the message using a DSB, in timeslots 1 and/or 3 in the appropriate frame(s); see clause 13.5.6.2. The number of frames in which the message is sent shall be indicated by the frame countdown element.

NOTE 1: For a DM-REP/GATE, the acceptance or rejection of an unsolicited registration message is sent on the master link.

NOTE 2: Transmission of a response to an unsolicited registration request may take precedence over TMO requirements to transmit and/or receive on the TM channel. This may apply if the DM-MS used an arbitrary channel timing when sending the DM-GREGISTER REQUEST message.

13.4.5.1.17 Transmitting registration cancellation

GMA-UNITDATA request message type: DM-GREGISTER CANCEL

Channel condition: Gateway idle – channel free

MAC PDU type: DMAC-SYNC

A gateway which is currently in idle mode shall, having determined that the current state of DM channel is free, send the DM-GREGISTER CANCEL message using a DSB. The gateway shall send the message in timeslots 1 and 3 of frames FN and FN+1 up to a maximum of FN+3, where FN is the current value of the gateway's DM frame counter. The gateway shall also send the message in timeslots 2 and 4 in each of the signalling frames when practicable (i.e. when it does not conflict with TMO requirements) and should include a sequence of 6 DSBs sent as 3 DSBs in the same 3 timeslots of 2 consecutive frames, except possibly when a TMO requirement to transmit is not known when the first DSB is sent. The number of frames in which the message is sent shall be indicated by the frame countdown element value.

13.4.5.2 Transmission of U-plane messages by layer 2

When master during circuit mode occupation, the gateway DM layer 2 on receiving a GMD-UNITDATA request primitive from the U-plane converter shall perform the procedures as defined in clause 13.6.4.

13.4.6 Transmission of layer 2 messages

13.4.6.1 Layer 2 messages sent in DMAC-SYNC PDU

Some signalling messages are generated and transmitted by the gateway's DM layer 2 without the intervention of layer 3. The following procedures detail how such signalling is handled.

13.4.6.1.1 Transmitting DM-RESERVED

Message type:	DM-RESERVED
Channel condition:	Gateway active as master in channel reservation
MAC PDU type:	DMAC-SYNC

During channel reservation the gateway shall send DM-RESERVED messages using a DSB in timeslots 1 and 3 of frames 6, 12 and 18 (see note):

- For channel reservation during call set-up through the gateway, transmission of the DM-RESERVED message shall continue throughout the set-up reservation period e.g. until the gateway sends a DM-GCONNECT, DM-SETUP, DM-CONNECT ACK, DM-PRE ACCEPT or DM-RELEASE message or the channel reservation period expires.
- For channel reservation after a call transaction, transmission of the DM-RESERVED message shall continue until either the gateway resumes transmission (for a circuit mode call transaction or to send a short data message as a transaction within the circuit mode call) or the gateway sends a DM-GTX ACCEPT, DM-GPRE ACCEPT, DM-TX ACCEPT, DM-PRE ACCEPT or DM-RELEASE message or the channel reservation period ends.

The gateway may also send DM-RESERVED messages in timeslots 1 and 3 of other frames e.g. at the start of a reservation period during call set-up by the gateway, or when the gateway becomes master of the channel after receiving DM-TX CEASED messages from a DM-MS, or after short data has been sent as a transaction within a circuit mode call, or after a timing change announcement.

The gateway may also send DM-RESERVED messages in timeslots 2 and 4 when appropriate e.g. if it is changing the slot numbering.

The channel reservation signal shall contain an element indicating how much longer the channel may remain reserved. The final DM-RESERVED messages sent on expiry of the channel reservation period shall indicate the end of the reservation time (element "reservation time remaining" set to 000000₂).

During a reservation period, the gateway layer 2 shall increase the current value of the "reservation time remaining" element in DM-RESERVED messages if instructed by layer 3 to extend the reservation period (GMC-CONFIGURE request primitive).

The gateway shall use the "requests bitmap" element in the DM-RESERVED message to indicate in which frames (timeslot 3) slave DM-MSs may send random access requests.

NOTE: When appropriate, the gateway may send the presence signal, indicating reservation, in timeslots 1 and 3 of frames 6, 12 and 18 instead of sending DM-RESERVED (e.g. if it needs to update the validity time for DM-MSs on the channel).

13.4.6.1.2 Transmitting DM-SDS OCCUPIED

Message type:	DM-SDS OCCUPIED
Channel condition:	Gateway active as master in channel occupation
MAC PDU type:	DMAC-SYNC

During the transmission of SCH/F for a DM-SDS DATA or DM-SDS UDATA message, the gateway shall send a DM-SDS OCCUPIED message using a DSB in timeslot 3 of frames 6 and 12 and timeslots 1 and 3 of frame 18 (see note). It shall not send DM-SDS OCCUPIED during the period when it is waiting for a DM-SDS ACK following the transmission of a DM-SDS DATA message.

NOTE: When appropriate, the gateway is not precluded from sending the presence signal, indicating occupation, in timeslot 3 of frames 6 and 12 and timeslots 1 and 3 of frame 18 instead of sending DM-SDS OCCUPIED (e.g. if it needs to update the validity time for DM-MSs on the channel).

13.4.6.1.3 Transmitting DM-TIMING ACK

Message type:	DM-TIMING ACK
Channel condition:	Gateway active as master in channel reservation
MAC PDU type:	DMAC-SYNC

During channel reservation the gateway may send the DM-TIMING ACK message to announce a timing change on the DM channel. The gateway shall transmit the message using a DSB in timeslot 1 in at least two frames. It should send the message also in each corresponding timeslot 3. The frame countdown element shall be used to indicate when the timing change will occur.

NOTE: Transmission of the DM-TIMING ACK message may take precedence over TMO requirements to transmit and/or receive on the TM channel.

13.4.6.2 Gateway presence signal

13.4.6.2.1 Channel free

As an option, the gateway may transmit a presence signal – the DPRES-SYNC PDU – periodically on the channel during the time when the gateway is otherwise idle and the channel is perceived by the gateway as being free. If used on a free channel, the presence signal shall be sent in a DSB, in timeslots 1 and 3 of DN263 consecutive frames, using the "frame countdown" element to indicate the number of frames in which the message is being repeated. It shall also be sent in timeslots 2 and 4 in each of the signalling frames when practicable (i.e. when it does not conflict with TMO requirements) and should include a sequence of 6 DSBs sent as 3 DSBs in the same 3 timeslots of 2 consecutive frames, except possibly when a TMO requirement to transmit is not known when the first DSB is sent.

NOTE 1: For a DM-REP/GATE, the free-channel presence signal is sent on the slave link.

However, if the gateway observes a channel change from busy to free (e.g. at the end of the frame countdown for a transmitted or received DM-RELEASE message or if it detects the end of circuit mode reservation, SDS occupation or a registration phase) and if, within the following time DT265, it wishes to transmit a presence signal then it shall choose an integer R randomly from the range DN264 to DN265 (using a uniform distribution) and plan to start sending the presence signal after R frame durations. During the intervening time, the gateway shall continue to monitor the DM RF carrier(s) and if it detects a DSB that causes a change of DM-MAC state then it shall not transmit a presence signal on this occasion.

The following exception applies in the case of a new call pre-emption acceptance. If the gateway observes a channel change from busy to free as the result of a new call pre-emption acceptance (i.e. at the end of the frame countdown for a transmitted or received DM-PRE ACCEPT message with "new call pre-emption" set to 1 and addressed to another DM-MS or at the end of the frame countdown for a received free channel presence signal with "registration phase terminated flag" set to 1) and if, within the following time DT276, it wishes to transmit a presence signal then the gateway shall choose an integer R randomly from the range DN264 + 8 to DN265 + 8 (using a uniform distribution) and plan to start sending the presence signal after R frame durations. During the intervening time, the gateway shall continue to monitor the DM RF carrier(s) and if it detects a DSB that causes a change of DM-MAC state then it shall not transmit a presence signal on this occasion.

The minimum interval between each sequence of transmissions shall correspond to time DT263 and the maximum interval shall correspond to time DT264 (see note 2). The structure of the presence signal shall be as defined in clause 14.

NOTE 2: If the presence signal is used on a free channel, it is recommended that the gateway sends the signal at irregular intervals. This is in order to avoid repeated collisions if more than one gateway or DM-REP is sending presence signals on the channel.

If regular transmission of the free-channel presence signal is required in an application, this may be achieved by setting DT263 equal to DT264.

NOTE 3: Transmission of the free-channel presence signal is optional. In an implementation, it is recommended that the gateway is capable of sending the free-channel presence signal – though it may be disabled in an application by setting DT263 and DT264 to 0.

NOTE 4: Intervals DT263 and DT264 are measured from the start of one sequence of transmissions until the start of the next sequence of transmissions.

NOTE 5: If a type 1B DM-REP/GATE is capable of frequency full duplex operation, and if it detects call set-up signalling while it is transmitting the free-channel presence signal, then it may stop transmitting the presence signal irrespective of the frame countdown value.

The gateway presence signal indicates to receiving DM-MSs that a gateway with the specified address is switched on and within range. It may also indicate which DM-MSs are permitted to use that gateway. The presence signal is used as the timing reference when a DM-MS makes a call through the gateway.

If the gateway is not currently within range of the SwMI, it may still choose to transmit the gateway presence signal. For example, it may still wish to indicate its presence to DM-MSs or it may be offering a DM-REP function (i.e. with the "DM-REP function flag" set to 1). If it transmits the gateway presence signal when not within range of the SwMI, it shall set the "SwMI availability flag" to 0.

13.4.6.2.2 Channel in occupation

When a DM-MS is master during circuit mode occupation or during the SCH/F frames for a short data message:

- if a DM-GATE is not attempting pre-emption or sending DM-GRELEASE then it shall transmit a presence signal, indicating occupation, in timeslot 3 of frames 1, 7 and 13;
- if a DM-REP/GATE did not receive a random access request in timeslot 3 of slave link frame 5, 11 or 17, and if the DM-REP/GATE is not attempting pre-emption itself or sending DM-GRELEASE, then it shall transmit a presence signal, indicating occupation, in timeslot 3 of master link frame 7, 13 or 1 respectively;
- if a DM-REP/GATE did not receive a DSB from the master DM-MS in timeslot 1 of master link frame 18 or timeslot 3 of master link frames 6, 12 or 18 then it may send a presence signal, indicating occupation, in the corresponding slot on the slave link;
- if a DM-REP/GATE received a DM-OCCUPIED or DM-SDS OCCUPIED message from the master DM-MS in timeslot 1 of master link frame 18 or timeslot 3 of master link frames 6, 12 or 18 then, if appropriate, it is not precluded from sending a presence signal, indicating occupation, in the corresponding slot on the slave link instead of re-transmitting the master DM-MS's message (e.g. if it needs to update the validity time for DM-MSs on the channel).

NOTE 1: Concerning possible replacement of DM-OCCUPIED or DM-SDS OCCUPIED messages with a presence signal indicating occupation, DM-REP/GATE designers should note that a receiving slave DM-MS switches out of traffic mode if a time DT221 elapses without receipt of a DM-OCCUPIED message for the call (see clause 8.6). Also a DM-MS cannot join a call by late entry upon reception of the presence signal, and an idle DM-MS may perceive the channel as free and start making calls. Therefore frequent use of such replacement is not recommended.

The gateway may send the gateway presence signal during occupation in those timeslots not used within the call.

When the gateway is master during circuit mode occupation it sends DM-OCCUPIED to indicate circuit mode occupation (see clause 13.4.5.1.4). Or, when it is master during short data occupation, it sends DM-SDS OCCUPIED. However, when appropriate, it is not precluded from replacing DM-OCCUPIED or DM-SDS OCCUPIED messages with a presence signal indicating occupation.

Also a type 1B DM-REP/GATE, after receiving a call set-up DSB from a master DM-MS (on the DM uplink RF carrier f_1), may send the presence signal indicating occupation (on the DM downlink RF carrier f_2) until it starts to re-transmit the master DM-MS's set-up message on the slave link. See also note 2 of clauses 13.4.8.1.2 and 13.4.8.1.3.

When a DM-MS is master during occupation, and the master is sending a message (e.g. DM-TX CEASED or DM-RELEASE), the gateway should not send the presence signal in slot 3 during the master DM-MS's transmissions i.e. it should not send the presence signal in slot 3 if it saw the master DM-MS's message in slot 1 and should not send the presence signal during the master DM-MS's frame count-down.

NOTE 2: The requirement for the gateway not to send the presence signal in slot 3 is in order to avoid a collision with the master DM-MS's message. It also enables the gateway to monitor the channel in order to receive the master DM-MS's signalling.

NOTE 3: A gateway that is idle on a busy channel should not transmit a presence signal.

13.4.6.2.3 Channel in reservation

The gateway may send the gateway presence signal during channel reservation in those timeslots not used within the call.

The gateway usually sends DM-RESERVED in timeslots 1 and 3 of frames 6, 12 and 18 to indicate channel reservation (see clause 13.4.6.1.1). However, when appropriate, it may replace DM-RESERVED messages with a presence signal indicating reservation.

NOTE: A gateway that is idle on a busy channel should not transmit a presence signal.

13.4.6.2.4 Channel in registration phase

The gateway shall send the gateway presence signal when it wishes to announce the start of a registration phase. It shall also send the presence signal during the registration phase, as defined in clause 13.5.8.

13.4.7 General layer 2 procedures

13.4.7.1 Repeat transmissions

Many layer 3 messages are sent several times by the gateway layer 2 to improve signalling reliability. For each type of signalling message sent by a gateway, the gateway layer 2 shall know how many message transmissions are required and during transmission indicate using the "frame countdown" element how many more transmission frames remain following the current frame. The minimum and maximum numbers of transmission frames for messages sent using the frame countdown mechanism are given in annex A.

13.4.7.2 Frame countdown procedure

The gateway shall dependent upon message type set the "frame countdown" element in the signalling messages up to the maximum permitted as given in annex A. The gateway shall decrement the "frame countdown" element by 1 for each frame in which the message is sent. When the "frame countdown" element = 0 this shall indicate that this is the last frame containing this information.

13.4.7.3 Use of timers

The gateway shall use a set of timers e.g. to determine how long it should wait for a response to a random access message. The timers are listed in annex A.

13.4.7.4 Linearization

When the channel is perceived as free, the gateway may linearize its transmitter at any time (but not more frequently than once per multiframe).

When master during circuit mode occupation, the gateway may linearize in timeslot 3 of frame 3 of any multiframe. In order to enable DM-MSs to linearize, the gateway shall permit the use of timeslot 3 of frame 3 for linearization, by setting the "LCH in frame 3 flag" equal to 1 in the call set-up and occupation signalling.

When a slave (or idle) during circuit mode occupation, the gateway may only conduct linearization in timeslot 3 of frame 3 if permitted by the current master.

NOTE 1: The requirement on the master to permit linearization during circuit mode occupation may be relaxed for some types of call in future editions of the present document. Therefore, recipients have to check the setting of the "LCH in frame 3 flag".

During reservation, the gateway may linearize in timeslot 3 of frame 3 of any multiframe.

NOTE 2: This applies to all reservation periods, either during call set-up through a gateway or after a call transaction.

During a registration phase, the gateway may linearize in timeslot 3 of frame 3 of any multiframe.

NOTE 3: When permitted by the above definitions to linearize in timeslot 3 of frame 3, a DM-REP/GATE may use either the slave link or the master link.

During short data occupation, a DM-GATE may linearize in timeslot 3 of frame 3 if timeslot 1 of frame 3 is an SCH/F slot (as indicated by the "number of SCH/F slots" element in the SDS call set-up DSBs).

When master during short data occupation, a DM-REP/GATE may linearize in timeslot 3 of slave link frame 3 if timeslot 1 of slave link frame 3 is an SCH/F slot (as indicated by the "number of SCH/F slots" element in the SDS call set-up DSBs).

When a slave during short data occupation, a DM-REP/GATE may linearize in timeslot 3 of frame 3 of either the master link or the slave link as follows:

- It may linearize in timeslot 3 of frame 3 of the master link, if timeslot 1 of frame 3 is an SCH/F slot (as indicated by the "number of SCH/F slots" element in the SDS call set-up DSBs).
- It may linearize in timeslot 3 of slave link frame 3 if timeslot 1 of slave link frame 3 is an SCH/F slot – except that, for a DM-SDS UDATA message, it shall not linearize in the slave link frame containing the final SCH/F slot. Also, it may linearize in timeslot 3 of slave link frame 3 if timeslot 1 of slave link frame 4 will be an SCH/F slot.

If, for any reason, the gateway is not adequately linearized at a time when other procedures in this clause require it to transmit on the DM channel then the gateway may linearize its transmitter in the time just prior to sending the signalling; or, alternatively, it may use the first designated transmission slot for linearization instead of sending the required signalling in that slot.

NOTE 4: For example, for some modes of operation, if the gateway does not send the presence signal periodically on a free channel, it may not be appropriate for the gateway to keep linearized on a free channel. Then the gateway may use one of the procedures in the above paragraph when it needs to transmit.

NOTE 5: A DM-GATE or type 1A DM-REP/GATE linearizes on the selected DM RF carrier. A type 1B DM-REP/GATE linearizes on the DM downlink RF carrier f_2 .

13.4.7.5 Fragmentation

In the case where a signalling message from layer 3 is larger than can be accommodated within a single MAC PDU the gateway layer 2 shall subdivide and transmit the SDU in a number of fragments according to the procedures detailed in clause 13.5.4. The gateway shall indicate that fragmentation is in use by setting the appropriate flag in the DMAC-SYNC or DMAC-DATA PDU.

13.4.7.6 Fill bit indication

In the case where fill bits are added by the gateway this shall be indicated by setting the appropriate flag in the MAC PDUs as detailed in EN 300 396-3 [3], clause 8.5.5.

13.4.7.7 Use of pseudo address

In those cases where the gateway cannot or does not wish to use a TM-MS's SSI as the DM layer 2 source address, the gateway shall use a pseudo SSI as the DM layer 2 source address; refer to clause 13.5.2. The use of a pseudo SSI shall be indicated in the signalling message.

13.4.7.8 Slot flag indication

In the case of either C-plane or U-plane stealing from circuit mode traffic channel capacity, the gateway shall indicate this by setting the slot flag. Slot flag is indicated in a timeslot by changing the preamble and training sequence from that used during traffic as detailed in EN 300 396-2 [2], clause 9.

13.4.7.9 Requests bitmap

During reservation the gateway may dictate which frames, in addition to frames 2, 5, 8, 11, 14 and 17, may be used for random access messages. The gateway shall indicate those frames using the 8-bit "requests bitmap" element, which relates to frames 1, 4, 7, 9, 10, 13, 15 and 16.

13.4.7.10 Receiving the TM channel

The gateway should receive and attempt to decode the appropriate downlink channel on the selected TMO system, and should transmit when required by the SwML. TMO requirements may temporarily override both transmission and monitoring requirements on the DMO side. In some cases DM requirements may take precedence, as indicated in this clause.

13.4.7.11 Air interface encryption

When required the gateway shall implement air interface encryption using the procedures detailed in EN 300 396-3 [3], clause 8.5.3. The gateway shall indicate the use of air interface encryption using the appropriate element in the DMAC-SYNC or DMAC-DATA PDU.

13.4.7.12 Channel A or B operation

When the gateway sends a DMAC-SYNC PDU for a part 5 call, it shall set the "A/B channel usage" element to indicate "channel A, normal mode". When the gateway sends a DPRES-SYNC PDU on a free carrier or during a part 5 call, it shall set the "channel usage" element to 00₂.

The gateway shall not attempt to use channel A in normal mode while a frequency efficient mode call is ongoing and shall not attempt to pre-empt an ongoing frequency efficient mode call.

As indicated in clause 14, a gateway may offer a DM-REP function in which case:

- during type 1 calls (if offered), the gateway sets the "A/B channel usage" element to indicate "channel A, normal mode" and the "channel usage" element to 00₂;
- during type 2 calls (if offered), the gateway sets the "A/B channel usage" and "channel usage" elements to indicate "channel A, frequency efficient mode" or "channel B" as appropriate.

If the gateway is serving a DM-REP call when it wishes to set up a call from TMO on the DM RF carrier then it may send the free-channel presence signal until the master DM-MS sends DM-RELEASE; or, alternatively, it may try to pre-empt the call. If it was serving two type 2 calls then, having received DM-RELEASE or DM-PRE ACCEPT for one of the type 2 calls, it may send the presence signal indicating occupation on that DM channel until it has received DM-RELEASE or DM-PRE ACCEPT for the other type 2 call. It may then send the DM set-up signalling for the call from TMO, using the part 5 procedures.

13.4.7.13 Sending short data as a transaction within a circuit mode call

The procedures defined for a DM-MS in EN 300 396-3 [3], clause 8.4.7.13 shall apply also for a gateway, except that the gateway does not use the changeover mechanism to obtain the master role.

13.4.7.14 SDS and registration transaction time remaining

13.4.7.14.1 SDS time remaining

The procedures defined for a DM-MS in EN 300 396-3 [3], clause 8.4.7.14 shall apply also for a gateway sending short data as master of the DM channel.

13.4.7.14.2 Registration transaction time remaining

DM-GREGISTER CANCEL messages shall contain the "registration transaction time remaining" element indicating the gateway's current estimate of how much longer the channel will remain in registration occupation, measured from the end of the frame in which the element is sent. It shall indicate the time for the current transmission and for the expected acknowledgement messages.

13.4.7.15 Modification of slot/frame numbering by gateway

When sending call set-up signalling or during reservation periods (either during call set-up through a gateway or after a call transaction), the gateway may redefine the slot and/or frame numbering. It does so simply by setting the "slot number" and "frame number" elements appropriately in the DMAC-SYNC PDU, without a prior announcement. It shall transmit DSBs using the new slot and frame numbering in at least two slots in each of at least two frames. Repeated DSBs, sent using the frame countdown mechanism, shall use the same slot and frame timing.

When the gateway is changing the slot numbering, the DSB transmission using the new slot numbering shall include at least old slot 1 or old slot 3 in each transmission frame. It is recommended that it includes both old slot 1 and old slot 3 in each transmission frame. When necessary (e.g. for a slot numbering change of one or three slots), the DSB transmission in old slot 1 and/or old slot 3 may take precedence over TMO requirements to transmit and/or receive on the TM channel.

NOTE: This procedure for slot/frame numbering modification may be used if the gateway receives a channel change on the TMO system.

If the channel change occurs during circuit mode occupation when the gateway is transmitting traffic, then the gateway needs to terminate its traffic transmission, sending DM-TX CEASED messages. It may then send DM-SETUP messages, defining the new slot and frame numbering, and continue traffic transmission.

If the channel change occurs during circuit mode occupation when a DM-MS is transmitting traffic then the gateway needs to pre-empt the transmitting DM-MS before it can change the slot or frame numbering. The DM pre-emption procedure may take precedence over TMO requirements to transmit and/or receive on the TM channel.

13.4.7.16 Modification of channel timing by gateway

During reservation periods (either during call set-up through a gateway or after a call transaction), the gateway may modify the channel timing. It may perform this using any of the following methods:

- a) The gateway may include a "timing adjustment" element within DM-GACK messages sent during call set-up. It shall then transmit DSBs (e.g. DM-RESERVED or DM-GCONNECT messages) using the new timing reference in timeslots 1 and 3 of the next two frames.
- b) If the gateway is transmitting circuit mode traffic and wishes to modify the channel timing then it may send DM-TX CEASED messages including a "timing adjustment" element. It shall then transmit DSBs (e.g. DM-SETUP messages) using the new timing reference in timeslots 1 and 3 of the next two frames.
- c) The gateway may pre-empt a DM-MS's circuit mode transmission, including a "timing adjustment" element within the DM-PREEMPT message. When the master DM-MS accepts the pre-emption, sending DM-PRE ACCEPT messages (and DM-TX CEASED if appropriate), it announces the timing change to the other DM-MSs on the channel. The gateway shall then transmit DSBs (e.g. DM-RESERVED or call set-up messages) using the new timing reference in timeslots 1 and 3 of the next two frames.

NOTE 1: For a DM-REP/GATE, this refers to the next two slave link frames after the re-transmission of the master DM-MS's messages.

- d) The gateway may send DM-TIMING ACK messages to announce a channel timing change during reservation. It shall then transmit DSBs (e.g. DM-RESERVED messages) using the new timing reference in timeslots 1 and 3 of the next two frames.

NOTE 2: For example, procedure a) may be used if the gateway does not provide a presence signal and the channel timing chosen by a calling DM-MS is unsuitable. In this case the gateway sends the DM-GACK messages using the timing chosen by the calling DM-MS but sends all subsequent signalling using the timing announced in the DM-GACK messages.

Procedures b), c) and d) may be used if the TMO slot timing changes during a call.

The gateway may also include a "timing adjustment" element within the DM-PREEMPT message if it pre-empts a direct MS-MS call for late entry purposes. If the master DM-MS accepts the pre-emption, it announces the timing change to the other DM-MSs on the channel when it sends the DM-PRE ACCEPT messages. The gateway shall then transmit DSBs (e.g. the gateway presence signal or call set-up messages) using the new timing reference in timeslots 1 and 3 of the next two frames.

NOTE 3: Transmission of messages announcing a DM timing change may take precedence over TMO requirements to transmit and/or receive on the TM channel. Also, a DM pre-emption procedure may take precedence over TMO requirements to transmit and/or receive on the TM channel.

13.4.8 DM-REP/GATE procedures for DM re-transmission of DM signalling messages

The procedures in this clause define the DM repeater functions for a DM-REP/GATE. They apply only for a DM-REP/GATE, and only during call transactions in which a DM-MS is master of the DM channel. The DM-REP/GATE receives signalling messages and traffic sent by the master DM-MS on the master link and re-transmits that information on the slave link to the slave DM-MSs. It may also receive signalling messages from slave DM-MSs, in which case it re-transmits those messages to the master DM-MS.

These procedures define only the DM repeater functions. Other actions may be performed relating to signalling messages and traffic received from the master DM-MS – as defined in other clauses.

NOTE 1: The following re-transmission procedures apply only when practicable. In case of conflict of requirements, TMO requirements may take precedence over DM re-transmission requirements (in which case the DM-REP/GATE re-transmits as specified below, but only in those DM slots for which there is no conflict).

NOTE 2: For a type 1A DM-REP/GATE, the DM re-transmission procedures apply to reception and re-transmission on the selected DM RF carrier. Whereas, for a type 1B DM-REP/GATE, the DM re-transmission procedures apply to reception on the appropriate DM uplink RF carrier f_1 and re-transmission on the DM downlink RF carrier f_2 .

NOTE 3: The re-transmission procedures apply to all transactions in which a DM-MS is master of the DM channel. The re-transmission is needed, even for individual calls, so that other DM-MSs perceive the channel as busy and to enable pre-emption.

NOTE 4: When the DM-REP/GATE is master of the DM channel, all signalling takes place on the slave link and there is no repeater function. Throughout calls using a DM-GATE, DM-MSs receive signalling messages and traffic from other DM-MSs directly.

13.4.8.1 DM re-transmission of master DM-MS signalling messages received in a DSB

13.4.8.1.1 General procedures

When the DM-REP/GATE receives a DMAC-SYNC PDU on the master link (i.e. with "master/slave link flag" set to 1), containing "communication type" element 11_2 and its own 10-bit gateway address, it shall decide whether to re-transmit the message on the slave link as follows:

- When in idle mode, the DM-REP/GATE may accept and re-transmit a DM-SDS DATA, DM-SDS UDATA or DM-GREGISTER REQUEST message if permitted by the channel surveillance procedures described in clause 13.4.2.2.

- For a DM-SETUP or DM-RELEASE message received from a master DM-MS after the DM-REP/GATE has sent DM-GCONNECT, the DM-REP/GATE shall re-transmit the message.
- For a DM-SETUP, DM-SDS DATA or DM-SDS UDATA message following a changeover or pre-emption within the ongoing call, the DM-REP/GATE shall re-transmit the message.
- When the DM-REP/GATE is in the channel occupation state as a slave (i.e. when a DM-MS is master), it shall re-transmit all valid messages received from the master DM-MS. For example, the re-transmitted message may be DM-OCCUPIED, DM-TX CEASED, DM-RELEASE, DM-PRE ACCEPT, DM-REJECT, DM-SDS DATA, DM-SDS UDATA or DM-SDS OCCUPIED.
- For messages received at other times, the DM-REP/GATE should ignore the message.

NOTE: The DM-REP/GATE may receive a DM-PREEMPT on the master link from an idle DM-MS attempting pre-emption on the master link; this is not one of the valid messages listed above so is not re-transmitted by the DM-REP/GATE.

If the DM-REP/GATE re-transmits the message then it shall set the "master/slave link flag" to 0 and shall use the slave link's slot and frame numbering. It shall use the appropriate procedure as defined in the following clauses.

When re-transmitting DM-SETUP, DM-SDS DATA, DM-SDS UDATA and DM-GREGISTER REQUEST messages, the DM-REP/GATE shall regenerate new values for the "frame countdown", "slot number" and "frame number" elements in the DMAC-SYNC PDU as defined below. When re-transmitting DM-TX CEASED and DM-RELEASE messages for a call transaction with multi-slot interleaving, the DM-REP/GATE may regenerate new values for the "frame number" element. For other messages, the DM-REP/GATE re-transmits the "frame countdown", "slot number" and "frame number" elements without any change from the values set by the master DM-MS (unless it regenerates missing repetitions – see clause 13.4.8.3).

When re-transmitting DM-SETUP and DM-OCCUPIED messages, the DM-REP/GATE shall set the "power class" element to its own power level and shall set the "power control flag" appropriately.

All elements shall remain unchanged from the values set by the master DM-MS except for the "master/slave link flag" and the "frame countdown", "slot number", "frame number", "power class", "power control flag", "SDS time remaining" and "registration transaction time remaining" elements (and the TVP element if the DM-REP/GATE needs to re-encrypt the message as defined in clauses 13.4.8.1.6 and 13.4.8.3).

13.4.8.1.2 Re-transmission of DM-SETUP message

For a DM-SETUP message, and if the DM-REP/GATE received the master DM-MS's message in master link frame X and with "frame countdown" element set to F , then it shall re-transmit the message in all four slots (see note 1) of DN232 frames on the slave link, using the "frame countdown" element in the re-transmitted messages to indicate how many more transmission frames remain. The first required transmission frame (see note 2) on the slave link shall be slave link frame $(X+F-1) \bmod 18 + 1$; those transmissions shall contain "frame countdown" element set to DN232-1. The final transmission frame on the slave link shall be slave link frame $(X+F-2+DN232) \bmod 18 + 1$, and those transmissions shall contain "frame countdown" element set to 0. The procedure for entering traffic mode shall then be as defined in clause 13.6.3.1. See also clause 13.6.6.

NOTE 1: If there is conflict with TMO requirements then the DM-REP/GATE re-transmits the DM-SETUP message only in those DM slots for which there is no conflict.

If the DM-REP/GATE received the master DM-MS's message only in slot 3 of the frame with $F = 0$ then it need not transmit in the immediately following slot 1 on the slave link, but should then transmit in slots 2, 3 and 4 (if practicable).

NOTE 2: As defined above, the first required transmission frame on the slave link is slave link frame $(X+F-1) \bmod 18 + 1$. This is the first valid transmission frame for a type 1A DM-REP/GATE, in order to avoid collision with the master DM-MS's repeat transmissions. However, if a type 1B DM-REP/GATE's value of DN232 is less than 4 then the DM-REP/GATE may start the re-transmissions on the slave link earlier (though subject to the usual maximum of four transmission frames).

So, if a type 1B DM-REP/GATE receives the master DM-MS's message with "frame countdown" element F greater than 0, or in slot 1 of the frame with $F = 0$, then it may start the re-transmissions on the slave link V frames early (where $V+DN232$ does not exceed 4). The DM-REP/GATE uses the normal frame countdown mechanism over the $V+DN232$ transmission frames on the slave link, implemented so that the first re-transmission(s) in slave link frame $(X+F-V-1) \bmod 18 + 1$ contain "frame countdown" element set to $DN232+V-1$ and (as usual) the final re-transmissions in slave link frame $(X+F-2+DN232) \bmod 18 + 1$ contain "frame countdown" element set to 0. The DM-REP/GATE may start transmission part of the way through slave link frame $(X+F-V-1) \bmod 18 + 1$.

13.4.8.1.3 Re-transmission of DM-SDS DATA or DM-SDS UDATA message

For a DM-SDS DATA or DM-SDS UDATA message, and if the DM-REP/GATE received the master DM-MS's DMAC-SYNC PDU in master link frame X and with "frame countdown" element set to F, then it shall re-transmit the DMAC-SYNC PDU in all four slots (see note 1) of DN233 frames on the slave link, using the "frame countdown" element in the re-transmitted DMAC-SYNC PDUs to indicate how many more transmission frames remain. The first required transmission frame (see note 2) on the slave link shall be slave link frame $(X+F-1) \bmod 18 + 1$; those transmissions shall contain "frame countdown" element set to $DN233-1$. The final transmission frame on the slave link shall be slave link frame $(X+F-2+DN233) \bmod 18 + 1$, and those transmissions shall contain "frame countdown" element set to 0.

NOTE 1: If there is conflict with TMO requirements then the DM-REP/GATE generally re-transmits the DMAC-SYNC PDU only in those DM slots for which there is no conflict. However, if the DM-MS used an arbitrary channel timing when sending its DMAC-SYNC PDUs then re-transmission of the DMAC-SYNC PDU may take precedence over TMO requirements to transmit and/or receive on the TM channel.

If the DM-REP/GATE received the master DM-MS's DMAC-SYNC PDU only in slot 3 of the frame with $F = 0$ then it need not transmit in the immediately following slot 1 on the slave link, but should then transmit in slots 2, 3 and 4 (if practicable).

NOTE 2: As defined above, the first required transmission frame on the slave link is slave link frame $(X+F-1) \bmod 18 + 1$. This is the first valid transmission frame for a type 1A DM-REP/GATE, in order to avoid collision with the master DM-MS's repeat transmissions. However, if a type 1B DM-REP/GATE's value of DN233 is less than 4 then the DM-REP/GATE may start the re-transmissions on the slave link earlier (though subject to the usual maximum of four transmission frames).

So, if a type 1B DM-REP/GATE receives the master DM-MS's message with "frame countdown" element F greater than 0, or in slot 1 of the frame with $F = 0$, then it may start the re-transmissions on the slave link V frames early (where $V+DN233$ does not exceed 4). The DM-REP/GATE uses the normal frame countdown mechanism over the $V+DN233$ transmission frames on the slave link, implemented so that the first re-transmission(s) in slave link frame $(X+F-V-1) \bmod 18 + 1$ contain "frame countdown" element set to $DN233+V-1$ and (as usual) the final re-transmissions in slave link frame $(X+F-2+DN233) \bmod 18 + 1$ contain "frame countdown" element set to 0. The DM-REP/GATE may start transmission part of the way through slave link frame $(X+F-V-1) \bmod 18 + 1$.

If the DMAC-SYNC PDU contained "fragmentation flag" set to 0 then the re-transmission of the short data message is now complete.

If the DMAC-SYNC PDU contained "fragmentation flag" set to 1 then the DM-REP/GATE shall expect the master DM-MS to start sending SCH/F in slot 1 of master link frame $Y = (X+F+DN233) \bmod 18 + 1$ (if Y is in the ranges 1 to 17) or otherwise in slot 1 of master link frame 1. It shall re-transmit each SCH/F slot once, in the corresponding slot 1 on the slave link, until it receives and re-transmits the DMAC-END PDU or a DMAC-DATA PDU or fails to decode one of the SCH/F slots. The "corresponding slot 1 on the slave link" lags three slots behind slot 1 of the master link.

NOTE 3: Re-transmission of short data SCH/F slots on the slave link may take precedence over TMO requirements to transmit or receive on the TM channel. This may apply if the DM-MS used an arbitrary channel timing when sending the short data message.

13.4.8.1.4 Re-transmission of unsolicited DM-GREGISTER REQUEST

For an unsolicited DM-GREGISTER REQUEST message, the DM-REP/GATE shall use the re-transmission procedure for a non-fragmented DM-SDS DATA message (as defined in clause 13.4.8.1.3).

13.4.8.1.5 Re-transmission of other messages in a DSB when not using multi-slot regeneration

This clause applies during a short data transaction, or during a circuit mode call transaction for TCH/S, TCH/7,2 or TCH/4,8 or TCH/2,4 with $N = 1$. It applies also for TCH/4,8 or TCH/2,4 with $N = 4$ or 8 if the DM-REP/GATE is not performing traffic regeneration before re-transmission on the slave link.

Each time any message other than DM-SETUP, DM-SDS DATA, DM-SDS UDATA and DM-GREGISTER REQUEST is received from the master DM-MS in a DMAC-SYNC PDU, the DM-REP/GATE shall re-transmit the DMAC-SYNC PDU in the corresponding slot on the slave link i.e. without changing the slot and frame numbers set by the master DM-MS (see note 1). The DM-REP/GATE shall also leave the "frame countdown" element unchanged. Thus it shall change only the setting of the "master/slave link flag" (and the "power class" and "power control flag" for a DM-OCCUPIED message).

NOTE 1: When appropriate, the DM-REP/GATE is not precluded from sending the presence signal, indicating occupation, instead of re-transmitting a DM-OCCUPIED or DM-SDS OCCUPIED message on the slave link (e.g. if it needs to update the validity time for DM-MSs on the channel). This applies also in clause 13.4.8.1.6.

NOTE 2: In this clause, and in clauses 13.4.8.1.6, 13.4.8.2.1, 13.4.8.2.2 and 13.4.8.3, re-transmission of DM-PRE ACCEPT, DM-TX CEASED and DM-RELEASE messages on the slave link may take precedence over TMO requirements to transmit and/or receive on the TM channel. This may apply if there has been a TMO slot numbering or slot timing change. Also, for DM-PRE ACCEPT, it may apply if a DM-MS used an arbitrary channel timing when sending a short data message.

13.4.8.1.6 Re-transmission of other messages in a DSB during traffic transmission with multi-slot regeneration

This clause applies during a circuit mode call transaction for TCH/4,8 or TCH/2,4 with interleaving depth $N = 4$ or 8 if the DM-REP/GATE is performing traffic regeneration on the DMO side (i.e. decoding and re-encoding the traffic before re-transmission on the slave link).

When a DM-TX CEASED or DM-RELEASE message is received from the master DM-MS in a DMAC-SYNC PDU, the DM-REP/GATE should delay the re-transmission by $N - 1$ traffic frames (except in the case of a pre-emption acceptance), modifying the "frame number" element appropriately. If the message was air-interface encrypted then the DM-REP/GATE shall re-encrypt the message, modifying the TVP element appropriately.

NOTE: The delay of $N - 1$ traffic frames is in addition to the usual three-slot delay of the slave link relative to the master link.

See also note 2 in clause 13.4.8.2.2.

For other messages received from the master DM-MS in a DMAC-SYNC PDU, the DM-REP/GATE should re-transmit the DMAC-SYNC PDU in the corresponding slot on the slave link (i.e. without changing the slot and frame numbers set by the master DM-MS).

13.4.8.2 DM re-transmission of master DM-MS signalling messages received in a DNB

Refer to clause 13.6.6 for the DM-REP/GATE procedures for the re-transmission of the master DM-MS's circuit mode traffic.

13.4.8.2.1 Call transaction without multi-slot regeneration

This clause applies during a short data transaction, or during a circuit mode call transaction for TCH/S, TCH/7,2 or TCH/4,8 or TCH/2,4 with $N = 1$. It applies also for TCH/4,8 or TCH/2,4 with $N = 4$ or 8 if the DM-REP/GATE is not performing traffic regeneration before re-transmission on the slave link.

For signalling messages received from the master DM-MS in a normal burst (DNB), the DM-REP/GATE shall decode and error correct the PDU. It shall then re-encode the PDU, without changing any element values from the values set by the master DM-MS, and shall re-transmit it in the corresponding slot 1 on the slave link. For STCH, it shall use the same half slot as in the master DM-MS's transmission.

13.4.8.2.2 Call transaction with multi-slot regeneration

This clause applies during a circuit mode call transaction for TCH/4,8 or TCH/2,4 with $N = 4$ or 8 if the DM-REP/GATE is performing traffic regeneration before re-transmission on the DMO side.

When a U-plane signalling message is received from the master DM-MS (i.e. a DMAC-U-SIGNAL PDU), the DM-REP/GATE shall delay the re-transmission on the slave link by $N - 1$ traffic frames, re-encrypting the message if it was air-interface encrypted.

NOTE 1: The delay of $N - 1$ traffic frames is in addition to the usual three-slot delay of the slave link relative to the master link.

This additional delay is defined so that the DM-REP/GATE re-transmits the U-plane data stream on the slave link with the U-plane signalling in the same position as when the master DM-MS transmitted it on the master link. This position may be important if the U-plane signalling is carrying end-to-end encryption synchronization.

For a DM-PRE ACCEPT message received from the master DM-MS in a DMAC-DATA PDU, the DM-REP/GATE should re-transmit the message in the corresponding slot 1 on the slave link (i.e. without additional delay).

When a DM-TX CEASED or DM-RELEASE message is received from the master DM-MS in a DMAC-DATA PDU, the DM-REP/GATE should delay the re-transmission on the slave link by $N - 1$ traffic frames (except in the case of a pre-emption acceptance), re-encrypting the message if it was air-interface encrypted.

NOTE 2: The delay of $N - 1$ traffic frames is in addition to the usual three-slot delay of the slave link relative to the master link.

This additional delay is defined because the DM-TX CEASED or DM-RELEASE PDU terminates the traffic transmission. Therefore the DM-REP/GATE should normally ensure that it has been able to issue $N - 1$ slots containing tail bits (zeros) to the lower MAC at the end of the circuit mode data transmission before sending the transaction termination PDU. These tail bits are needed to complete the interleaving of the circuit mode data that has been received from the master DM-MS.

For other C-plane signalling messages received from the master DM-MS in a normal burst, the DM-REP/GATE may either re-transmit the message in the corresponding slot 1 on the slave link or delay the re-transmission by $N - 1$ traffic frames (re-encrypting the message if it was air-interface encrypted).

13.4.8.3 Regeneration of missing repetitions on the slave link

If the DM-REP/GATE receives a DM-TX CEASED, DM-RELEASE or DM-PRE ACCEPT message from the master DM-MS, and then fails to decode a slot 1 or a slot 3 during the master DM-MS's frame countdown for the message, the DM-REP/GATE may (optionally) regenerate a missing repetition of the message in the appropriate slot(s) on the slave link. If it does so then it shall modify the "slot number", "frame number" and "frame countdown" elements appropriately. Also, if the message was air-interface encrypted then the DM-REP/GATE shall re-encrypt the message, modifying the TVP element if sending a DSB.

If the DM-REP/GATE does not receive a DSB from the master DM-MS in slot 1 of master link frame 18 or slot 3 of master link frame 6, 12 or 18, then the DM-REP/GATE may (optionally) regenerate a DM-OCCUPIED message in the corresponding slot on the slave link, using the elements from the master DM-MS's last DM-OCCUPIED message. If it does so then it shall set the "slot number" and "frame number" elements appropriately (in addition to the "power class" and "power control flag"). Also, if the message was air-interface encrypted then the DM-REP/GATE shall re-encrypt the message, modifying the TVP element appropriately.

NOTE: If not using these options then, for messages other than DM-SETUP and DM-REGISTER REQUEST, and DM-SDS DATA and DM-SDS UDATA DSBs, the DM-REP/GATE re-transmits each PDU received from the master DM-MS only once, in the appropriate slot on the slave link.

13.4.8.4 DM re-transmission of messages received from a slave DM-MS

If the DM-REP/GATE is in channel occupation as a slave, and it receives a DMAC-SYNC PDU in a slot 3 on the slave link (i.e. with "master/slave link flag" set to 0) containing "communication type" element 11_2 and its own 10-bit gateway address, and carrying a DM-PREEMPT message, then the DM-REP/GATE should repeat that pre-emption request message on the master link except in the cases described below. It shall transmit the request once, in the appropriate slot 3 on the master link, setting the "master/slave link flag" to 1 and the "frame number" element to the master link frame number. The frame for transmission of the request on the master link shall be as defined in table 4. This results in a delay of 5 slots relative to direct MS-MS operation.

All elements other than the "master/slave link flag" and "frame number" elements shall remain unchanged from the values set by the slave DM-MS.

Table 4: Frame for DM-REP/GATE re-transmission of pre-emption request on master link

Reception frame on slave link	Transmission frame on master link
2	4
5	7
8	10
11	13
14	16
17	1

The DM-REP/GATE shall refrain from repeating a request on the master link in the following cases:

- if it has already received a DM-PRE ACCEPT, DM-TX CEASED or DM-RELEASE message from the master DM-MS; or
- if it chooses to perform addressing checks on the DM-PREEMPT message and finds that the message is not addressed to the current master DM-MS.

Also, the DM-REP/GATE may refrain from repeating a request on the master link if it is sending DM-GRELEASE or attempting pre-emption itself.

NOTE: Re-transmission of a DM-PREEMPT message on the master link may take precedence over TMO requirements to transmit or receive on the TM channel.

13.5 Layer 2 procedures for transfer of signalling messages

13.5.1 Formation of MAC PDU

The procedures defined for a DM-MS in EN 300 396-3 [3], clause 8.5.1 shall apply also for a gateway, with the following differences:

- The gateway-specific messages (e.g. DM-GCONNECT sent by the gateway, DM-GSETUP sent by DM-MSs) use a single value 11001_2 of the "message type" element. The different gateway-specific messages are then distinguished by the "gateway message subtype" element which immediately follows the "message type" element when the message type has value 11001_2 .
- References to the DMA-UNITDATA and DMV-UNITDATA primitives shall be replaced by GMA-UNITDATA and GMV-UNITDATA respectively.
- The DM-TIMING REQUEST message is not used.

The usage of PDU elements specific to gateway operation is described in clause 14. See also clause 13.5.2.

The DMAC-SYNC PDU is used by DM-MSs operating with a gateway and also by the gateway itself. The gateway may send an additional MAC PDU in a DSB. This is the gateway presence signal: the DPRES-SYNC PDU. Refer to clauses 13.4.6.2 and 14.

The same MAC PDUs may be sent within the normal burst (DNB) as for direct MS-MS operation.

13.5.2 Addressing

This clause defines addressing methods specific to the gateway. Refer also to clause 8.5.2 which describes DM-MS addressing methods for operation with a gateway.

The MAC header in a DMAC-SYNC PDU carrying a gateway-specific message contains a single 24-bit SSI: the destination address when sent by a gateway, or the source address when sent by a DM-MS. If the SSI is a true address then the MAC header also contains a 24-bit MNI.

The MAC header in a DMAC-SYNC PDU carrying other messages contains a 24-bit destination SSI and a 24-bit source SSI. If either of these is a true address then the MAC header also contains a 24-bit MNI. The source address is optional in a DMAC-DATA PDU.

13.5.2.1 Transmission of message

When the gateway layer 2 receives a GMA-UNITDATA request primitive from layer 3, the primitive contains the destination address and the destination address type as parameters.

13.5.2.1.1 Addressing in synchronization burst carrying gateway-specific message

When the gateway sends a gateway-specific message, it shall set the "source address type" element to 10_2 indicating that no source address is present.

For a DM-GACK, DM-GCONNECT, DM-GTX ACCEPT, DM-GPRE ACCEPT, DM-GREJECT, DM-GREGISTER ACCEPT or DM-GREGISTER REJECT message, the gateway shall set the destination address to the address that the requesting DM-MS has been using as its layer 2 source address – whether a true SSI or a pseudo SSI. For a DM-GRELEASE message, the gateway shall set the destination address to the address that the master DM-MS has been using as its layer 2 source address – whether true or pseudo. For a DM-GREGISTER CANCEL message, the gateway shall set the destination address to the address of the called DM-MS (as provided by layer 3).

13.5.2.1.2 Addressing in synchronization burst carrying non-gateway-specific message

In a message initiating a call set-up or short data message, and in group-addressed occupation messages, the gateway layer 2 shall set the MNI and destination SSI elements to the TETRA Subscriber Identity (TSI) of the called party – as provided by layer 3. The "destination address type" element shall be set to 00_2 . The gateway shall then include a source address as follows:

- For an intra-MNI call, if the SSI of the calling party on the TMO system is available, the gateway may set the source address element to the calling TMO SSI (with the "source address type" element set to value 00_2 to indicate that this is a true SSI). In this case the TMO SSI (with address type 00_2) shall be used throughout the call transaction as the source address in messages sent by the gateway and as the destination address by DM-MSs wishing to address the gateway.
- If the gateway cannot or does not wish to use the TMO SSI as the source address then it uses a pseudo SSI (with the "source address type" element set to value 01_2). See clause 13.5.2.1.3.

For a reservation period during a DM-MS call set-up through the gateway, the gateway shall set the destination address in reservation messages to the layer 2 address of the calling DM-MS. For a reservation period during a call set-up by the gateway, it shall set the destination address in reservation messages to the layer 2 address of the called DM-MS. For a reservation period after a call transaction, it shall set the destination address in reservation messages to the group address (for a group call) or to the DM-MS's layer 2 address (for an individual call). The gateway shall use its pseudo SSI as the source address.

A response message to a random access request shall contain the same addresses as in the invoking message but with source and destination addresses reversed.

For an individual circuit mode call, if the DM-MS has used a pseudo SSI as its source address then that pseudo SSI remains valid for the duration of the call and may be used by the gateway for addressing that DM-MS. The gateway sets its own source address as defined above (i.e. to the TMO SSI or to the gateway's pseudo SSI).

A DM-PREEMPT message shall include the current master DM-MS's layer 2 address as the destination address. This shall be the address that the master has been using as its source address – whether true or pseudo. The gateway shall use its pseudo SSI as the source address.

A response message to a short data message shall include the master DM-MS's layer 2 address (whether true or pseudo) as the destination address. The gateway shall use its pseudo SSI as the source address.

The source address element in a DM-OCCUPIED message shall be the same as in the DM-SETUP or DM-CONNECT ACK message that initiated the current traffic transmission.

13.5.2.1.3 Gateway pseudo SSI

The gateway's pseudo SSI shall be set as follows:

- 1) msb of pseudo SSI = msb of 10-bit gateway address;
etc.;
- 15th last bit of pseudo SSI = lsb of 10-bit gateway address;
- 2) the 14 least significant bits of the pseudo SSI shall then be chosen randomly.

If the gateway uses a pseudo SSI during a call then that pseudo SSI remains valid for the duration of the call and may be used as the destination address by DM-MSs wishing to address the gateway – with the "destination address type" element set to 01₂.

During a registration phase, or during a reservation period for a call set-up through the gateway, the all-zeros pseudo SSI may be used as the destination address by DM-MSs wishing to pre-empt the gateway – with the "destination address type" element set to 01₂.

13.5.2.1.4 Additional elements in synchronization burst

A DM-GATE shall set the "communication type" element to 10₂ in the DMAC-SYNC PDU whereas a DM-REP/GATE shall set the "communication type" element to 11₂ in the DMAC-SYNC PDU. In either case, the gateway shall include its 10-bit gateway address in the SCH/H block.

When sending a DMAC-SYNC PDU, the gateway shall set the "gateway generated message flag" to 1.

When a DM-REP/GATE is transmitting on the master link, it shall set the "master/slave link flag" to 1 in the DMAC-SYNC PDU and shall use the master link's slot and frame numbering. When the DM-REP/GATE is transmitting on the slave link, it shall set the "master/slave link flag" to 0 and shall use the slave link's slot and frame numbering.

13.5.2.1.5 Addressing in normal burst

The mechanisms for addressing in the DMAC-DATA PDU are similar to those in the SCH/H block of the synchronization burst except that, when a normal burst is sent, there has already been a synchronization burst to define the source address and the colour code for the scrambling of normal bursts. It is therefore optional whether the DMAC-DATA PDU includes a source address element. If it does not then the recipient implicitly assumes the layer 2 source address from the call set-up message (or short data message header).

Normal bursts are only ever sent following a synchronization burst, which defines the gateway address and information about the purpose of the normal burst. Therefore those MAC PDUs that are sent in normal bursts do not include either a "communication type" element or "gateway address" element.

For a DM-REP/GATE, the synchronization burst also defines the link type and slot numbering for that link. Then any following normal bursts for that link shall be sent only in slot 1 of frames 1 to 17 according to that link's slot and frame numbering.

13.5.2.2 Reception of message

When the gateway layer 2 receives a DMAC-SYNC PDU containing its 10-bit gateway address:

- for a gateway-specific message, or for a DM-SETUP, DM-SDS DATA or DM-SDS UDATA message, the gateway shall regard itself as addressed by the message;
- for other message types, the gateway shall regard itself as addressed by the message only if the destination address in the message is equal to:
 - its pseudo SSI or the address that it is currently using as its layer 2 address; or
 - the all-zeros pseudo SSI; or
 - when the gateway is active as a slave in channel occupation, the destination address from the set-up DSBs that initiated the transaction.

NOTE: Note particularly that, for a DM-PREEMPT, DM-PRE ACCEPT or DM-REJECT message, the gateway regards itself as addressed by the message – for passing to layer 3 – only if the message contains its 10-bit gateway address and the destination address is set to its pseudo SSI or layer 2 address (or to the all-zeros pseudo SSI). This is because, when a DM-MS is master of the channel, other DM-MSs address pre-emption requests to the master and the master addresses the response to the pre-emptor. (A DM-REP/GATE re-transmits these pre-emption and response messages on the other link if its 10-bit gateway address is included in the DMAC-SYNC PDU, as defined in clause 13.4.8, but does not pass them to layer 3).

When the gateway layer 2 receives a DMAC-DATA PDU, it shall regard itself as addressed by the message if it is active as a slave in channel occupation and the destination address in the DMAC-DATA PDU is equal to its pseudo SSI or to the destination address from the set-up DSBs that initiated the transaction.

If the gateway is addressed by the message (as defined above) then the gateway layer 2 shall process all the contents of the PDU and, for a layer 3 message, shall pass the message and any DM-SDU to layer 3 using the GMA-UNITDATA indication primitive – unless this is a repetition, as defined in clause 13.5.6. It shall indicate the source address and source address type and, when present, shall indicate the destination address on which the message was received. (If a DMAC-DATA PDU does not contain a source address element, the DM-MAC sets the source address in the GMA-UNITDATA indication primitive to the layer 2 source address from the call set-up message or short data message header – see clause 8.5.2.1.5.) The gateway layer 2 may also perform actions itself, based on the message type and message-dependent elements.

If the gateway is not addressed by the message then the gateway layer 2 may use the elements visible at layer 2 (e.g. to update its channel state model) but shall not pass the message to layer 3.

13.5.2.3 Usage of MNI

The MNI element is conditional in both the DMAC-SYNC and DMAC-DATA PDU. It shall be included if either the source or destination address is a true address i.e. if the "source address type" element = 00₂ and/or the "destination address type" element = 00₂.

13.5.3 Use of air interface encryption

The procedures defined for a DM-MS in EN 300 396-3 [3], clause 8.5.3 shall apply also for a gateway, except that the reference to the DMD-SAP shall be replaced by GMD-SAP.

NOTE: In order to function correctly, the gateway needs to be able to decrypt signalling messages for calls using that gateway. Therefore the gateway needs to hold the appropriate air interface encryption information.

When using air interface encryption, the encryption key numbers for all DM-MSs using a particular gateway need to be co-ordinated so that the encryption key numbering is unique for that gateway.

13.5.4 Fragmentation and reconstruction

13.5.4.1 Fragmentation by a gateway

The procedures defined for a DM-MS in EN 300 396-3 [3], clause 8.5.4.1 shall apply also for a gateway layer 2 sending a message received from layer 3, except that references to the DMA-REPORT indication shall be replaced by GMA-REPORT. (So, when sending a fragmented message using method 1), the gateway sends the DMAC-SYNC PDU the appropriate number of times and then sends the first DMAC-FRAG PDU (or DMAC-END PDU) in slot 1 of the first frame in the range 1 to 17 following the frame with "frame countdown" element set to 00₂. The gateway then continues to follow the fragmentation procedure defined in EN 300 396-3 [3], clause 8.5.4.1).

NOTE: When sending a fragmented DM-SDS UDATA or DM-SDS DATA message received from layer 3, a DM-REP/GATE uses the slave link. References to slot and frame numbers therefore refer to the slot and frame numbering on the slave link.

When sending a fragmented DM-SDS ACK message, a DM-REP/GATE uses the master link. References to slot and frame numbers therefore refer to the slot and frame numbering on the master link.

13.5.4.2 Reconstruction by a gateway

NOTE: Clause 13.5.2.2 defines when the layer 2 in a gateway may deliver a received DM-SDU to layer 3.

13.5.4.2.1 Reconstruction by a DM-GATE

The procedures defined for a DM-MS in EN 300 396-3 [3], clause 8.5.4.2 shall apply also for a DM-GATE, with the following differences:

- i) References to the DMA-UNITDATA indication shall be replaced by GMA-UNITDATA.
- ii) In case 2), and if the partially received message was a DM-GSETUP, the gateway layer 2 shall deliver the message type to layer 3 but shall indicate that the DM-SDU was not fully received. Failure to decrypt the DM-SDU should not be considered a failure to receive the DM-SDU. (As usual, the equivalent procedure applies for DM-SDS DATA and DM-SDS ACK).

So, if a DMAC-SYNC PDU indicating start of fragmentation was received in frame X and contained "frame countdown" element F, the DM-GATE looks for the first DMAC-FRAG/DMAC-END in slot 1 of frame $Y = (X+F) \bmod 18 + 1$ (if Y is in the range 1 to 17) or otherwise in slot 1 of frame 1. The DM-GATE then continues to follow the reconstruction procedure defined in EN 300 396-3 [3], clause 8.5.4.2.

13.5.4.2.2 Reconstruction of master link message by DM-REP/GATE

The procedures defined for a DM-MS in EN 300 396-3 [3], clause 8.5.4.2 shall apply also for a DM-REP/GATE receiving a message on the master link, with the following differences:

- i) References to the DMA-UNITDATA indication shall be replaced by GMA-UNITDATA.
- ii) When receiving a fragmented DM-SDS DATA or DM-SDS UDATA message, where the DMAC-SYNC PDU indicating start of fragmentation was received in frame X of the master link and contained "frame countdown" element F, the DM-REP/GATE shall look for the first DMAC-FRAG/DMAC-END in slot 1 of master link frame $Y = (X+F+DN233) \bmod 18 + 1$ (if Y is in the range 1 to 17) or otherwise in slot 1 of master link frame 1. The DM-REP/GATE shall then continue to follow the reconstruction procedure defined in EN 300 396-3 [3], clause 8.5.4.2.
- iii) When receiving a fragmented DM-SDS DATA or DM-SDS UDATA message: on receipt of a DMAC-END PDU, the DM-REP/GATE shall check that it has received the number of SCH/F slots indicated by the "number of SCH/F slots" element S from the DMAC-SYNC PDU i.e. that it received $S - 1$ DMAC-FRAG PDUs before receiving the DMAC-END PDU. If the received number of SCH/F slots matches the "number of SCH/F slots" element then the DM-REP/GATE layer 2 shall deliver the reconstructed DM-SDU to layer 3 using a GMA-UNITDATA indication primitive. If the received number of SCH/F slots does not match the "number of SCH/F slots" element then the DM-REP/GATE layer 2 shall discard the message (without an indication to layer 3).

NOTE: DM-SDS DATA and DM-SDS UDATA are the only fragmented messages that the DM-REP/GATE expects to receive on the master link. This clause defines the reconstruction procedure for delivering the message to layer 3. The equivalent DM-REP/GATE procedure for DM re-transmission of a DM-MS's short data message on the slave link is defined in clause 13.4.8.1.3.

13.5.4.2.3 Reconstruction of slave link message by DM-REP/GATE

The procedures defined for a DM-MS in EN 300 396-3 [3], clause 8.5.4.2 shall apply also for a DM-REP/GATE receiving a message on the slave link, with the following differences:

- i) References to the DMA-UNITDATA indication shall be replaced by GMA-UNITDATA.
- ii) In case 2), and if the partially received message was a DM-GSETUP, the gateway layer 2 shall deliver the message type to layer 3 but shall indicate that the DM-SDU was not fully received. (As usual, the equivalent rule applies for DM-SDS ACK).

So, if a DMAC-SYNC PDU indicating start of fragmentation was received in frame X of the slave link and contained "frame countdown" element F, the DM-REP/GATE looks for the first DMAC-FRAG/DMAC-END in slot 1 of slave link frame $Y = (X+F) \bmod 18 + 1$ (if Y is in the range 1 to 17) or otherwise in slot 1 of slave link frame 1. The DM-REP/GATE then continues to follow the reconstruction procedure defined in EN 300 396-3 [3], clause 8.5.4.2.

NOTE: DM-GSETUP and DM-SDS ACK are the only fragmented messages that the DM-REP/GATE expects to receive on the slave link. Therefore, in this edition of the present document, the DM-REP/GATE should not receive DMAC-FRAG on the slave link.

13.5.5 Fill bit addition and deletion

The procedures defined for a DM-MS in EN 300 396-3 [3], clause 8.5.5 shall apply also for a gateway, except that references to the DMA-SAP shall be replaced by GMA-SAP.

13.5.6 Transmission and reception of messages by layer 2 unacknowledged service

When the gateway layer 2 receives a GMA-UNITDATA request primitive from layer 3, it shall use its current state and the message type parameter to decide how to send the message:

- a) For the initiation of a new call, or for a retransmission of DM-SETUP PRES after set-up failure or a non-immediate retransmission of DM-SDS DATA, the gateway layer 2 shall check whether the channel is free (as defined in clause 13.4.2) before transmitting the DM-SETUP, DM-SETUP PRES, DM-SDS DATA or DM-SDS UDATA message as master.
- b) For a call set-up after pre-emption, the gateway layer 2 shall transmit the DM-SETUP, DM-SETUP PRES, DM-SDS DATA or DM-SDS UDATA message as master. If appropriate, it times its transmissions using the "frame countdown" element from the received DM-PRE ACCEPT message.
- c) If the gateway is already a master, the gateway layer 2 may transmit the message and shall use the appropriate burst(s). For example, this may apply to:
 - DM-SETUP, DM-SETUP PRES, DM-SDS DATA, DM-SDS UDATA, DM-OCCUPIED, DM-TX CEASED, DM-RELEASE, DM-TX ACCEPT, DM-PRE ACCEPT, DM-REJECT and DM-INFO;
 - DM-GACK, DM-GCONNECT, DM-GTX ACCEPT, DM-GPRE ACCEPT and DM-GREJECT;
 - DM-GREGISTER ACCEPT and DM-GREGISTER REJECT during a registration phase.
- d) If the message is DM-CONNECT ACK, the gateway layer 2 shall transmit the message. If appropriate, it times the transmission using the "frame countdown" element from the DM-CONNECT.
- e) If the message is DM-SDS ACK or DM-REJECT sent in response to DM-SDS DATA, or DM-GREGISTER ACCEPT or DM-GREGISTER REJECT outside a registration phase, the gateway layer 2 shall time its transmission using the "frame countdown" element from the invoking message.

- f) For a DM-GREGISTER CANCEL message, the gateway layer 2 shall check whether the channel is free (as defined in clause 13.4.2) before transmitting the message as master.
- g) If the message is DM-PREEMPT or DM-GRELEASE, the gateway layer 2 shall use the gateway access protocol for sending the message.

In the gateway access protocol, the gateway layer 2 sends retries until a response is received or the access attempt fails. The gateway access protocol is described in clause 13.5.7.3.

For the other message types, the service provided by layer 2 to layer 3 is an unacknowledged service. Layer 2 transmits the message the appropriate number of times and shall then report to layer 3 when the message has been sent (GMA-REPORT indication primitive). The acknowledgement protocol (if any) and any resulting retransmission is under the control of layer 3. If layer 2 is unable to send the message (e.g. in case a) above if the channel becomes busy) then it shall report the failure to layer 3.

This clause describes the tools for the layer 2 unacknowledged service.

NOTE: Cases a) and f) are the only cases when the gateway layer 2 is required to check whether the channel is free before transmitting a message as a result of a GMA-UNITDATA request primitive from layer 3. (Checking may be required before the gateway layer 2 sends the presence signal, as specified in other clauses).

13.5.6.1 Transmission of message

The procedures defined for a DM-MS in EN 300 396-3 [3], clause 8.5.6.1 shall apply also for a gateway, except that references to the DMA-UNITDATA and DMA-REPORT primitives shall be replaced by GMA-UNITDATA and GMA-REPORT.

NOTE 1: The procedures defined for sending DM-PRE ACCEPT in a DNB apply also to DM-GPRE ACCEPT.

NOTE 2: DM-REP/GATE transmissions to a master DM-MS use the master link slot and frame numbering, whereas DM-REP/GATE transmissions to slave DM-MSs use the slave link slot and frame numbering.

NOTE 3: A DM-GATE or type 1A DM-REP/GATE transmits on the selected DM RF carrier. A type 1B DM-REP/GATE transmits on the DM downlink RF carrier f_2 .

13.5.6.2 Reception of message

NOTE 1: A DM-GATE or type 1A DM-REP/GATE receives on the selected DM RF carrier. A type 1B DM-REP/GATE receives on the DM uplink RF carrier f_1 .

The recipient gateway layer 2 may use the "frame countdown" element F in received messages in several ways:

a) **Suppression of duplicates:**

The procedures defined for a DM-MS in EN 300 396-3 [3], clause 8.5.6.2 a) shall apply also for a gateway, except that the reference to the DMA-UNITDATA primitive shall be replaced by GMA-UNITDATA.

b) **Delaying switch into traffic mode:**

When the gateway receives a message indicating that it should change into traffic mode (i.e. DM-SETUP), it shall use the timings defined in clause 13.6.3.1.

c) **Timing of set-up signalling after pre-emption:**

When a gateway receives a DM-PRE ACCEPT message from a master DM-MS (received in frame X), it shall use the "frame countdown" element F in the master's message to deduce when set-up DSBs can be sent; the transmission of set-up DSBs (or DM-RESERVED messages) shall not start until at least frame $(X+F) \bmod 18 + 1$. For a DM-REP/GATE, these frame numbers refer to reception in master link frame X and then to transmission in slave link frame $(X+F) \bmod 18 + 1$.

d) Timing of immediate SDS retransmission:

The procedures defined for a DM-MS in EN 300 396-3 [3], clause 8.5.6.2 d) shall apply also for a gateway. For a DM-REP/GATE, the timings given refer to reception of the DM-SDS ACK on the slave link, and then transmission of the DM-SDS DATA DSBs on the slave link.

e) Timing of response to non-fragmented message from master DM-MS:

The procedures defined for a DM-MS in EN 300 396-3 [3], clause 8.5.6.2 e) shall apply also for a DM-GATE except that DN210 shall be replaced by DN270.

When a DM-REP/GATE sends a response to a non-fragmented message from a master DM-MS, it shall wait until after it has re-transmitted the master DM-MS's message in DN233 frames on the slave link. So, if the master DM-MS's message was received in master link frame X and contained "frame countdown" element F, the DM-REP/GATE's response DSB shall be sent in master link frame $(X+F+DN233) \bmod 18 + 1$, in both slot 1 and slot 3 of that frame (or only in slot 3). The response DSB may be sent in up to DN270 frames, with the "frame countdown" element set to the appropriate values. If the response is fragmented (i.e. DMAC-SYNC + DMAC-END) then the frame countdown refers only to the DMAC-SYNC PDU; the DMAC-END shall then be sent in a DNB, without repetition, in slot 1 of the next master link frame in the range 1 to 17.

NOTE 2: The gateway should transmit the response DSB in both slot 1 and slot 3 of the DN270 – 1 frames after the first transmission frame.

NOTE 3: These timings apply to the transmission of a DM-SDS ACK or DM REJECT message in response to a non-fragmented DM-SDS DATA message. They also apply to the transmission of the response to an unsolicited registration request.

f) Timing of response to fragmented message from master DM-MS:

The procedures defined for a DM-MS in EN 300 396-3 [3], clause 8.5.6.2 f) shall apply also for a DM-GATE except that DN210 shall be replaced by DN270.

When a DM-REP/GATE sends a response to a fragmented message from a master DM-MS, it shall wait until after it has re-transmitted the master DM-MS's message (DSBs and following fragments) on the slave link. So, if the DM-REP/GATE receives the master DM-MS's DMAC-END PDU in slot 1 of master link frame X, re-transmitting it in slot 1 of slave link frame X, then the DM-REP/GATE's response DSB shall be sent in master link frame $X + 1$, in both slot 1 and slot 3 of that frame (or only in slot 3). The response DSB may be sent in up to DN270 frames, with the "frame countdown" element set to the appropriate values. If the response is fragmented (i.e. DMAC-SYNC + DMAC-END) then the frame countdown refers only to the DMAC-SYNC PDU; the DMAC-END shall then be sent in a DNB, without repetition, in slot 1 of the next master link frame in the range 1 to 17.

NOTE 4: The gateway should transmit the response DSB in both slot 1 and slot 3 of the DN270 – 1 frames after the first transmission frame.

If the DM-REP/GATE did not receive the DMAC-END PDU terminating a fragmented DM-SDS DATA message then the DM-REP/GATE shall use the "number of SCH/F slots" element from the DMAC-SYNC PDU to deduce when the DMAC-END was sent. It shall transmit the response DM-SDS ACK in both slot 1 and slot 3 of the next master link frame (or only in slot 3), and in up to DN270 – 1 further frames. However, during the time since the reconstruction failure, the DM-REP/GATE shall monitor slot 1 of each master link frame looking for DSBs (and, as usual, it shall monitor slot 3 except when transmitting or linearizing). If, during that time, it receives a DM-PRE ACCEPT message then it shall refrain from transmitting the DM-SDS ACK.

g) Timing of response to non-fragmented message from slave DM-MS:

When the gateway sends a response to a non-fragmented message from a slave DM-MS, it shall use the "frame countdown" element F in the slave's message (received in frame X) to deduce when the response (or other signalling) can be sent without colliding with the slave's repetitions; the gateway's transmission shall not start until at least frame $(X+F) \bmod 18 + 1$. (For a DM-REP/GATE, these frame numbers both refer to the slave link).

NOTE 5: These timings apply when the gateway sends a response to DM-GSETUP, and may apply for a response to DM-GTX REQUEST (if the DM-GTX REQUEST was sent after pre-emption of another DM-MS). They also apply to transmission of DM-CONNECT ACK after receiving DM-CONNECT, or if the gateway sends DM-RELEASE after receiving either DM-CONNECT or DM-DISCONNECT.

h) Timing of response to fragmented DM-GSETUP message from slave DM-MS:

For a fragmented DM-GSETUP message, the "frame countdown" element F refers only to the DMAC-SYNC. If the gateway supports reconstruction, and if it receives a DMAC-SYNC PDU in frame X indicating start of fragmentation, then it shall look for the final fragment in slot 1 of frame $Y = (X+F) \bmod 18 + 1$ (if Y is in the range 1 to 17) or otherwise in slot 1 of frame 1. The gateway's response message (or other signalling) shall not be sent until at least slot 3 of the frame that contained the DMAC-END. (For a DM-REP/GATE, these frame numbers refer to the slave link).

Points e) and f) define when the first transmission of a response message must be sent. According to the protocol description, it is assumed that, when the gateway has received a DM-SDS DATA message addressed to itself, and if layer 3 does not immediately return a response DM-SDS ACK, then layer 2 shall issue a GMC-REPORT indication primitive as a prompt to layer 3 in time to allow transmission in the correct slot(s).

13.5.7 Random access protocol during occupation and reservation periods

13.5.7.1 Introduction

During both the occupation and reservation periods, a DM-MS that wishes to transmit traffic or short data must first request and be granted permission by the current master before performing a set-up procedure and becoming master of the channel itself. It requests permission using the random access protocol described in clause 8.5.7.3.

The current master may be either a DM-MS or the gateway during occupation, but is always the gateway during channel reservation. The procedures for a master DM-MS responding to a random access request are described in clause 8.5.7.2 whereas the procedures for a master gateway responding to a random access request are described in clause 13.5.7.2.

NOTE 1: When a DM-MS is master of the channel, it is the responsibility of that master DM-MS to decide whether to accept a slave DM-MS's random access request and then to send the response. However, for a successful pre-emption for a circuit mode transaction within the ongoing call, the requesting DM-MS then needs to send DM-GTX REQUEST to the gateway; see clause 6.2.4.2.

When a DM-MS is master of the channel, the gateway may send the DM-PREEMPT message if it wishes to pre-empt the master DM-MS's transmission; or it may send the DM-GRELEASE message if it wishes to indicate that it can no longer support the ongoing call. It sends these messages using the gateway access procedures described in clause 13.5.7.3.

NOTE 2: The procedures described in clause 13.5.7.3 apply only when the gateway is active in the call. If an idle gateway wishes to pre-empt a DM-MS then it uses the normal DM-MS random access procedures described in clause 8.5.7.3 of the part of EN 300 396 appropriate to the ongoing call (first synchronizing to the master DM-MS in the normal manner for a slave DM-MS).

13.5.7.2 Procedures for master gateway

NOTE: A master DM-REP/GATE receives and responds to random access messages on the slave link. Therefore, for a DM-REP/GATE, references to slot and frame numbers throughout clause 13.5.7.2 refer to the slot and frame numbering on the slave link.

13.5.7.2.1 Indicating frames available for requests

When the gateway transmits DM-GACK and DM-RESERVED messages during a reservation period for call set-up through the gateway, it may set the "requests flag" to 1 to indicate that pre-emption requests may be sent (though it shall set the "changeover requests flag" to 0). If pre-emption requests are invited then the gateway shall also set the "requests bitmap" element to indicate whether pre-emption requests may be sent in slot 3 of frames 1, 4, 7, 9, 10, 13, 15 and 16 during the reservation period (in addition to slot 3 of frames 2, 5, 8, 11, 14 and 17).

When the gateway transmits DM-SETUP, DM-CONNECT ACK and DM-OCCUPIED messages, except when it has received and is processing an emergency pre-emption request to continue the existing call, it shall set the "pre-emption flag" to indicate that slot 3 of frames 2, 5, 8, 11, 14 and 17 is available for pre-emption requests during the occupation period. When the gateway has received an emergency pre-emption request to continue the existing call, then while it is still in occupation it may set the "pre-emption flag" in DM-OCCUPIED messages in the same way.

NOTE: This requirement may be relaxed for some other types of call in future editions of the present document.

When the gateway transmits DM-TX CEASED messages, and DM-RESERVED messages during the reservation period after a call transaction, it shall set the "requests flag" and "changeover requests flag" to indicate whether random access requests may be sent. If random access requests are invited then the gateway shall also set the "requests bitmap" element to indicate whether random access requests may be sent in slot 3 of frames 1, 4, 7, 9, 10, 13, 15 and 16 during the reservation period (in addition to slot 3 of frames 2, 5, 8, 11, 14 and 17).

The gateway shall set the "timing flag" to 0 to indicate that timing change requests are not invited.

13.5.7.2.2 Monitoring frames available for requests

During channel reservation for call set-up through the gateway, if requests are invited, the gateway shall monitor slot 3 of frames 2, 5, 8, 11, 14 and 17, and also slot 3 of the frames indicated in the "requests bitmap", looking for DM-PREEMPT messages addressed to itself.

During occupation for a circuit mode call, the gateway shall monitor slot 3 of frames 2, 5, 8, 11, 14 and 17 for pre-emption requests addressed to itself.

During channel reservation after a call transaction, if requests are invited, the gateway shall monitor slot 3 of frames 2, 5, 8, 11, 14 and 17, and also slot 3 of the frames indicated in the "requests bitmap", looking for pre-emption or changeover requests addressed to itself.

When sending SCH/F for a fragmented DM-SDS UDATA or DM-SDS DATA message, the gateway shall monitor slot 3 of frames 2, 5, 8, 11, 14 and 17 for pre-emption requests addressed to itself.

NOTE 1: If the protocol requires the gateway to transmit in any of the monitoring slots specified in this clause, the transmission takes precedence over the monitoring requirement.

NOTE 2: In the above procedures, a pre-emption request may be either a DM-PREEMPT or DM-GPREEMPT message; a changeover request may be either a DM-TX REQUEST or DM-GTX REQUEST message.

13.5.7.2.3 Response to pre-emption or changeover request

On receipt of a pre-emption or changeover request addressed to itself, the gateway layer 2 shall deliver the message to layer 3 in a GMA-UNITDATA indication primitive. Layer 3 will then issue a response to the message in a GMA-UNITDATA request primitive. For a changeover request, the gateway layer 2 shall send the response in the DSB. For a pre-emption request, and when sending the response in slot 1 of a frame in the range 1 to 17, the gateway layer 2 shall use the DNB during circuit mode occupation, or the DSB during reservation or short data occupation.

- a) If the response is a DM-GACK and if layer 3 issues a final response before layer 2 has sent the DM-GACK then layer 2 may discard the DM-GACK and send the final response instead (using procedure b) or c) below). Otherwise layer 2 shall send the DM-GACK as follows:
 - If the response is a DM-GACK sent during reservation or short data occupation then layer 2 shall send the message in slot 1 in at least one frame. It may send the DM-GACK message also in each corresponding slot 3 using a DSB.
 - If the response is a DM-GACK sent during circuit mode occupation then layer 2 may send the message in slot 1 in at least one frame (in which case it may send the message also in each corresponding slot 3 using a DSB). Alternatively, it may send the DM-GACK message using a DSB in one or more slot 3's, in frames 1, 4, 7, 9, 10, 13, 15 or 16.

The gateway should send the first transmission of the response within a time of 2 frame durations following receipt of the request for circuit mode occupation or channel reservation, or within a time of 6 frame durations for short data occupation.

- b) If the gateway accepts the request then it shall send the response (DM-PRE ACCEPT, DM-GPRE ACCEPT, DM-TX ACCEPT or DM-GTX ACCEPT) several times, for reliability, using the "frame countdown" mechanism. If the gateway has not sent a DM-GACK, it should send the first response within a time of 2 frame durations following receipt of the request for circuit mode occupation or channel reservation, or within a time of 6 frame durations for short data occupation.

The gateway shall send the acceptance response in slot 1 in at least two frames:

- If sending the response using the DNB in slot 1 (i.e. for pre-emption acceptance during circuit mode occupation), the gateway shall send the DM-PRE ACCEPT or DM-GPRE ACCEPT in the same slot as the DM-TX CEASED or DM-RELEASE message, one in each of two stolen half slots. The gateway shall also send the DM-PRE ACCEPT or DM-GPRE ACCEPT (using the DSB) in each corresponding slot 3 if this is not a linearization frame. If the message transmission crosses frame 18 then the gateway shall also send the DM-PRE ACCEPT or DM-GPRE ACCEPT (using the DSB) in slot 1 and/or slot 3 of that frame.
- If sending the response using the DSB in slot 1 (for either pre-emption or changeover), the gateway shall repeat the response in each corresponding slot 3 if this is not a linearization frame. Optionally, the gateway may send the response also in the preceding slot 3. (This may apply if the response is first ready to be sent in a slot 3).

NOTE 1: Transmission of DM-PRE ACCEPT, DM-GPRE ACCEPT, DM-TX ACCEPT or DM-GTX ACCEPT takes precedence over the transmission of channel occupation or reservation messages in frames 6, 12 and 18.

The gateway may also send the acceptance response using the DSB in slots 2 and/or 4 of each of the transmission frames (e.g. if changing the slot numbering).

A pre-emption request contains a "perceived channel state" element. If the requesting DM-MS indicated circuit mode occupation when the gateway is in reservation or short data occupation, or if the requesting DM-MS indicated reservation or short data occupation when the gateway is in circuit mode occupation, then the gateway shall send the DM-PRE ACCEPT or DM-GPRE ACCEPT in four frames.

If accepting a pre-emption request during short data occupation:

- For a DM-SDS UDATA message, the gateway may finish its current message transmission if it can do so within the 6 frame durations constraint. Otherwise it shall send the Null PDU once on SCH/F to terminate its current transmission and then send the DM-PRE ACCEPT or DM-GPRE ACCEPT using DSBs.
- For a DM-SDS DATA message, and if the gateway still has more than DN272 SCH/F slots to send to complete its message transmission, it shall send the Null PDU once on SCH/F to terminate its current transmission and then send the DM-PRE ACCEPT or DM-GPRE ACCEPT using DSBs. Otherwise the gateway may complete the current message transmission; then it shall not send the DM-PRE ACCEPT or DM-GPRE ACCEPT until it has received a DM-SDS ACK or DM-REJECT message from the short data recipient plus any repetitions within the recipient's frame countdown (and has monitored for a final fragment if appropriate) or until after the DT270 frame durations following the slot in which it transmitted the DMAC-END. In the latter case the gateway should send a first transmission of the DM-PRE ACCEPT or DM-GPRE ACCEPT in slot 3 of the DT270th frame following the frame that contained the DMAC-END.

After accepting a new call pre-emption, the gateway shall enter idle mode. After accepting a pre-emption within the ongoing call or a changeover request, the gateway expects the requesting DM-MS to send DSBs as master.

NOTE 2: For a pre-emption within the ongoing call or a changeover request, layer 3 instructs layer 2 on the appropriate action if DSBs are not received from the DM-MS. For example, layer 3 may issue a GMC-CONFIGURE request primitive indicating a return to channel reservation or it may send DM-SETUP (see clause 9).

- c) If the gateway rejects the request then it may send the DM-REJECT or DM-GREJECT in a slot 1. It need not repeat the message. Alternatively, during circuit mode occupation, the gateway may send the DM-REJECT or DM-GREJECT using a DSB in one or more slot 3's, in frames 1, 4, 7, 9, 10, 13, 15 or 16.

The following procedures shall apply if the gateway receives a pre-emption or changeover request near the end of reservation:

- In the case of acceptance of the pre-emption or changeover request, the gateway may send the response provided that the transmission of the response starts before the end of the announced reservation period. If the transmission of the response starts in the final frame of the announced reservation period, the gateway shall transmit the response in both slot 1 and slot 3 of that frame. (A DM-GACK may increase the reservation time remaining.)

The gateway shall then continue the transmission of the response using the frame countdown mechanism in the normal way.

- In the case of rejection of the pre-emption or changeover request, transmission of the response is only permitted during the reservation period. If the transmission could not be completed within the reservation period, the gateway shall not send the DM-REJECT message.

13.5.7.3 Procedures for requesting slave gateway

NOTE: A requesting slave DM-REP/GATE sends its message and expects to receive a response on the master link. Therefore, for a DM-REP/GATE, references to slot and frame numbers throughout clause 13.5.7.3 refer to the slot and frame numbering on the master link.

13.5.7.3.1 Transmission of message by requesting slave gateway

When a slave gateway wishes to send a DM-PREEMPT or DM-GRELEASE message to the master DM-MS during circuit mode occupation, it shall transmit the message in the following slots:

- A DM-GATE shall transmit its message in slot 3 of frames 1, 7 and 13. Additionally, at the start of the transmission procedure, if a slot 3 of frame 2, 5, 8, 11, 14 or 17 occurs before a slot 3 of frame 1, 7 or 13, the DM-GATE may send a first transmission of its message in that pre-emption frame.
- A DM-REP/GATE shall transmit its message in slot 3 of master link frames 1, 7 and 13 (unless it is re-transmitting a higher priority message received from a DM-MS). The DM-REP/GATE may also transmit its message in slot 3 of master link frames 4, 10 and 16 (unless it is re-transmitting a higher priority message received from a DM-MS).

When a slave gateway wishes to send a DM-PREEMPT or DM-GRELEASE message to the master DM-MS during short data occupation, it shall transmit the message in the same slots as for circuit mode occupation, but restricted to those frames in which the master DM-MS intends to send SCH/F in slot 1.

NOTE: The SCH/F frames were indicated by the combination of the "frame countdown" and "number of SCH/F slots" elements in the DMAC-SYNC PDU that contained the DM-SDS DATA or DM-SDS UDATA header.

13.5.7.3.2 Looking for response

After transmitting a DM-PREEMPT or DM-GRELEASE message, the gateway shall monitor slots 1 and 3 of the following frames (except those slots in which it is transmitting or linearizing) to determine the result of its message:

- for a DM-PREEMPT message, valid responses are DM-PRE ACCEPT or DM-REJECT with the same layer 2 addresses as in the request but with source and destination addresses reversed;
- for a DM-GRELEASE message, the gateway looks for a DM-RELEASE message for the call.

On receipt of a response, the gateway layer 2 shall report the success of the transmission procedure to layer 3 using the GMA-REPORT indication primitive. It shall also deliver the received message to layer 3 using the GMA-UNITDATA indication primitive.

13.5.7.3.3 Abandoning transmission attempt

The gateway may continue transmission of its DM-PREEMPT or DM-GRELEASE message (as defined in clause 13.5.7.3.1) until it receives a response from the master DM-MS or one of the following occurs:

- a) a time DT273 has elapsed since layer 3 issued the GMA-UNITDATA request primitive; or
- b) the gateway receives a message indicating the end of channel occupation; or
- c) the gateway's channel surveillance procedures indicate the end of channel occupation.

In cases a), b) and c), the failure of the transmission procedure should be reported to layer 3 using the GMA-REPORT indication primitive.

13.5.8 Procedures in registration phase

NOTE: During a registration phase a DM-REP/GATE transmits and receives messages on the slave link. Therefore, for a DM-REP/GATE, references to slot and frame numbers throughout clause 13.5.8 refer to the slot and frame numbering on the slave link.

13.5.8.1 Start of registration phase

On receipt of a GMC-CONFIGURE request primitive from layer 3 requesting that a registration phase be initiated, the gateway shall carry out the surveillance procedures defined in clause 13.4.2.2.5.

When the channel is perceived as being free, the gateway shall announce the registration phase by generating a presence signal containing the appropriate parameters and shall start the "registration phase time remaining" timer.

It shall send the presence signal using a DSB in timeslots 1 and 3 of frames FN and FN+1 up to a maximum of FN+3, where FN is the current value of the gateway's DM frame counter. It shall also send the message in timeslots 2 and 4 in each of the signalling frames when practicable (i.e. when it does not conflict with TMO requirements). The number of frames in which the message is sent shall be indicated by the frame countdown element.

13.5.8.2 Receiving registration requests

During a registration phase the gateway shall monitor timeslot 3 for a DSB containing registration or pre-emption request signalling. The gateway shall conduct this monitoring in all frames except frames 3, 6, 12 and 18, and any frames in which it is transmitting DM-PRE ACCEPT.

On receipt of a DM-GREGISTER REQUEST or a DM-PREEMPT message the gateway layer 2 shall deliver the received message to layer 3 using the GMA-UNITDATA indication primitive.

13.5.8.3 Sending response

On receipt of a GMA-UNITDATA request primitive from layer 3 containing a DM-GREGISTER ACCEPT or DM-GREGISTER REJECT message, the gateway shall send the message using a DSB in timeslot 1 of at least one frame.

On receipt of a GMA-UNITDATA request primitive from layer 3 containing a DM-PRE ACCEPT message, the gateway shall transmit the message using a DSB in timeslot 1 of at least two frames:

- If element "air interface encryption state" is not set to 01₂ (not security class DM-2-C), it shall send the message using a DSB also in each corresponding timeslot 3 (except for linearization frames), and may send the message in timeslots 2 and 4.
- If element "air interface encryption is set to 01₂ (security class DM-2-C), the gateway should transmit the message using a DSB in timeslot 1 of four frames. In each corresponding timeslot 3 (except for linearization frames), it should send a free channel presence signal DSB with "registration phase terminated flag" set to 1, so that DM-MS that do not support DM-2-C or do not have the same keys can be aware that the registration phase has ended. It may also send the free channel presence signal in timeslots 2 and 4.

The number of frames in which the message or messages is / are sent shall be indicated by the frame countdown element in each DSB.

On receipt of a GMA-UNITDATA request primitive from layer 3 containing a DM-REJECT message, the gateway shall transmit the message in a timeslot 1. It need not repeat the message.

13.5.8.4 Maintenance of registration phase

During the registration phase the gateway shall send the presence signal using a DSB in timeslots 1 and 3 of frames 6, 12 and 18.

It may also send the presence signal in timeslots 2 and 4 when appropriate e.g. if it is changing the slot numbering.

NOTE 1: When changing the slot numbering, transmission of the presence signal in old timeslot 1 and/or old timeslot 3 may take precedence over TMO requirements to transmit and/or receive on the TM channel.

The gateway presence signal shall contain an element ("registration phase time remaining") indicating how much longer the DM channel is anticipated to remain in the registration phase.

NOTE 2: The gateway may extend the registration phase by increasing the value of the "registration phase time remaining" element.

The gateway presence signal shall contain an element ("registration access parameter") indicating the randomization for requesting DM-MSs. The gateway may vary the "registration access parameter" in the presence signal as appropriate in order to control collisions.

13.5.8.5 Termination of registration phase

The registration phase shall terminate when a GMC-CONFIGURE request primitive is received from layer 3 requesting that the registration phase is terminated or the "registration phase time remaining" timer has expired. The final presence signal messages sent on termination of the registration phase shall indicate the end of the registration phase by setting the "registration phase time remaining" element to 0000₂. The final presence signal may be sent in multiple frames, using the frame countdown mechanism to indicate the number of frames in which the message is sent. If the gateway wants a premature termination to have immediate effect, then the gateway shall instead send a free channel presence signal with "registration phase time remaining" element set to 0000₂ and "registration phase terminated flag" set to 1 but otherwise in accordance with clause 13.4.6.2.1 ("registration phase time remaining" is measured to the end of the next frame 6, 12 or 18, even when zero). The gateway layer 2 shall issue a GMC-REPORT indication to layer 3 reporting that the registration phase has ended.

The registration phase shall also terminate if a GMA-UNITDATA request primitive is issued to layer 2 containing a DM-PRE ACCEPT message. After following the procedure defined in clause 13.5.8.3, the gateway layer 2 shall issue a GMC-REPORT indication to layer 3 reporting that the registration phase has ended.

The gateway layer 2 shall then enter idle mode.

13.6 Gateway procedures in traffic mode

13.6.1 Introduction

During traffic transmission in DM, the master transmits traffic TCH in slot 1 of frames 1 to 17. Slot 3 of frames 1 to 17, and slots 1 and 3 of frame 18, are available for synchronization and signalling purposes.

In traffic mode, in slot 1 of frames 1 to 17, the master may steal capacity from the circuit for signalling purposes, without changing the mode of operation. The STCH steals a part or all of the TCH bits within a burst, stealing the first half of the burst first. Use of normal training sequence 2 indicates when stealing has occurred and the MAC header in the first half slot indicates whether the second half slot is also stolen.

Refer to clause 13.2 for the configuration of the gateway's lower MAC in synchronization, signalling and traffic mode.

NOTE: For a DM-REP/GATE, slot and frame numbers for traffic reception refer to the master link; slot and frame numbers for traffic transmission refer to the slave link.

13.6.2 Criteria for transmission and reception of traffic

During a circuit mode call:

- a sending gateway layer 2 needs to decide when to start sending traffic (and when to stop);
- a receiving gateway layer 2 needs to know when to process any received TCH (and when to stop).

The basic process is performed by call control messages DM-SETUP, DM-CONNECT ACK, DM-TX CEASED and DM-RELEASE. The "message type" is visible at layer 2 for both transmission and reception, and shall be used by layer 2 to decide when to switch in and out of traffic mode.

Information about the circuit mode call transaction is passed from layer 3 to layer 2 at the start of the traffic: after transmission or reception of DM-SETUP if there is no presence check; or after transmission of DM-CONNECT ACK if there is a presence check. For the purposes of the protocol description, it is assumed that layer 3 passes call information (e.g. TCH type and interleaving depth N) to layer 2 in a GMC-CONFIGURE request primitive containing parameter "circuit mode information".

The upper MAC in the gateway shall inform the lower MAC of the appropriate type of TCH logical channel for transmission or reception (since this affects the coding/decoding method).

After starting to transmit traffic on the DMO side, the gateway shall continue to transmit traffic – TCH and/or STCH – in slot 1 of frames 1 to 17 until termination of the transmission by sending the DM-TX CEASED or DM-RELEASE message.

After starting to receive traffic on the DMO side, the gateway may remain in DM traffic mode, processing TCH and STCH received in slot 1 of frames 1 to 17, until one of the following occurs:

- 1) it receives a DM-TX CEASED or DM-RELEASE message for the call; or
- 2) it receives a GMC-CONFIGURE request primitive from layer 3 indicating a state change; or
- 3) the channel surveillance procedures defined in clause 13.4.2.4 indicate that channel reception from the master DM-MS has been lost or that the channel has become occupied by other users.

In case 3), layer 2 shall report to layer 3 that the call has been lost (using the GMC-REPORT indication primitive). See also clause 13.4.2.4.

NOTE: In case 1): on reception of a DM-TX CEASED or DM-RELEASE message from the master DM-MS, the gateway layer 2 performs actions itself (e.g. leaving traffic receive mode). Also, since the gateway is addressed by the message, layer 2 delivers the received message and DM-SDU to layer 3 in a GMA-UNITDATA indication primitive. This principle applies also to reception of other messages.

13.6.3 Change of U-plane mode

13.6.3.1 Call transaction from DMO to TMO

On receipt of a DM-SETUP message containing its 10-bit gateway address, received in frame X and with "frame countdown" element set to F, and if layer 3 issues a GMC-CONFIGURE request primitive, the layer 2 in a DM-GATE shall assume that traffic will start in slot 1 of frame $Y = (X+F) \bmod 18 + 1$ (if Y is in the range 1 to 17) or otherwise in slot 1 of frame 1.

On receipt of a DM-SETUP message containing its 10-bit gateway address, received in master link frame X and with "frame countdown" element set to F, and if layer 3 issues a GMC-CONFIGURE request primitive, the layer 2 in a DM-REP/GATE shall assume that traffic will start in slot 1 of master link frame $Y = (X+F+DN232) \bmod 18 + 1$ (if Y is in the range 1 to 17) or otherwise in slot 1 of master link frame 1.

13.6.3.2 Call transaction from TMO to DMO

13.6.3.2.1 Call set-up without presence check

At call set-up (or for a call continuation), layer 3 issues a DM-SETUP message in a GMA-UNITDATA request primitive. If the DM channel is available, the gateway shall become master and shall send the message the appropriate number of times using the frame countdown mechanism to indicate the number of frames in which the message is being repeated. The gateway shall then switch to traffic mode in the frame following the frame with "frame countdown" element set to zero. It shall start sending traffic (TCH and/or STCH) in slot 1 of that frame (if it is in the range 1 to 17) or otherwise in slot 1 of frame 1.

NOTE: For a DM-REP/GATE, this requirement refers to frames and slots on the slave link.

13.6.3.2.2 Call set-up with presence check

For a call set-up with presence check, the switch into traffic mode is timed from the transmission of the DM-CONNECT ACK message. If layer 3 issues a DM-CONNECT ACK then layer 2 shall send the message the appropriate number of times using DSBs and using the frame countdown mechanism to indicate the number of frames in which the message is being repeated. Layer 2 shall then switch to traffic mode in the frame following the frame with "frame countdown" element set to zero. It shall start sending traffic (TCH and/or STCH) in slot 1 of that frame (if it is in the range 1 to 17) or otherwise in slot 1 of frame 1.

NOTE 1: For a DM-REP/GATE, this requirement refers to frames and slots on the slave link.

NOTE 2: If layer 3 issues DM-RELEASE instead of DM-CONNECT ACK then layer 2 sends the message using DSBs and does not switch into traffic mode.

13.6.3.3 End of traffic transmission

13.6.3.3.1 Call transaction from DMO to TMO

On receipt of a DM-TX CEASED or DM-RELEASE message from the master DM-MS, received in frame X and with "frame countdown" element set to F, the gateway shall switch out of DM traffic receive mode at the end of frame $(X+F-1) \bmod 18 + 1$.

NOTE 1: For a DM-REP/GATE, this requirement refers to frames and slots on the master link.

NOTE 2: The requirement to remain in traffic mode throughout the frame countdown is specified for a DM-REP/GATE which continues to re-transmit messages on the slave link. It is specified also for a DM-GATE to cover the case of pre-emption when the gateway layer 2 may need to receive also the master DM-MS's DM-PRE ACCEPT message.

A DM-REP/GATE shall switch out of traffic re-transmission mode on the DMO side as follows:

- at the end of slave link frame $(X+F-1) \bmod 18 + 1$, if not performing multi-slot regeneration; or
- at the end of the frame countdown for the re-transmission of the DM-TX CEASED or DM-RELEASE messages on the slave link, if performing multi-slot regeneration (see clause 13.4.8.2.2).

13.6.3.3.2 Call transaction from TMO to DMO

At the end of traffic transmission, layer 3 issues a DM-TX CEASED or DM-RELEASE message. Layer 2 shall send the message on STCH, sending the message at least once per slot in successive traffic slots (i.e. slot 1 of frames 1 to 17) up to the appropriate number of transmissions. It shall then switch out of DM traffic mode.

If the DM-TX CEASED or DM-RELEASE message is sent in slot 1 of frame 6 or 12 then the gateway should send the message also in slot 3 of that frame using the DSB (replacing the channel occupation message). If the STCH message transmission includes frame 18 then the gateway should send the message also in slot 1 and slot 3 of frame 18 (using the DSB).

NOTE 1: The exception is that, if the gateway is also sending DM-PRE ACCEPT or DM-GPRE ACCEPT, then the DM-PRE ACCEPT or DM-GPRE ACCEPT takes precedence in slot 3 of frames 6 and 12 and may take precedence in frame 18.

NOTE 2: DM-RELEASE may be sent in slot 3 of frames other than frames 6, 12 and 18 (see clause 13.4.5.1.3). DM-TX CEASED may also be sent in slot 3 of frames other than frames 6, 12 and 18 if random access requests are not invited.

NOTE 3: For a DM-REP/GATE, these requirements refer to frames and slots on the slave link.

13.6.4 Exchange of information at the GMD-SAP

In the protocol model, the actual user traffic is transferred between the U-plane converter and the gateway's DM layer 2 via the GMD-SAP. The GMD-SAP is used for the transfer of speech frames or circuit mode data. It is also used for the transfer of U-plane signalling.

For the purposes of the protocol description, the following service primitives are used.

NOTE 1: This does not imply any specific implementation. The word "shall" is used with the primitives and their parameters for traceability reasons in the protocol model, but the primitives are not testable.

- The GMD-UNITDATA request primitive shall be used when the U-plane converter wishes to send information on the DMO side.
- The GMD-UNITDATA indication primitive shall be used for the DM layer 2 to deliver information received on the DMO side.
- The GMD-REPORT indication shall be used by the DM layer 2 to issue reports to the U-plane converter e.g. at the start and stop of traffic transmission or at the start of traffic reception.

For the purposes of the protocol description, the unit of exchange at the GMD-SAP is a half slot. Under normal circumstances in traffic mode, two primitive exchanges each containing the equivalent of half a slot capacity are required to fill the physical MAC block that is to be transmitted over the air interface.

The parameters specific to the GMD-UNITDATA primitive are as follows (see also clause 12):

- a) Half slot content:
 - The unit of information in the GMD-UNITDATA primitive is one half slot. The U-plane converter provides a DM-SDU of the correct size for the appropriate logical channel. In particular, for U-plane signalling, the DM-SDU is always 121 bits; layer 2 shall then add a 3-bit MAC header, making the MAC block up to the 124 bits required for STCH. User traffic TCH does not have a MAC header.
- b) Half slot position:
 - Each transferred half slot (in either direction) should be accompanied by a marker identifying it as the first or second half slot of a timeslot. Half slots should be grouped in pairs, equivalent to the data transmitted over the air interface in one slot.
- c) Stolen indication:
 - For transmission on the DMO side, this parameter may indicate whether the half slot is stolen for U-plane signalling or not stolen. Otherwise it may indicate that the U-plane converter requires layer 2 to send C-plane signalling in the half slot.
 - For reception on the DMO side, this parameter shall indicate whether the half slot was stolen for C-plane signalling, stolen for U-plane signalling or not stolen.
- d) Half slot condition:
 - This parameter may be used only in the GMD-UNITDATA indication primitive. It indicates to the receiving U-plane converter whether a half traffic slot was received successfully. It may take the following values:
 - "Good" if the half slot was decoded successfully;

- "Bad" if a valid training sequence was detected but the CRC check failed;
- "Null" if no valid training sequence was detected.

The distinction between "Good" and "Bad" is not appropriate for TCH/7,2.

NOTE 2: For the purposes of the protocol description, channel encoding and decoding are performed in the lower MAC. However, this does not imply any particular implementation.

NOTE 3: For the purposes of the protocol description, the unit of exchange at the GMD-SAP is always a half slot (corresponding to one speech frame). However, this does not imply any particular implementation. For example, implementers may prefer to use a full slot of data as the unit of exchange for circuit mode data TCH.

NOTE 4: It is assumed that the U-plane converter provides valid data in the "half slot content" parameter unless the "stolen indication" is set to "C-plane stealing required".

13.6.4.1 Interface at gateway transmitting traffic on DMO side

At the start of a traffic transmission on the DMO side, the DM layer 2 shall issue a report to the U-plane converter to supply the "circuit mode information" parameter. The report shall also indicate the initial half slot synchronization i.e. whether the first valid U-plane half slot is a first or second half slot. (An initial half slot synchronization of "second half slot" applies only if layer 2 steals the first half slot for C-plane signalling e.g. to send the DM-INFO message).

A report should also be issued to the U-plane converter at the end of traffic transmission.

The procedures defined for a DM-MS in EN 300 396-3 [3], clause 8.6.4.1 shall apply also for a gateway that is transmitting traffic as master on the DMO side, with the following differences:

- i) References to the U-plane application shall be replaced by U-plane converter.
- ii) References to the DMD-UNITDATA request shall be replaced by GMD-UNITDATA request.
- iii) The U-plane converter may issue a GMD-UNITDATA request without any half slot content, but with the stolen indication set to request layer 2 to use C-plane stealing in the half slot. If layer 2 does not have any C-plane signalling that it wishes to send then it shall send the Null PDU.

NOTE: For example this may apply at the start of a transmission if TCH from the U-plane converter is not ready immediately. Then the gateway sends C-plane STCH + STCH e.g. containing Null PDUs. This may occur particularly in the case of interleaving depth $N = 4$ or 8 if the gateway is decoding and re-encoding the traffic.

It may also apply if the gateway does not receive data in a TMO traffic slot. Then the gateway may fill the corresponding DM traffic slot with C-plane STCH + STCH.

It may also apply for a half slot if there has been C-plane stealing in the TMO traffic slot (or stealing with CRC failure).

- iv) If layer 2 receives information comprising Not stolen + Stolen for U-plane from the U-plane converter then it should treat the slot as Stolen for C-plane + Stolen for U-plane.

If the gateway does not perform channel decoding and re-encoding of TCH/S, TCH/2,4 or TCH/4,8 traffic then, for the purposes of the U-plane traffic transfer procedures, the gateway shall treat the traffic as if it had been unprotected data (TCH/7,2).

13.6.4.2 Interface at gateway receiving traffic on DMO side

At the start of traffic reception, the gateway's DM layer 2 shall issue a report to the U-plane converter to supply the "circuit mode information" parameter.

The procedures defined for a DM-MS in EN 300 396-3 [3], clause 8.6.4.2 shall apply also for reception in slot 1 of frames 1 to 17 by a gateway that is authorized to receive TCH on the DMO side, except that references to the U-plane application shall be replaced by U-plane converter and references to the DMD-UNITDATA indication shall be replaced by GMD-UNITDATA indication.

If the gateway does not perform channel decoding and re-encoding of TCH/S, TCH/2,4 or TCH/4,8 traffic then, for the purposes of the U-plane traffic transfer procedures, the gateway shall treat the traffic as if it had been TCH/7,2. So, for each half slot, layer 2 issues a single GMD-UNITDATA indication to the U-plane converter containing any U-plane information (TCH or STCH) and indicating whether the half slot was stolen for C-plane signalling, stolen for U-plane signalling or not stolen. Also the distinction between "good" and "bad" TCH half slot condition is not appropriate.

NOTE 1: The gateway layer 2 is authorized to receive TCH if the DM-SETUP message contained its 10-bit gateway address and layer 3 issued a GMC-CONFIGURE request.

NOTE 2: For the purposes of the protocol description it is assumed that, once data delivery has started for $N = 4$ or 8 , layer 2 always passes data to the U-plane converter (even if the data was not decoded successfully). Therefore, for each traffic slot, layer 2 issues two GMD-UNITDATA indications to the U-plane converter containing traffic data. The same assumption is made for $N = 1$ for a traffic slot in which one half slot was stolen. In both cases, layer 2 issues additional GMD-UNITDATA indication(s) in the case of U-plane stealing but does not issue GMD-UNITDATA indication(s) in the case of C-plane stealing.

In an implementation, the gateway designer may choose to use other appropriate methods when the data is not decoded successfully.

NOTE 3: As in EN 300 396-3 [3]: for the purposes of the protocol description, it is assumed that, if the gateway is decoding and re-encoding the traffic then, in the case of U-plane stealing from circuit mode data with $N = 4$ or 8 , the gateway's layer 2 delays the issuing of the GMD-UNITDATA indication(s) containing the U-plane signalling data by $N - 1$ traffic frames. This is so that the gateway's layer 2 delivers the U-plane signalling to the U-plane converter with the same U-plane circuit mode data as when it was given by the sending U-plane application to the sending upper MAC. This position may be important if the U-plane signalling is carrying end-to-end encryption synchronization.

The need for the procedure arises because the de-interleaving process causes the circuit mode data to be delayed by $N - 1$ traffic frames relative to the U-plane signalling. The gateway needs to compensate for the relative delay introduced by its de-interleaving and re-interleaving of the traffic.

NOTE 4: For a DM-REP/GATE, the slot and frame numbers for traffic reception refer to timeslots on the master link.

13.6.5 Stealing from circuit mode capacity

13.6.5.1 Transmission on STCH

The procedures defined for a DM-MS in EN 300 396-3 [3], clause 8.6.5.1 shall apply also for a gateway that is transmitting traffic as master on the DMO side, except that references to the DMA-REPORT indication shall be replaced by GMA-REPORT indication.

NOTE: As for a DM-MS, the gateway may use the Null PDU as a dummy C-plane message on STCH, in either the first half slot, second half slot or both.

13.6.5.2 Criteria for C-plane stealing

The procedures defined for a DM-MS in EN 300 396-3 [3], clause 8.6.5.2 shall apply also for a gateway that is transmitting traffic as master on the DMO side, with the following differences:

- i) The reference to the half slot importance does not apply.
- ii) Layer 2 should transmit a C-plane message in those half slots for which the U-plane converter set the stolen indication to "C-plane stealing required" in the GMD-UNITDATA request.

For DM-GPRE ACCEPT sent on STCH during traffic transmission, the gateway layer 2 shall send the message in the same traffic slots as the DM-TX CEASED PDU, with the two messages sent in the two halves of the same traffic slots. It should send the DM-GPRE ACCEPT in the first half slot and the DM-TX CEASED in the second half slot.

If the U-plane converter stops issuing GMD-UNITDATA request primitives when the gateway layer 2 is still transmitting traffic on the DMO side then, if regenerating protected data with $N = 4$ or 8 , the gateway should issue $N - 1$ slots containing tail bits (zeros) to the DM lower MAC. Then, for any type of traffic, the gateway layer 2 shall send C-plane signalling; if it does not have other signalling to send then it may send Null PDUs.

NOTE: The DM-TX CEASED (or DM-RELEASE) PDU terminates the traffic transmission. Therefore, if the gateway is decoding and re-encoding the traffic for a circuit mode data call with an interleaving depth of $N = 4$ or 8 and receives a transaction termination PDU on the TMO side, the gateway's layer 3 should normally ensure that the gateway has been able to issue $N - 1$ slots containing tail bits to the DM lower MAC at the end of the data transmission before sending the transaction termination PDU on the DMO side; these tail bits are needed to complete the interleaving of the circuit mode data that has been received from the SwMI. (Exceptions to this rule may occur in the case of pre-emption or interruption).

13.6.5.3 Reception on STCH

The procedures defined for a DM-MS in EN 300 396-3 [3], clause 8.6.5.3 shall apply also for a gateway that is receiving traffic on the DMO side, except that references to the U-plane application shall be replaced by U-plane converter.

13.6.6 DM-REP/GATE procedures for DM re-transmission of DM U-plane traffic

The procedures in this clause define the local DM repeater functions for a DM-REP/GATE for traffic and STCH. They apply only during circuit mode call transactions in which a DM-MS is master.

During traffic mode the DM-REP/GATE shall attempt to receive slot 1 of frames 1 to 17 of the master link. The DM-REP/GATE shall interpret the received slots as TCH and/or STCH as defined in clause 13.6.5.3 – passing appropriate C-plane signalling to layer 3, and passing traffic and U-plane signalling to the U-plane converter. The DM-REP/GATE shall also re-transmit the received information on the DMO side, on the slave link.

For TCH/S, TCH/4,8 and TCH/2,4, the DM-REP/GATE may perform regeneration of the traffic (i.e. channel decoding and re-encoding) before re-transmission on the slave link.

NOTE: In cases where the DM-REP/GATE does not provide traffic regeneration, the DM-REP/GATE may still accept and re-transmit the call transaction. However the error performance may be reduced.

In all cases STCH shall be decoded and re-encoded before re-transmission on the slave link.

13.6.6.1 Call transaction without multi-slot regeneration

This clause applies during a circuit mode call transaction for TCH/S, TCH/7,2 or TCH/4,8 or TCH/2,4 with $N = 1$. It applies also for TCH/4,8 or TCH/2,4 with $N = 4$ or 8 if the DM-REP/GATE is not decoding and re-encoding the traffic before re-transmission on the slave link.

The DM-REP/GATE shall re-transmit the TCH and/or STCH in the corresponding slot 1 on the slave link. The "corresponding slot 1 on the slave link" lags three slots behind slot 1 of the master link. For STCH, the DM-REP/GATE shall use the same half slot as in the master DM-MS's transmission.

If a first or second half slot was not decoded successfully then the gateway designer should choose an appropriate method for transmission in the slave link's first or second half slot respectively e.g. re-transmitting the same bit stream as the DM-REP/GATE received (i.e. type 5 bits received before de-scrambling and decoding, as described in EN 300 396-2 [2], clause 8.2.1).

If the DM-REP/GATE did not receive data on the master link in slot 1 of a frame in the range 1 to 17 then the gateway designer should choose an appropriate method for transmission in the corresponding slot 1 on the slave link e.g. filling the slot with two stolen half slots each containing the C-plane Null PDU.

13.6.6.2 Call transaction with multi-slot regeneration

This clause applies during a circuit mode call transaction for TCH/4,8 or TCH/2,4 with $N = 4$ or 8 if the DM-REP/GATE is decoding and re-encoding the traffic before re-transmission on the slave link.

- The DM-REP/GATE shall re-transmit the TCH and/or STCH in the appropriate slot 1 on the slave link.

- For TCH, when the DM-REP/GATE's upper MAC has received a slot of de-interleaved and decoded circuit mode data from the lower MAC, it shall re-issue that circuit mode data to the lower MAC so that the re-transmission of the data starts in the corresponding slot 1 on the slave link. If the data was air-interface encrypted then the upper MAC shall re-encrypt it before issuing it to the lower MAC.

NOTE 1: The re-encryption is needed because the de-interleaving process causes the re-transmitted user traffic to be delayed by $N - 1$ traffic frames relative to the master DM-MS's transmission. (This delay is in addition to the usual three-slot delay of the slave link relative to the master link).

- For STCH, the DM-REP/GATE shall re-transmit the PDU in the appropriate slot 1 on the slave link, as defined in clause 13.4.8.2.2. It shall use the same half slot as in the master DM-MS's transmission.

NOTE 2: For example, the DM-REP/GATE delays U-plane signalling by $N - 1$ traffic frames (in addition to the usual three-slot delay of the slave link relative to the master link). This delay is specified so that the DM-REP/GATE re-transmits the U-plane data stream on the slave link with the U-plane signalling in the same position as when the master DM-MS transmitted it on the master link.

The DM-REP/GATE also delays DM-TX CEASED and DM-RELEASE messages by $N - 1$ traffic frames (except in the case of a pre-emption acceptance), enabling it to issue $N - 1$ slots containing tail bits to its lower MAC before re-transmitting the transaction termination messages.

14 DM PDU descriptions

This clause describes the PDUs which apply to the DM air interface layers 2 and 3 for operation with a gateway.

14.1 Layer 2 PDUs sent in DSB

14.1.1 DMAC-SYNC PDU

EN 300 396-3 [3], clause 9.1.1 shall apply.

NOTE: The DMAC-SYNC PDU is sent by DM-MSs and by the gateway.

Additionally the following applies:

- 1) Element "communication type" shall be set to 10_2 for operation with a DM-GATE, or to 11_2 for operation with a DM-REP/GATE. This shall apply for signalling both to and from the gateway.
- 2) For operation with a DM-REP/GATE:
 - the "master/slave link flag" shall be included and shall be set to indicate whether the PDU is being sent on the master link or the slave link;
 - for a PDU sent on the master link, the "slot number" and "frame number" elements shall be set using the master link's slot and frame numbering;
 - for a PDU sent on the slave link, the "slot number" and "frame number" elements shall be set using the slave link's slot and frame numbering.
- 3) Element "gateway generated message flag" shall be included, and shall be set appropriately.
- 4) Element "A/B channel usage" shall be set to 00_2 .
- 5) Addressing elements shall be included within the SCH/H block as follows:
 - the 10-bit "gateway address" element shall be included;
 - when the DMAC-SYNC PDU is carrying a gateway-specific message, a single 24-bit SSI shall be included: the source address when sent by a DM-MS or the destination address when sent by the gateway;

- when the DMAC-SYNC PDU is carrying a non-gateway-specific message, both a source SSI and a destination SSI shall be included;
- the MNI element shall be included if either the source or destination address is a true address i.e. if the source address type = 00₂ and/or the destination address type = 00₂.

14.1.2 DPRES-SYNC PDU

The DPRES-SYNC PDU is transmitted by the gateway using the 60 available bits of the logical channel SCH/S and the 124 available bits of the logical channel SCH/H. Its purpose is to announce the presence of the gateway to MSs on the DM channel. Its content shall be as given in tables 5 and 6.

Table 5: Gateway DPRES-SYNC PDU contents in SCH/S

Information element	Length	Type	Remark
System code	4	M	
SYNC PDU type	2	M	Value 01 ₂ indicates DPRES-SYNC PDU.
Communication type	2	M	Value 00 ₂ not valid in DPRES-SYNC PDU (note 3). Set to 01 ₂ when sent by a DM-REP; see EN 300 396-4 [4] for the DM-REP presence signal. Set to 10 ₂ or 11 ₂ when sent by a gateway (note 1).
M-DMO flag	1	M	
SwMI availability flag	1	C	Always present when sent by a gateway.
DM-REP function flag	1	C	Always present when sent by a gateway.
Two-frequency repeater flag	1	C	Included if communication type = 11 ₂ or DM-REP function flag = 1.
Reserved	1	C	Included if communication type = 10 ₂ and DM-REP function flag = 0. Default value = 0.
Repeater operating modes	2	C	Included if DM-REP function flag = 1.
Reserved	2	C	Included if DM-REP function flag = 0. Default value = 00 ₂ .
Spacing of uplink	6	C	Included if two-frequency repeater flag is present and is set to 1.
Reserved	6	C	Included if two-frequency repeater flag is not present or is set to 0. Default value = 000000 ₂ .
Master/slave link flag	1	M	This element has no meaning when sent by a DM-GATE, except when it is providing a DM-REP function for a call. Default value for DM-GATE = 0.
Channel usage	2	M	
Channel state	2	M	
Slot number	2	M	
Frame number	5	M	
Power class	3	M	Note 2, note 4
Power control flag	1	M	Note 2
Registration phase terminated flag	1	C	Included if channel state = 00 ₂ .
Reserved	1	C	Included if channel state ≠ 00 ₂ . Default value = 0.
Frame countdown	2	M	
Reserved	2	C	Included if channel state = 00 ₂ and (DM-REP function flag = 0 or master/slave link flag = 1). Default value = 00 ₂ .
Timing for DM-REP function	2	C	Included if channel state = 00 ₂ and DM-REP function flag = 1 and master/slave link flag = 0.
Priority level	2	C	Included if channel state ≠ 00 ₂ . Note 2.
Registrations permitted	2	C	Always present when sent by a gateway.
Registration label	4	C	Always present when sent by a gateway
Registration phase time remaining	4	C	Included if channel state = 11 ₂ .
Values of DN232 and DN233	4	C	Included if channel state ≠ 11 ₂ and (communication type = 11 ₂ or DM-REP function flag = 1).

Information element	Length	Type	Remark
Reserved	4	C	Included if channel state \neq 11 ₂ and communication type = 10 ₂ and DM-REP function flag = 0. Default value = 0000 ₂ .
Registration access parameter	3	C	Included if channel state = 11 ₂ .
Value of DT264	3	C	Included if channel state \neq 11 ₂ .
Registrations forwarded flag	1	C	Always present when sent by a gateway.
Gateway encryption state on SwMI	1	C	Always present when sent by a gateway. See EN 300 396-6 [6] clause 6.3 for element coding.
System wide services not available	1	C	Always present when sent by a gateway.
Reserved	3	C	Always present when sent by a gateway. Default value = 000 ₂ .
<p>NOTE 1: Following the communication type element, the following elements in the DPRES-SYNC PDU are shown in table 5 only if relevant to the presence signal sent by a gateway i.e. if communication type = 10₂ or 11₂. Similarly, conditions for the presence of the following elements are shown only for communication type 10₂ and 11₂.</p> <p>NOTE 2: The power class, power control flag and priority level are message dependent elements in EN 300 396-3 [3]. See EN 300 396-3 [3], clause 9.6 for their definition.</p> <p>NOTE 3: Communication type is set to 00₂ for some cases of managed direct mode operation.</p> <p>NOTE 4: A DM-MS may use power class and maximum DM-MS power class together with received signal strength information to assess if it is within range of the gateway. The method of doing so is outside the scope of the present document.</p>			

Table 6: Gateway DPRES-SYNC PDU contents in SCH/H

Information element	Length	Type	Remark
Gateway address	10	C	Always present when sent by a gateway.
MNI of SwMI	24	C	Always present when sent by a gateway.
Validity time unit	2	M	
Number of validity time units	6	C	Included if Validity time unit \neq 11 ₂ .
Reserved	6	C	Included if Validity time unit = 11 ₂ , default value 000000 ₂ .
Maximum DM-MS power class	3	M	Note
Reserved	1	M	Default value = 0.
Usage restriction type (URT)	4	M	
SCKN	5	C	Included if URT = 1000 ₂ , 1001 ₂ , 1010 ₂ or 1011 ₂ . This element is defined in EN 300 396-6 [6].
EDSI-URTC Initialisation Value (EUIV)	19	C	Included if URT = 1000 ₂ , 1001 ₂ , 1010 ₂ or 1011 ₂ . This element is defined in EN 300 396-6 [6].
Addressing for URT = 0010 ₂ or 1000 ₂	24	C	Included if URT = 0010 ₂ . Or 1000 ₂ This element contains the valid MNI.
Addressing for URT = 0011 ₂ or 1001 ₂	48	C	Included if URT = 0011 ₂ . Or 1001 ₂ This element contains one TSI.
Addressing for URT = 0100 ₂ or 0101 ₂	72	C	Included if URT = 0100 ₂ or 0101 ₂ . This element contains one TSI and one SSI.
Addressing for URT = 0110 ₂	72	C	Included if URT = 0110 ₂ . This element contains three SSIs.
Addressing for URT = 1010 ₂	24	C	Included if URT = 1010 ₂ . This element contains one SSI.
Addressing for URT = 1011 ₂	48	C	Included if URT = 1011 ₂ . This element contains two SSIs
Proprietary	72	C	Included if URT = 0111 ₂ . The proprietary element is available for proprietary uses; its use and structure are not defined in the present document.
Reserved	72	C	Included if URT = 0000 ₂ or 0001 ₂ . Default value = all zeros.
Reserved	48	C	Included if URT = 0010 ₂ . Default value = all zeros.
Reserved	24	C	Included if URT = 0011 ₂ , 1000 ₂ , or 1010 ₂ . Default value = all zeros.
Reserved	2	C	Always present when sent by a gateway. Default value = 00 ₂ .
NOTE: A DM-MS may use power class and maximum DM-MS power class together with received signal strength information to assess if it is within range of the gateway. The method of doing so is outside the scope of the present document.			

14.2 Layer 2 PDUs sent in DNB

EN 300 396-3 [3], clause 9.2 shall apply.

NOTE: These PDUs may be sent by DM-MSs and by the gateway.

In the DMAC-DATA PDU:

- a destination address element shall always be included (whereas it is optional whether a source address element is included);
- the MNI element shall be included if either the source or destination address is a true address i.e. if the source address type = 00₂ and/or the destination address type = 00₂.

14.3 Layer 2 information element coding

EN 300 396-3 [3], clause 9.3 shall apply with the following clarification.

The value of System code, see EN 300 396-3 [3], clause 9.3.29, used by DM-MS and gateways that comply with the present document shall be 1101_2 .

The following clauses shall also apply.

14.3.1 Addressing for $URT = 0010_2$ or 1000_2

The addressing for $URT = 0010_2$ or 1000_2 element contains a single 24-bit mobile network identity (MNI). DM-MSs with this MNI are permitted to initiate transactions and continue ongoing transactions through the gateway for the indicated validity time. In the case of $URT = 1000_2$ the MNI is encrypted as defined in EN 300 396-6 [6].

14.3.2 Addressing for $URT = 0011_2$ or 1001_2

The addressing for $URT = 0011_2$ or 1001_2 element contains a single 48-bit TSI. This is the TSI of a group of DM-MSs (for a group TSI) or an individual DM-MS (for an individual TSI) that is permitted to use the gateway. DM-MSs with an address corresponding to this TSI (either an individual or group address) are permitted to initiate transactions and continue ongoing transactions through the gateway for the indicated validity time. In the case of $URT = 1001_2$ the TSI is encrypted as defined in EN 300 396-6 [6].

NOTE: The 48-bit TSI comprises a 24-bit MNI followed by a 24-bit SSI.

14.3.3 Addressing for $URT = 0100_2$ or 0101_2

The addressing for $URT = 0100_2$ or 0101_2 element contains one 48-bit TSI and one 24-bit SSI.

The first TSI shall be generated by receiving DM-MSs using the MNI for SSI 1 element and SSI 1.

Then a TSI shall be generated from SSI 2 as follows:

- for $URT = 0100_2$ a TSI shall be generated from SSI 2 using the MNI for SSI 1;
- for $URT = 0101_2$ a TSI shall be generated from SSI 2 using the MNI of SwMI element from the SCH/H block.

DM-MSs with an address corresponding to one of these two TSIs (either an individual or group address) are permitted to initiate transactions and continue ongoing transactions through the gateway for the indicated validity time.

Information element	Length	Value	Remark
MNI for SSI 1	24		
SSI 1	24		
SSI 2	24		

14.3.4 Addressing for $URT = 0110_2$

The addressing for $URT = 0110_2$ element contains three 24-bit SSIs. For each SSI, a TSI shall be generated by receiving DM-MSs using the MNI of SwMI element from the SCH/H block. DM-MSs with an address corresponding to one of these three TSIs (either an individual or group address) are permitted to initiate transactions and continue ongoing transactions through the gateway for the indicated validity time.

Information element	Length	Value	Remark
SSI 1	24		
SSI 2	24		
SSI 3	24		

14.3.4A Addressing for URT = 1010₂

The addressing for URT = 1010₂ element contains a single 24-bit SSIs. The SSI is encrypted as defined in EN 300 396-6 [6].

A TSI shall be generated by receiving DM-MSs using the MNI of SwMI element from the SCH/H block. DM-MSs with an address corresponding to this TSI (either an individual or group address) are permitted to initiate transactions and continue ongoing transactions through the gateway for the indicated validity time.

14.3.4B Addressing for URT = 1011₂

The addressing for URT = 1011₂ element contains two 24-bit SSIs. The SSIs are encrypted as defined in EN 300 396-6 [6].

For each SSI, a TSI shall be generated by receiving DM-MSs using the MNI of SwMI element from the SCH/H block. DM-MSs with an address corresponding to one of these two TSIs (either an individual or group address) are permitted to initiate transactions and continue ongoing transactions through the gateway for the indicated validity time.

14.3.5 Channel state

The channel state element indicates the current state of the channel on which the presence signal is being sent, as defined by the channel usage element.

When the channel usage element is set to 00₂ the channel state element applies to the complete carrier. When the channel usage element is set to 01₂ or 10₂ the channel state element applies only to the indicated DM channel (i.e. channel A or channel B).

Information element	Length	Value	Remark
Channel state	2	00 ₂	Channel free
		01 ₂	Channel in occupation
		10 ₂	Channel in reservation
		11 ₂	Channel in registration phase

14.3.6 Channel usage

The channel usage element indicates the DM channel on which the presence signal is being sent (i.e. channel A or channel B). It may also indicate that the presence signal applies to the complete carrier.

Information element	Length	Value	Remark
Channel usage	2	00 ₂	Presence signal applies to the carrier i.e. - channel A active in normal mode; or - presence signal sent on a free carrier
		01 ₂	Channel A, frequency efficient mode
		10 ₂	Channel B
		11 ₂	Reserved

14.3.7 DM-REP function flag

The DM-REP function flag indicates whether DM-MSs are permitted to attempt to use the gateway to provide a DM-REP function.

If the DM-REP function is available then a DM-MS may invoke the protocol for operation with a DM-REP, with the communication type element set to 01_2 and the repeater address element in DMAC-SYNC PDUs set to the 10-bit address of the gateway. For the duration of the call, the DM-MSs in the call shall follow the protocol defined in EN 300 396-4 [4] or EN 300 396-7 [i.3] as appropriate, with the following differences:

- When a DM-MS becomes master on a free channel, it shall use the timing defined by the gateway in the "timing for DM-REP function" element if it has received a free-channel presence signal (or other suitable signalling) sufficiently recently.
- During the call, the master DM-MS monitors timeslot 3 of the appropriate master link frames for a DSB from the gateway (as defined in EN 300 396-4 [4] or EN 300 396-7 [i.3]). It uses DSBs from the gateway to re-align its frequency synchronization. Also, it shall re-align its transmission timing if it perceives a difference of more than 1/4 symbol between its own slot timing and the timing of DSBs received from the gateway.
- The master DM-MS shall set the "timing flag" to 0 to indicate that timing change requests are not allowed.
- A DM-MS requesting changeover or pre-emption within the ongoing call shall not include a "timing adjustment" element within the request message.

During a call in which the gateway is providing the DM-REP function, the gateway shall follow the protocol defined in EN 300 396-4 [4] or EN 300 396-7 [i.3] as appropriate, except that, when it is required by the protocol to send the presence signal, it shall continue to use the gateway presence signal. (The gateway shall set the master/slave link flag to indicate whether the presence signal is sent on the master link or slave link). Also, the gateway shall provide the timing synchronization for the DM channel(s).

NOTE 1: A gateway which offers the DM-REP function needs to use the communication type element in received DMAC-SYNC PDUs to determine whether a calling DM-MS requires DM-REP or gateway operation.

NOTE 2: The gateway may offer a DM-REP function when out of range of the SwMI. It may also offer a DM-REP function when within range of the SwMI if it has the necessary physical capabilities.

DM-MS designers should note that the gateway may offer a DM-REP function at some times but not at other times. This may apply particularly for a DM-GATE. The DM-MS should assume the value received in the most recent presence signal from the gateway.

Information element	Length	Value	Remark
DM-REP function flag	1	0	DM-REP function not available
		1	DM-REP function available

14.3.8 Not used

14.3.9 Maximum DM-MS power class

The maximum DM-MS power class element specifies the maximum power class that may be used by a DM-MS whose use of the gateway is permitted by this PDU. When using the gateway, the DM-MS shall transmit at this power class or lower.

NOTE: This implies a requirement for switchable power classes under protocol control.

Power class value 000_2 (power class not defined) may be used by a gateway which means that the maximum power class used by a DM-MS is not defined.

Information element	Length	Value	Remark
Maximum DM-MS power class	3	000 ₂	Null value (i.e. power class not defined)
		001 ₂	Power class 1 (note)
		010 ₂	Power class 2
		011 ₂	Power class 3
		100 ₂	Power class 4
		101 ₂	Power class 5
		110 ₂	Reserved
		111 ₂	Reserved
NOTE: Not valid for DM-MS.			

The nominal output power for each power class shall be as defined in clause 6.4.2 of EN 300 396-2 [2].

14.3.10 M-DMO flag

The M-DMO flag indicates whether the presence signal relates to managed direct mode operation (see EN 300 396-10 [i.4]) or to normal gateway operation as defined in the present document.

Information element	Length	Value	Remark
M-DMO flag	1	0	Not a managed direct mode presence signal
		1	Managed direct mode presence signal

14.3.11 MNI of SwMI

The MNI of SwMI element contains the mobile network identity of the SwMI that the gateway is currently using i.e. the SwMI to which the gateway may provide access.

14.3.12 Number of validity time units

The number of validity time units element indicates the validity time for use of the gateway by a DM-MS whose use of the gateway is permitted by this PDU.

The DM-MS shall use the value from the most recently received PDU permitting it to use the gateway. This shall apply even if it results in the DM-MS reducing its validity time. If the number of validity time units is set to 0 then this withdraws permission to use the gateway.

NOTE: A DM-MS's validity time is not affected by receipt of a presence signal if it is not addressed by the usage restrictions in that presence signal.

Information element	Length	Value	Remark
Number of validity time units	6	any	Multiplies the validity time unit

14.3.13 Registration access parameter

The registration access parameter element is used by the gateway during a registration phase to indicate the value of "M" to be used by DM-MSs sending solicited registration requests; see clauses 8.5.8.1.2 and 8.5.8.1.5.

Information element	Length	Value	Remark
Registration access parameter	3	000 ₂	M = 0
		001 ₂	M = 1
		010 ₂	M = 2
		etc....	etc....
		111 ₂	M = 7

14.3.14 Registration label

The registration label element is used by the gateway to indicate whether previously accepted registrations are still valid.

Information element	Length	Value	Remark
Registration label	4	0000 ₂	Registration label = 0
		0001 ₂	Registration label = 1
		0010 ₂	Registration label = 2
		etc.	etc.
		1111 ₂	Registration label = 15

14.3.14A Registration phase terminated flag

The Registration phase terminated flag indicates whether the free channel presence signal is being sent to indicate that a registration phase is being terminated prematurely, due to the gateway accepting a pre-emption or wishing to initiate a DMO transaction, or as a normal free channel presence signal.

Information element	Length	Value	Remark
Registration phase terminated flag	1	0	Normal free channel presence signal
		1	Registration phase terminated prematurely

14.3.15 Registration phase time remaining

The registration phase time remaining element is used by the gateway during a registration phase to indicate its current estimate of how long it will hold the DM channel in that registration phase.

When the element indicates a specific value, this indicates the registration time remaining, in units of 6 frames, measured to the end of a frame 6, 12 or 18. If sent in a frame 6, 12 or 18, the registration time remaining shall be measured from the end of that frame. If sent in a frame other than frame 6, 12 or 18, the registration time remaining shall be measured from the end of the next occurring frame 6, 12 or 18.

Information element	Length	Value	Remark
Registration phase time remaining	4	0000 ₂	End of registration phase
		0001 ₂	6 frames remaining
		0010 ₂	12 frames remaining
		0011 ₂	18 frames remaining
		0100 ₂	19 to 36 frames remaining
		0101 ₂	37 to 54 frames remaining
		0110 ₂	55 to 72 frames remaining
		0111 ₂	73 to 90 frames remaining
		1000 ₂	91 to 108 frames remaining
		1001 ₂	109 to 126 frames remaining
		1010 ₂	127 to 144 frames remaining
		1011 ₂	145 to 162 frames remaining
		1100 ₂	163 to 180 frames remaining
		1101 ₂	181 to 198 frames remaining
		1110 ₂	199 to 216 frames remaining
1111 ₂	217 to 234 frames remaining		

14.3.16 Registrations forwarded flag

The registrations forwarded flag element indicates whether the gateway intends to forward to the SwMI the identities of DM-MSs that send registration requests, in order that those DM-MSs may receive individually addressed calls from the TMO system.

NOTE: Even if the gateway does not forward DM-MS individual addresses to the SwMI, it may still choose to invite registration requests in order to decide which groups to support.

Information element	Length	Value	Remark
Registrations forwarded flag	1	0	Gateway will not forward DM-MS individual addresses to SwMI
		1	Gateway intends to forward DM-MS individual addresses to SwMI

14.3.17 Registrations permitted

The registrations permitted element indicates whether DM-MSs are permitted to attempt to send registration requests to the gateway (if authorized by the current usage restrictions).

Information element	Length	Value	Remark
Registrations permitted	2	00 ₂	Registrations not permitted
		01 ₂	Unsolicited registrations not permitted (i.e. registrations not permitted outside registration phase)
		10 ₂	Registrations permitted
		11 ₂	Registrations solicited

14.3.18 Repeater operating modes

The repeater operating modes element indicates whether a DM-MS requesting the DM-REP function offered by the gateway may make type 1 or type 2 calls (see EN 300 396-4 [4] and EN 300 396-7 [i.3]).

Information element	Length	Value	Remark
Repeater operating modes	2	00 ₂	Type 1 DM-REP; DM-MSs may make only type 1 calls
		01 ₂	Type 2 DM-REP; DM-MSs may make only type 2 calls
		10 ₂	Type 2 DM-REP; DM-MSs may make either type 1B or type 2 calls (see note)
		11 ₂	Reserved

NOTE: The gateway may offer a type 2 DM-REP function when out of range of the SwMI. It is not precluded from offering a type 2 DM-REP function when within range of the SwMI. However there is no procedure for a DM-MS to pre-empt a type 2 call in order to make a normal mode call (such as a call using the gateway function), so use of this option will stop DM-MSs from using gateway operation until the type 2 call(s) have ended.

DM-MS designers should note that the gateway may offer a type 2 DM-REP function at some times but not at other times. The DM-MS should assume the value received in the most recent presence signal from the gateway.

14.3.19 Spacing of uplink

The spacing of uplink element indicates the frequency of the DM "uplink" RF carrier f_1 from DM-MSs to a two-frequency DM-REP/GATE relative to the selected DM "downlink" RF carrier f_2 from the gateway to DM-MSs (i.e. the frequency on which the presence signal is being sent). It may apply also for a DM-GATE during calls in which the gateway is providing a two-frequency DM-REP function.

NOTE: For a DM-GATE, the spacing of uplink element refers only to operation during calls in which the gateway is providing a two-frequency DM-REP function. It does not apply to calls using the gateway function. For a gateway call through a DM-GATE, all DM transmissions are sent on the selected DM RF carrier (as defined in clauses 8 and 13 of this part of the present document).

The spacing of uplink element comprises two sub-elements. The first defines the duplex spacing, and the second defines whether f_1 is above or below f_2 .

Information element	Length	Value	Remark
Duplex spacing	5	00000 ₂	Reserved
		00001 ₂	1,6 MHz
		00010 ₂	4,5 MHz
		00011 ₂	8 MHz
		00100 ₂	10 MHz
		00101 ₂	18 MHz
		00110 ₂	30 MHz
		00111 ₂	39 MHz
		01000 ₂	45 MHz
		others	Reserved
Normal/reverse operation	1	0	$f_1 = f_2 + \text{duplex spacing}$
		1	$f_1 = f_2 - \text{duplex spacing}$

14.3.19 System wide services not available

The system wide services not available element indicates whether the SwMI is temporarily unable to support system wide services or is operating normally.

NOTE 1: This is the inverse of the coding for System wide services in EN 300 392-2 [5], clause 18.5.2.

NOTE 2: Prior to receiving the system wide services not available element from a particular gateway, DM-MS may assume that the SwMI is operating normally.

Information element	Length	Value	Remark
System wide services not available	1	0	Normal mode
		1	System wide services temporarily not supported

14.3.20 SwMI availability flag

The SwMI availability flag element indicates whether the gateway is currently within range of the SwMI (i.e. receiving an appropriate common control channel or assigned channel).

NOTE: When the gateway is not within range of the SwMI the DM-REP function may still be available if indicated by the DM-REP function flag.

Information element	Length	Value	Remark
SwMI availability flag	1	0	SwMI not available
		1	SwMI available

14.3.21 Timing for DM-REP function

The timing for DM-REP function element indicates the timing that a master DM-MS should use if it wishes to use the DM-REP function offered by the gateway. If the value of this element is X then this indicates that the master DM-MS should set the master link's slot and frame numbering X timeslots ahead of the slot and frame numbering indicated by this presence signal.

NOTE: It is expected that a DM-REP/GATE will normally set this element to 11₂ in presence signals sent on the slave link i.e. to indicate that it wishes the master DM-MS to use the same timing when using its DM-REP function as when using its DM-REP/GATE function. A DM-GATE may set this element to the value which best matches its physical capabilities.

Information element	Length	Value	Remark
Timing for DM-REP function	2	00 ₂	Set master link slot and frame numbering to the slot and frame numbering indicated by this presence signal
		01 ₂	Set master link slot and frame numbering 1 timeslot ahead of the slot and frame numbering indicated by this presence signal
		10 ₂	Set master link slot and frame numbering 2 timeslots ahead of the slot and frame numbering indicated by this presence signal
		11 ₂	Set master link slot and frame numbering 3 timeslots ahead of the slot and frame numbering indicated by this presence signal

14.3.22 Two-frequency repeater flag

The two-frequency repeater flag element indicates whether one or two DM RF carriers are used for calls through a DM-REP/GATE (or through a DM-GATE when it is providing a DM-REP function).

Information element	Length	Value	Remark
Two-frequency repeater flag	1	0	One DM RF carrier i.e. type 1A DM-REP/GATE (or type 1A DM-REP)
		1	Pair of duplex-spaced DM RF carriers i.e. type 1B DM-REP/GATE (or type 1B or type 2 DM-REP)

14.3.23 Usage restriction type (URT)

The usage restriction type element indicates the type of restrictions on which DM-MSs are permitted to attempt to use the gateway.

Information element	Length	Value	Remark
Usage restriction type	4	0000 ₂	No restrictions (i.e. open)
		0001 ₂	Restricted by prior arrangement (i.e. use of this gateway is available only by prior arrangement)
		0010 ₂	Restricted to single MNI
		0011 ₂	Restricted to single address (TSI)
		0100 ₂	Restricted to 2 addresses (TSI + SSI)
		0101 ₂	Restricted to 2 addresses (TSI + SSI)
		0110 ₂	Restricted to 3 addresses (SSIs)
		0111 ₂	Available for proprietary uses
		1000 ₂	URTC restricted to single MNI
		1001 ₂	URTC restricted to single address (TSI)
		1010 ₂	URTC restricted to 1 address (SSI)
		1011 ₂	URTC restricted to 2 addresses (SSI + SSI)
others	Reserved		

14.3.24 Validity time unit

The validity time unit element indicates the time unit used for the validity time.

Information element	Length	Value	Remark
Validity time unit	2	00 ₂	Multiframe
		01 ₂	60 multiframe
		10 ₂	3600 multiframe
		11 ₂	Validity time not restricted

14.3.25 Value of DT264

The value of DT264 element indicates the value of the gateway's timer DT264.

NOTE 1: DT264 is the maximum interval between transmissions of the gateway presence signal on a free carrier. This element may be used by DM-MSs in algorithms for deciding when they have gone out of range of the gateway.

NOTE 2: The gateway is not precluded from using a value of DT264 not represented by the "value of DT264" element. If it does so then it should set the "value of DT264" element to indicate the next represented value of DT264 above the actual value.

Information element	Length	Value	Remark
Value of DT264	3	000 ₂	Value of timer DT264 not indicated
		001 ₂	2 multiframe duration
		010 ₂	5 multiframe duration
		011 ₂	10 multiframe duration
		100 ₂	15 multiframe duration
		101 ₂	20 multiframe duration
		110 ₂	30 multiframe duration
		111 ₂	60 multiframe duration

14.3.26 Values of DN232 and DN233

The values of DN232 and DN233 element indicate the values of the layer 2 constants DN232 and DN233 that are being used by a DM-REP/GATE (or by a gateway offering a DM-REP function). The element comprises two sub-elements, the first indicating the value of DN232 and the second indicating the value of DN233.

A DM-MS shall use the values of DN232 and DN233 from the DM-REP/GATE's presence signal in preference to the values given by configuration (or the default values).

NOTE: DN232 is the number of frames in which the gateway transmits a DM-MS's DM-SETUP message on the slave link. DN233 is the number of frames in which it transmits a DM-MS's short data DSB or unsolicited registration on the slave link.

Information element	Length	Value	Remark
Value of DN232	2	00 ₂	Reserved
		01 ₂	DN232 = 2
		10 ₂	DN232 = 3
		11 ₂	DN232 = 4
Value of DN233	2	00 ₂	Reserved
		01 ₂	DN233 = 2
		10 ₂	DN233 = 3
		11 ₂	DN233 = 4

14.4 Messages generated by layer 2

EN 300 396-3 [3], clause 9.4 shall apply with the following restrictions:

- i) Message DM-RESERVED is sent only by the gateway (either during a call set-up through that gateway or after a call transaction).
- ii) Message DM-TIMING REQUEST is not used.
- iii) Message DM-TIMING ACK is sent only by the gateway, to announce a timing change.

14.5 Layer 3 PDUs

EN 300 396-3 [3], clause 9.5 shall apply with the following restrictions and differences:

- i) Messages DM-SETUP PRES, DM-CONNECT ACK and DM-TX ACCEPT are not sent by DM-MSs.
- ii) Messages DM-CONNECT, DM-DISCONNECT and DM-TX REQUEST are not sent by the gateway.
- iii) When messages DM-SETUP, DM-SETUP PRES, DM-CONNECT ACK and DM-OCCUPIED are generated by the gateway, the "external source flag" element may be used to indicate a call from an external network (i.e. beyond the TMO system).
- iv) Message DM-INFO may include an external subscriber number, as shown in table 7.

Table 7: DM-INFO PDU contents

Information element	Length	Type	Remark
DM-SDU elements			
Information type	3	M	
Calling party TSI	48	C	True calling party address, included for information type = 000 ₂ or 010 ₂
External subscriber number	varies	C	Included for information type = 001 ₂ or 010 ₂

- v) Messages DM-SDS UDATA and DM-SDS DATA may contain additional addressing information, as shown in table 8.

Table 8: DM-SDS UDATA and DM-SDS DATA PDU contents

Information element	Length	Type	Remark
Message dependent elements			
SDS time remaining	4	M	
SDS transaction type	1	M	
Priority level	2	M	
FCS flag	1	M	
DM-SDU elements			
Additional addressing flag	1	M	
Additional address type(s)	4	C	Included if additional addressing flag = 1
Calling party TSI	48	C	Conditional on additional address type(s)
Area selection	4	C	Conditional on additional address type(s)
External subscriber number	varies	C	Conditional on additional address type(s)
Short Data Type Identifier	4	M	SDTI
User defined data 1	16	C	Conditional on SDTI
User defined data 2	32	C	Conditional on SDTI
User defined data 3	64	C	Conditional on SDTI
Length indicator	11	C	Conditional on SDTI
User defined data 4	variable	C	Conditional on SDTI
Precoded status	16	C	Conditional on SDTI
FCS	32	C	Included if FCS flag = 1. The mathematical definition of the FCS is given in EN 300 396-3 [3], annex B

The following clauses shall also apply.

14.5.1 DM-GSETUP

Message Name: DM-GSETUP

Response to: -

Response Expected: DM-GCONNECT or DM-GACK

Short Description: The DM-GSETUP PDU shall be the call set-up message sent to the gateway.

Table 9: DM-GSETUP PDU contents

Information element	Length	Type	Remark
Message dependent elements			
Gateway message subtype	5	M	Value 00000 ₂ indicates DM-GSETUP PDU
Circuit mode type	4	M	
Reserved	4	M	Default value = 0000 ₂
Priority level	2	M	
DM-SDU elements			
End-to-end encryption flag	1	M	
Call type flag	1	M	
Reserved	2	M	Default value = 00 ₂
Request label	4	M	
Called party address type flag	1	M	
Called party SSI	24	M	
Called party MNI	24	C	Included if called party address type flag = 1
Area selection	4	M	
Additional addressing flag	1	M	
Additional address type(s)	4	C	Included if additional addressing flag = 1
Calling party TSI	48	C	Conditional on additional address type(s)
External subscriber number	varies	C	Conditional on additional address type(s)

14.5.2 DM-GCONNECT

Message Name: DM-GCONNECT

Response to: DM-GSETUP

Response Expected: DM-SETUP or DM-RELEASE

Short Description: The DM-GCONNECT PDU shall be the message sent by the gateway to accept a DM-GSETUP requesting a call.

Table 10: DM-GCONNECT PDU contents

Information element	Length	Type	Remark
Message dependent elements			
Gateway message subtype	5	M	Value 00001 ₂ indicates DM-GCONNECT PDU
Power class	3	M	
Power control flag	1	M	
Reserved	1	M	Default value = 0 ₂
Gateway encryption state on SwMI	1	M	See EN 300 396-6 [6], clause 6.3 for element coding
Circuit mode type	4	M	
Reserved	4	M	Default value = 0000 ₂
DM-SDU elements			
End-to-end encryption flag	1	M	
Call type flag	1	M	
Request label	4	M	
Reserved	4	M	Default value = 0000 ₂

14.5.3 DM-GACK

Message Name:	DM-GACK
Response to:	DM-GSETUP, DM-GTX REQUEST or DM-GPREEMPT
Response Expected:	-
Short Description:	The DM-GACK PDU shall be the message sent by the gateway as an intermediate acknowledgement.

Table 11: DM-GACK PDU contents

Information element	Length	Type	Remark
Message dependent elements			
Gateway message subtype	5	M	Value 00010 ₂ indicates DM-GACK PDU
Timing change announced	1	M	
Timing adjustment	12	C	Included if timing change announced = 1
Reservation announced	1	M	
Channel reservation type	1	C	Included if reservation announced = 1
Reservation time remaining	6	C	Included if reservation announced = 1
Requests flag	1	C	Included if reservation announced = 1
Changeover requests flag	1	C	Included if reservation announced = 1
Requests bitmap	8	C	Included if reservation announced = 1 and requests flag = 1
Power class	3	C	Included if reservation announced = 1
Power control flag	1	C	Included if reservation announced = 1
Reserved	1	C	Included if reservation announced = 1 Default value = 0
Priority level	2	C	Included if reservation announced = 1
Reserved	4	M	Default value = 0000 ₂
DM-SDU elements			
Type of DM-GACK	2	M	
Value of DM-MS waiting timer	3	M	

14.5.4 DM-GRELEASE

Message Name:	DM-GRELEASE
Response to:	-
Response Expected:	-

Short Description: The DM-GRELEASE PDU shall be the message sent by the gateway to indicate that it can no longer support the call.

Table 12: DM-GRELEASE PDU contents

Information element	Length	Type	Remark
Message dependent elements			
Gateway message subtype	5	M	Value 00011 ₂ indicates DM-GRELEASE PDU
DM-SDU elements			
Gateway release cause	4	M	

14.5.5 DM-GTX REQUEST

Message Name: DM-GTX REQUEST

Response to: -

Response Expected: DM-GTX ACCEPT or DM-GREJECT

Short Description: The DM-GTX REQUEST PDU shall be the message sent to the gateway as a request for a changeover of the DM channel for a circuit mode transaction.

Table 13: DM-GTX REQUEST PDU contents

Information element	Length	Type	Remark
Message dependent elements			
Gateway message subtype	5	M	Value 00100 ₂ indicates DM-GTX REQUEST PDU
Type of DM-GTX REQUEST	1	M	
Reserved	3	M	Default value = 000 ₂
Circuit mode type	4	M	
Reserved	4	M	Default value = 0000 ₂
Priority level	2	M	
DM-SDU elements			
End-to-end encryption flag	1	M	
Call type flag	1	M	
Reserved	2	M	Default value = 00 ₂
Calling party TSI flag	1	M	
Calling party TSI	48	C	Included if calling party TSI flag = 1

14.5.6 DM-GTX ACCEPT

Message Name: DM-GTX ACCEPT

Response to: DM-GTX REQUEST

Response Expected: -

Short Description: The DM-GTX ACCEPT PDU shall be the message sent by the gateway to accept a changeover request for a circuit mode transaction.

Table 14: DM-GTX ACCEPT PDU contents

Information element	Length	Type	Remark
Message dependent elements			
Gateway message subtype	5	M	Value 00101 ₂ indicates DM-GTX ACCEPT PDU
Power class	3	M	
Power control flag	1	M	
Reserved	1	M	Default value = 0 ₂
Gateway encryption state on SwMI	1	M	See EN 300 396-6 [6], clause 6.3 for element coding
Circuit mode type	4	M	
Reserved	4	M	Default value = 0000 ₂
DM-SDU elements			
End-to-end encryption flag	1	M	
Call type flag	1	M	
Reserved	4	M	Default value = 0000 ₂

14.5.7 DM-GPREEMPT

Message Name: DM-GPREEMPT

Response to: -

Response Expected: DM-GPRE ACCEPT or DM-GREJECT

Short Description: The DM-GPREEMPT PDU shall be the message sent to the gateway to request pre-emption of the DM channel for a circuit mode transaction within the ongoing call.

Table 15: DM-GPREEMPT PDU contents

Information element	Length	Type	Remark
Message dependent elements			
Gateway message subtype	5	M	Value 00110 ₂ indicates DM-GPREEMPT PDU
Perceived channel state	2	M	
Reserved	2	M	Default value = 00 ₂
Circuit mode type	4	M	
Reserved	4	M	Default value = 0000 ₂
Priority level	2	M	
DM-SDU elements			
End-to-end encryption flag	1	M	
Call type flag	1	M	
Reserved	2	M	Default value = 00 ₂
Calling party TSI flag	1	M	
Calling party TSI	48	C	Included if calling party TSI flag = 1

14.5.8 DM-GPRE ACCEPT

Message Name: DM-GPRE ACCEPT

Response to: DM-GPREEMPT

Response Expected: -

Short Description: The DM-GPRE ACCEPT PDU shall be the message sent by the gateway to accept a pre-emption request for a circuit mode transaction within the ongoing call.

Table 16: DM-GPRE ACCEPT PDU contents

Information element	Length	Type	Remark
Message dependent elements			
Gateway message subtype	5	M	Value 00111 ₂ indicates DM-GPRE ACCEPT PDU
Power class	3	M	
Power control flag	1	M	
Reserved	1	M	Default value = 0 ₂
Gateway encryption state on SwMI	1	M	See EN 300 396-6 [6], clause 6.3 for element coding
Circuit mode type	4	M	
Reserved	4	M	Default value = 0000 ₂
DM-SDU elements			
End-to-end encryption flag	1	M	
Call type flag	1	M	
Reserved	4	M	Default value = 0000 ₂

14.5.9 DM-GREJECT

Message Name: DM-GREJECT

Response to: DM-GPREEMPT or DM-GTX REQUEST

Response Expected: -

Short Description: The DM-GREJECT PDU shall be the message sent by the gateway addressed either to the requester for pre-emption of the DM channel or to a DM-MS requesting changeover rejecting their request.

Table 17: DM-GREJECT PDU contents

Information element	Length	Type	Remark
Message dependent elements			
Gateway message subtype	5	M	Value 01000 ₂ indicates DM-GREJECT PDU
DM-SDU elements			
Gateway reject cause	4	M	

14.5.10 DM-GREGISTER REQUEST

Message Name: DM-GREGISTER REQUEST

Response to: -

Response Expected: DM-GREGISTER ACCEPT or DM-GREGISTER REJECT

Short Description: The DM-GREGISTER REQUEST PDU shall be the message sent to the gateway when a DM-MS wishes to register.

Table 18: DM-GREGISTER REQUEST PDU contents

Information element	Length	Type	Remark
Message dependent elements			
Gateway message subtype	5	M	Value 01001 ₂ indicates DM-GREGISTER REQUEST PDU
Type of registration request	1	M	
Registration transaction time remaining	4	M	
Reserved	2	M	
DM-SDU elements			
Calling party TSI flag	1	M	
Calling party TSI	48	C	Included if calling party TSI flag = 1
Serviced GSSI flag	1	M	Cannot be set to 1 if calling party TSI flag = 1 (note)
Serviced GSSI	24	C	Included if serviced GSSI flag = 1

NOTE: The serviced GSSI element cannot be included if the DM-MS needs to provide its ITSI in the layer 3 PDU i.e. if it is using a pseudo address at layer 2.

14.5.11 DM-GREGISTER ACCEPT

Message Name: DM-GREGISTER ACCEPT

Response to: DM-GREGISTER REQUEST

Response Expected: -

Short Description: The DM-GREGISTER ACCEPT PDU shall be the message sent by the gateway to accept a registration request from a DM-MS.

Table 19: DM-GREGISTER ACCEPT PDU contents

Information element	Length	Type	Remark
Message dependent elements			
Gateway message subtype	5	M	Value 01010 ₂ indicates DM-GREGISTER ACCEPT PDU
Type of registration request	1	M	
Reserved	2	M	
DM-SDU elements			
Registration label	4	M	
Reserved	4	M	

14.5.12 DM-GREGISTER REJECT

Message Name: DM-GREGISTER REJECT

Response to: DM-GREGISTER REQUEST

Response Expected: -

Short Description: The DM-GREGISTER REJECT PDU shall be the message sent by the gateway to reject the registration request.

Table 20: DM-GREGISTER REJECT PDU contents

Information element	Length	Type	Remark
Message dependent elements			
Gateway message subtype	5	M	Value 01011 ₂ indicates DM-GREGISTER REJECT PDU
Type of registration request	1	M	
Reserved	2	M	
DM-SDU elements			
Registration label	4	M	
Registration reject cause	4	M	

14.5.13 DM-GREGISTER CANCEL

Message Name: DM-GREGISTER CANCEL

Response to: -

Response Expected: DM-GCANCEL ACK

Short Description: The DM-GREGISTER CANCEL PDU shall be the message sent by the gateway to cancel a previously accepted registration.

Table 21: DM-GREGISTER CANCEL PDU contents

Information element	Length	Type	Remark
Message dependent elements			
Gateway message subtype	5	M	Value 01100 ₂ indicates DM-GREGISTER CANCEL PDU
Registration transaction time remaining	4	M	
Reserved	2	M	
DM-SDU elements			
Registration label	4	M	
Registration reject cause	4	M	

14.5.14 DM-GCANCEL ACK

Message Name: DM-GCANCEL ACK

Response to: DM-GREGISTER CANCEL

Response Expected: -

Short Description: The DM-GCANCEL ACK PDU shall be the message sent by the DM-MS as an acknowledgement to the cancellation of an existing registration.

Table 22: DM-GCANCEL ACK PDU contents

Information element	Length	Type	Remark
Message dependent elements			
Gateway message subtype	5	M	Value 01101 ₂ indicates DM-GCANCEL ACK PDU
Reserved	2	M	
DM-SDU elements			
Registration label	4	M	

14.6 Message dependent elements coding

EN 300 396-3 [3], clause 9.6 shall apply with the following differences:

- i) For operation with a DM-REP/GATE, when a master DM-MS transmits DM-SETUP and DM-OCCUPIED messages on the master link, it shall set the "power class" element to its own power level and shall set the "power control flag" to 0.

When the DM-REP/GATE re-transmits the master DM-MS's DM-SETUP and DM-OCCUPIED messages on the slave link, it shall set the "power class" element to its own power level and shall set the "power control flag" to enable or disable DM-MS power control procedures as appropriate. As in EN 300 396-3 [3], clause 9.6.9, the "power control flag" indicates whether or not power control by slave and idle DM-MSs is permitted. When operating with a DM-REP/GATE, a master DM-MS also may perform power control if permitted by the DM-REP/GATE's most recent setting of the "power control flag".

When operating with a DM-GATE, a master DM-MS in an individual call may perform power control if permitted by the DM-GATE's most recent setting of the "power control flag".

- ii) The perceived channel state element may take an additional value as shown in table 23. If a pre-empting MS indicates that it regards the DM channel as being in a registration phase then it expects the response to its pre-emption request to appear in the DSB.

Table 23: Perceived channel state element

Information element	Length	Value	Remark
Perceived channel state	2	00 ₂ to 10 ₂	As defined in EN 300 396-3 [3]
		11 ₂	Registration phase

- iii) The type of pre-emption element may take additional values as shown in table 24. These additional values are sent only by the gateway.

Table 24: Type of pre-emption element

Information element	Length	Value	Remark
Type of pre-emption	4	0000 ₂ to 0010 ₂	As defined in EN 300 396-3 [3]
		0011 ₂	Pre-emption for TMO transaction in ongoing call (i.e. TMO INTERRUPT procedure)
		0100 ₂	TMO WAIT procedure
		0101 ₂	TMO temporary break
		0110 ₂	TMO slot numbering or slot timing change
		0111 ₂	TMO call transaction timer expired
		1000 ₂	Pre-emptive use of resource by gateway
others	Reserved		

- iv) The present document does not support dual watch operation by a DM-MS operating with a gateway. Therefore, for operation with a gateway, the "dual watch synchronization flag" should be set to 0.
- v) In the case of a call through a DM-REP/GATE (i.e. a call with element "communication type" set to 11₂ and element "A/B channel usage" set to 00₂), the two-frequency call flag indicates whether the master DM-MS assumes that this is a type 1A or type 1B call.

NOTE: If the "two-frequency call flag" is set to 1 then a DM-MS receiving on the downlink needs to know the duplex spacing (and whether f_1 is above or below f_2) before it can transmit on the uplink, either by receiving the presence signal or by prior arrangement.

Similarly, if a DM-MS receives the message on the uplink (i.e. if it receives the message as sent by the master DM-MS on the master link), it needs to know the duplex spacing (and whether f_1 is above or below f_2) in order to be able to identify the frequency of the downlink.

The following clauses shall also apply.

14.6.1 Gateway message subtype

The gateway message subtype element indicates the type of gateway-specific layer 3 PDU sent over the air interface. The interpretation of subsequent elements in the PDU is dependent on the value of the gateway message subtype element.

Information element	Length	Value	Remark
Gateway message subtype	5	00000 ₂	DM-GSETUP
		00001 ₂	DM-GCONNECT
		00010 ₂	DM-GACK
		00011 ₂	DM-GRELEASE
		00100 ₂	DM-GTX REQUEST
		00101 ₂	DM-GTX ACCEPT
		00110 ₂	DM-GPREEMPT
		00111 ₂	DM-GPRE ACCEPT
		01000 ₂	DM-GREJECT
		01001 ₂	DM-GREGISTER REQUEST
		01010 ₂	DM-GREGISTER ACCEPT
		01011 ₂	DM-GREGISTER REJECT
		01100 ₂	DM-GREGISTER CANCEL
		01101 ₂	DM-GCANCEL ACK
others	Reserved		

14.6.2 Registration transaction time remaining

The registration transaction time remaining element is used to indicate the current estimate of the DM channel occupation time during a registration transaction.

Information element	Length	Value	Remark
Registration transaction time remaining	4	0000 ₂	End of registration transaction
		0001 ₂	1 frame remaining
		0010 ₂	2 frames remaining
		0011 ₂	3 frames remaining
		0100 ₂	4 frames remaining
		...etc.	...etc.
		1111 ₂	15 frames remaining

14.6.3 Reservation announced

The reservation announced element in the DM-GACK PDU indicates whether the message acts also as the equivalent of a channel reservation message e.g. containing reservation time remaining and random access parameters.

Information element	Length	Value	Remark
Reservation announced	1	0	Reservation parameters not included
		1	Reservation parameters included

14.6.4 Type of DM-GTX REQUEST

The type of DM-GTX REQUEST element indicates whether the message follows successful pre-emption of a DM-MS.

Information element	Length	Value	Remark
Type of DM-GTX REQUEST	1	0	Message sent by normal random access
		1	Message follows successful pre-emption of a DM-MS

14.6.5 Type of registration request

The type of registration request element indicates whether the registration request is sent during a registration phase or whether it is sent outside a registration phase.

Information element	Length	Value	Remark
Type of registration request	1	0	Request sent during registration phase i.e. a solicited registration request
		1	Request sent outside registration phase i.e. an unsolicited registration request

14.7 DM-SDU elements coding

EN 300 396-3 [3], clause 9.7 shall apply with the following differences:

- i) The additional address type(s) element may take additional values as shown in table 25.

Table 25: Additional address type(s) element

Information element	Length	Value	Remark
Additional address type(s)	4	0000 ₂ and 0001 ₂	As defined in EN 300 396-3 [3]
		0010 ₂	Area selection
		0011 ₂	Area selection + calling party TSI
		0100 ₂	External subscriber number
		0101 ₂	External subscriber number + calling party TSI
		others	Reserved

- ii) The cease cause element may take additional values as shown in table 26.

Table 26: Cease cause element

Information element	Length	Value	Remark
Cease cause	4	0000 ₂ to 0011 ₂	As defined in EN 300 396-3 [3]
		0100 ₂	Interruption for TMO transaction
		0101 ₂	TMO WAIT
		0110 ₂	TMO temporary break
		0111 ₂	TMO slot numbering or slot timing change
		1000 ₂	TMO call transaction timer expired
others	Reserved		

- iii) The information type element may take additional values as shown in table 27.

Table 27: Information type element

Information element	Length	Value	Remark
Information type	3	000 ₂	Calling party TSI (used for TPNI) (i.e. as defined in EN 300 396-3 [3])
		001 ₂	External subscriber number
		010 ₂	TSI and external subscriber number
		others	Reserved

- iv) The reject cause element may take additional values as shown in table 28.

Table 28: Reject cause element

Information element	Length	Value	Remark
Reject cause	4	0000 ₂ to 0011 ₂	As defined in EN 300 396-3 [3]
		0100 ₂	Called gateway does not support short data
		0101 ₂	Request rejected by gateway
		others	Reserved

- v) The release cause element may take additional values as shown in table 29.

Table 29: Release cause element

Information element	Length	Value	Remark
Release cause	4	0000 ₂ to 0110 ₂	As defined in EN 300 396-3 [3]
		0111 ₂	Used in EN 300 396-4 [4]
		1000 ₂	Link to gateway failed
		1001 ₂	Call rejected by gateway
		1010 ₂	Call rejected by SwMI
		1011 ₂	TMO call set-up failure
		1100 ₂	TMO resource lost or call timer expired
		1101 ₂	Transmit authorization lost
		1110 ₂	Called party is under the same DM-GATE as the calling party
		1111 ₂	The reason for the release is given in the release cause extension element

- vi) The release cause extension element may take additional values as shown in table 30.

Table 30: Release cause extension element

Information element	Length	Value	Remark
Release cause extension	5	00000 ₂	As defined in EN 300 396-3 [3]
		00001 ₂	Security parameter mismatch
		00010 ₂	Called party busy
		00011 ₂	Unknown TETRA identity
		00100 ₂	Unknown external subscriber identity
		00101 ₂	Called party does not support encryption
		00110 ₂	Called party requires encryption
		others	Reserved

The following clauses shall also apply.

14.7.1 Area selection

The area selection element is used to indicate to the SwMI the distribution of the call.

Information element	Length	Value	Remark
Area selection	4	0000 ₂	Area not defined using this information element
		0001 ₂	Area 1
		0010 ₂	Area 2
		etc....	etc....
		1110 ₂	Area 14
		1111 ₂	All areas this system

14.7.2 Called party address type flag

The called party address type flag is used to indicate whether the called party SSI or TSI is provided in the PDU. When only the called party SSI is provided then the MNI from the layer 2 PDU applies.

Information element	Length	Value	Remark
Called party address type flag	1	0	SSI provided
		1	TSI provided

14.7.3 Called party MNI

The called party MNI element provides the Mobile Network Identity of the called party. The MNI element shall be sent MSB first.

14.7.4 Called party SSI

The called party SSI element identifies the intended recipient(s) of the call. It can be either an Individual SSI (ISSI) or a Group SSI (GSSI).

14.7.5 Calling party TSI flag

The calling party TSI flag is used to indicate whether the address of the requesting DM-MS is included within the layer 3 PDU.

Information element	Length	Value	Remark
Calling party TSI flag	1	0	Calling party TSI not included
		1	Calling party TSI included

14.7.6 External subscriber number

The purpose of the external subscriber number element is to allow the transfer of an external subscriber number. The external subscriber number can consist of n digits where n shall be less than or equal to 24.

Information element	Length	Value	Remark
Number of digits n	5		Indicates the number of following digits
External subscriber number digit number 1 to n	n x 4	0000 ₂	Digit "0"
		0001 ₂	Digit "1"
		0010 ₂	Digit "2"
		0011 ₂	Digit "3"
		0100 ₂	Digit "4"
		0101 ₂	Digit "5"
		0110 ₂	Digit "6"
		0111 ₂	Digit "7"
		1000 ₂	Digit "8"
		1001 ₂	Digit "9"
		1010 ₂	Digit "*"
		1011 ₂	Digit "#"
		1100 ₂	Digit "+"
		1101 ₂	Reserved
		1110 ₂	Reserved
1111 ₂	Reserved		

14.7.7 Gateway reject cause

The gateway reject cause element is used to indicate the reason why a gateway-specific changeover or pre-emption request is being denied.

Information element	Length	Value	Remark
Gateway reject cause	4	0000 ₂	Cause not defined or unknown
		0001 ₂	Request invalid
		0010 ₂	Request rejected by gateway
		0011 ₂	Request rejected by SwMI
		0100 ₂	TMO transmission failure
		others	Reserved

14.7.8 Gateway release cause

The gateway release cause element is used to indicate the reason why the gateway can no longer support the call.

Information element	Length	Value	Remark
Gateway release cause	4	0000 ₂	Cause not defined or unknown
		0001 ₂	TMO resource lost
		0010 ₂	TMO call timer expired
		others	Reserved

14.7.9 Registration label

The registration label element is used to label the registrations that are accepted by the gateway. These registrations are valid only when the registration label for the registrations matches that being broadcast by the gateway in the gateway presence signal.

Information element	Length	Value	Remark
Registration label	4	0000 ₂	Registration label 0
		0001 ₂	Registration label 1
		0010 ₂	Registration label 2
		0011 ₂	Registration label 3
		etc....	etc....
		1111 ₂	Registration label 15

14.7.10 Registration reject cause

The registration reject cause element is used to indicate the reason why a registration request has been rejected or cancelled.

Information element	Length	Value	Remark
Registration reject cause	4	0000 ₂	Cause not defined or unknown
		0001 ₂	ITSI not known to gateway
		0010 ₂	No response from SwMI
		0011 ₂	Attachment rejected by SwMI
		0100 ₂	Request rejected by gateway
		0101 ₂	Gateway cannot support requested group
		others	Reserved

14.7.11 Request label

The request label element is used to label a DM-GSETUP request. This guards against any possible signalling ambiguity.

Information element	Length	Value	Remark
Request label	4	0000 ₂	Request label 0
		0001 ₂	Request label 1
		0010 ₂	Request label 2
		etc.	etc....
		1111 ₂	Request label 15

14.7.12 Serviced GSSI

The purpose of the serviced GSSI element is to indicate to the gateway a GSSI that the requesting DM-MS wishes to use.

14.7.13 Serviced GSSI flag

The purpose of the serviced GSSI flag is to indicate to the gateway whether the requesting DM-MS has supplied a GSSI that it wishes to use.

Information element	Length	Value	Remark
Serviced GSSI flag	1	0	GSSI not supplied
		1	GSSI supplied

14.7.14 Type of DM-GACK

The type of DM-GACK element is used to indicate whether the received DM-MS message was fully received.

NOTE: Incomplete reception can apply only to a DM-GSETUP message.

Information element	Length	Value	Remark
Type of DM-GACK	2	00 ₂	Message fully received
		01 ₂	Message not fully received
		10 ₂	Reserved
		11 ₂	Reserved

14.7.15 Value of DM-MS waiting timer

The value of DM-MS waiting timer element is used to indicate the value that the DM-MS should use for timer DT302, DT308 or DT309.

Information element	Length	Value	Remark
Value of DM-MS waiting timer	3	000 ₂	Use predefined value of timer (i.e. configured value or default value)
		001 ₂	1 second
		010 ₂	2 seconds
		011 ₂	5 seconds
		100 ₂	10 seconds
		101 ₂	20 seconds
		110 ₂	30 seconds
		111 ₂	60 seconds

Annex A (normative): DM timers and constants in DM-MS and gateway

This annex lists the timers and constants in a DM-MS when operating with a DM-GATE or DM-REP/GATE.

Where indicated, a value should be chosen by the MS designer from within the specified range. For other timers and constants, a default value is specified and the value of these timers and constants shall be configurable within the DM-MS.

This annex also lists the timers and constants in the gateway. The values of these timers and constants shall be configurable within the gateway or, if specified, chosen by the gateway designer. Suggested default values are given.

A.1 Layer 3 timers in DM-MS

DT301	Time-out waiting for response to DM-GSETUP. Value to be chosen by MS designer. Suggested value = 1 second.
DT302	Time-out waiting for DM-GCONNECT after receiving DM-GACK. Default value = 30 seconds if value not supplied in DM-GACK.
DT307	Time-out waiting for response to DM-CONNECT. Value to be chosen by MS designer. Suggested value of DT307 = 32 seconds.
DT308	Time-out waiting for DM-GPRE ACCEPT after receiving DM-GACK. Default value = 30 seconds if value not supplied in DM-GACK.
DT309	Time-out waiting for DM-GTX ACCEPT after receiving DM-GACK. Default value = 10 seconds if value not supplied in DM-GACK.
DT311	Call transaction timer. Value to be chosen by MS designer or given by configuration. Suggested maximum value = 300 seconds.
DT314	Time-out for reporting SDS failure after sending DM-PRE ACCEPT. Value to be chosen by MS designer. Suggested value = 500 ms.
DT316	Time-out waiting for response to DM-SDS DATA. Value to be chosen by MS designer. Suggested value = 400 ms for operation with a DM-GATE. Suggested value = 600 ms for operation with a DM-REP/GATE.
DT326	Time-out waiting for response to unsolicited registration. Value to be chosen by MS designer. Suggested value = 250 ms for operation with a DM-GATE. Suggested value = 500 ms for operation with a DM-REP/GATE.

A.2 Layer 3 constants in DM-MS

DN301	Maximum number of attempts to send DM-GSETUP if no response received. MS designer choice from the range 1 to 3.
DN302	Maximum number of attempts to send DM-GSETUP after receiving DM-GACK. MS designer choice from the range 1 to 3.

DN314	Number of transmissions of DM-SDS UDATA. Value may be chosen by MS designer (or may be message dependent) from the range 1 to 6.
DN315	Maximum number of attempts to send DM-SDS DATA if negative response received. MS designer choice from the range 2 to 6.
DN316	Maximum number of attempts to send DM-SDS DATA if no response received. MS designer choice from the range 1 to 4.
DN326	Maximum number of attempts to send unsolicited registration if no response received. MS designer choice from the range 1 to 4.

A.3 Layer 2 timers in DM-MS

DT205	Time when randomization is required for call set-up after channel becomes free. Default value = 18 frame durations.
DT206	Time when longer randomization is required for call set-up after new call pre-emption acceptance. Value to be chosen by MS designer. Default value = 9 frame durations.
DT207	Inactivity time-out for idle DM-MS in channel occupation or reservation. Default value = 90 frame durations.
DT208	Time-out waiting for reservation signalling after short data transaction within ongoing call. Default value = 90 frame durations.
DT210	Time allowed by master for response to DM-SDS DATA before sending DM-PRE ACCEPT. Default value = 4 frame durations. Minimum value 2 frame durations, maximum value = 5 frame durations. Should be at least one more frame duration than DN270 in any gateway the DM-MS can send DM-SDS DATA to.
DT211	Time-out waiting for random access response (circuit mode occupation or reservation). Default value = 3 frame durations. Minimum value = 3 frame durations.
DT212	Time-out waiting for random access response (short data occupation). Default value = 7 frame durations. Minimum value = 7 frame durations.
DT213	Random access time-out for non-emergency message. MS designer choice from the range 2 to 60 multiframe durations.
DT214	Validity time-out when attempting random access. Default value = 36 frame durations.
DT215	Random access time-out for emergency message. Value to be chosen by MS designer from the range 2 to 60 multiframe durations or given by configuration.
DT221	Inactivity time-out for slave DM-MS in channel occupation or reservation. Default value = 90 frame durations.
DT226	Inactivity time-out on link from gateway for master DM-MS in circuit mode occupation. Default value = 90 frame durations.
DT234	Time-out for sending an unsolicited registration request outside a registration phase. Value to be chosen by MS designer or given by configuration.

DT236	Time-out waiting for response to registration request during registration phase. Default value = 3 frame durations.
DT237	Registration access time-out. MS designer choice from the range 5 to 60 multiframe durations.
DT238	Time-out waiting for response to pre-emption request during registration phase. Default value = 3 frame durations.

A.4 Layer 2 constants in DM-MS

DN204	Minimum randomization for call set-up after channel becomes free. Default value = 1.
DN205	Maximum randomization for call set-up after channel becomes free. Default value = 8.
DN206	Minimum randomization for non-immediate retransmission of call set-up. Default value = 8.
DN207	Maximum randomization for non-immediate retransmission of call set-up. Default value = 12.
DN210	Maximum number of frames containing slave's response DSB. Default value = 3. Minimum value 1, maximum value 4.
DN212	Number of SCH/F slots of DM-SDS DATA that may be sent before pre-emption acceptance. Default value = 2. Maximum value = 6 – DT210 (expressed in frames).
DN213	Maximum number of non-emergency random access transmissions. Default value = 8.
DN215	Maximum number of emergency random access transmissions. Default value = 16.
DN232	Number of frames in which a master DM-MS expects the DM-REP/GATE to transmit its DM-SETUP message on the slave link. Minimum value = 2. Maximum value = 4. Default value = 2 if value not received in gateway presence signal.
DN233	Number of frames in which a master DM-MS expects the DM-REP/GATE to transmit the DSB heading a DM-SDS UDATA or DM-SDS DATA message (or unsolicited registration) on the slave link. Minimum value = 2. Maximum value = 4. Default value = 2 if value not received in gateway presence signal.
NOTE:	DN232 and DN233 apply to both DM-MS and DM-REP/GATE. For correct operation of the short data protocol and the air interface encryption methods, it is essential that the master DM-MS uses the same values of DN232 and DN233 as the DM-REP/GATE, see notes in clauses 8.5.4.1 and 8.6.3.1.
DN235	Minimum randomization for unsolicited registration request after channel becomes free. Default value = 32.
DN236	Maximum randomization for unsolicited registration request after channel becomes free. Default value = 40.

DN237	Minimum randomization for retransmission of unsolicited registration request. Default value = 8.
DN238	Maximum randomization for retransmission of unsolicited registration request. Default value = 12.
DN239	Maximum number of registration access transmissions. Default value = 8.

A.5 Maximum number of frame transmissions by DM-MAC

The following table shows the minimum and maximum number of frames in which each message may be sent by the DM-MAC in the source DM-MS when using the frame countdown mechanism.

Table A.1: Number of frame transmissions by DM-MAC

Message type	Minimum to maximum number of frames in which message may be sent
DM-SETUP	2 to 4 for new group call set-up through DM-GATE; 1 to 4 for continuation of ongoing call through DM-GATE
DM-CONNECT	1 to DN210
DM-DISCONNECT	1 to DN210
DM-TX CEASED	2 to 4
DM-RELEASE	2 to 4
DM-PRE ACCEPT	2 to 4
DM-REJECT	1 to 4
DM-SDS DATA (DSB)	2 to 4 for new call set-up, for fragmented data 2 to 4 for new call set-up, for non-fragmented data 1 to 4 for continuation of ongoing call
DM-SDS UDATA (DSB)	2 to 4 for new call set-up 1 to 4 for continuation of ongoing call
DM-SDS ACK (DSB)	1 to DN210
DM-GSETUP	2 to 4
DM-GTX REQUEST	2 to 4
DM-GREGISTER REQUEST	2 to 4
DM-GCANCEL ACK	1 to DN210

NOTE 1: The numbers of frames in which each message is sent may be set by the MS designer, or otherwise the MS designer may choose to allow some or all of the values to be configurable.

NOTE 2: The entry for DM-GTX REQUEST applies only when the message is sent after pre-emption of another DM-MS. At other times the DM-GTX REQUEST is sent using the random access protocol in which case the frame countdown mechanism is not used.

NOTE 3: The entry for DM-GREGISTER REQUEST applies only to an unsolicited registration. When the message is sent during a registration phase, it is sent using the registration access protocol in which case the frame countdown mechanism is not used.

A.6 Layer 3 DM timers in gateway

DT361	Time-out waiting for response to DM-SETUP PRES. Value to be chosen by gateway designer. Suggested value = 250 ms.
-------	---

DT363	Time-out waiting for response to DM-GCONNECT. Value to be chosen by gateway designer. Suggested value = 700 ms.
DT365	Time-out waiting for response to DM-GPRE ACCEPT sent during occupation. Value to be chosen by gateway designer. Suggested value = 700 ms.
DT366	Time-out waiting for response to DM-PRE ACCEPT sent during occupation. Default value = 3 seconds.
DT367	Time-out waiting for response to DM-GTX ACCEPT (or DM-GPRE ACCEPT sent in reservation). Value to be chosen by gateway designer. Suggested value = 700 ms.
DT368	Time-out waiting for response to DM-TX ACCEPT (or DM-PRE ACCEPT sent in reservation). Default value = 3 seconds.
DT369	Time-out waiting for response to DM-SDS DATA. Value to be chosen by gateway designer. Suggested value = 400 ms.
DT375	Time-out waiting for response to DM-GREGISTER CANCEL. Value to be chosen by gateway designer. Suggested value = 250 ms.

A.7 Layer 3 DM constants in gateway

DN361	Maximum number of attempts to send DM-SETUP PRES if no response received. Gateway designer choice from the range 1 to 6.
DN367	Number of transmissions of DM-SDS UDATA. Value may be chosen by gateway designer (or may be message dependent) from the range 1 to 6.
DN368	Maximum number of attempts to send DM-SDS DATA if negative response received. Gateway designer choice from the range 2 to 6.
DN369	Maximum number of attempts to send DM-SDS DATA if no response received. Gateway designer choice from the range 1 to 6.
DN375	Maximum number of attempts to send DM-GREGISTER CANCEL. Gateway designer choice from the range 1 to 6.

A.8 Layer 2 DM timers in gateway

DT263	Minimum interval between transmissions of gateway presence signal on a free carrier. Value to be chosen by gateway designer or given by configuration.
DT264	Maximum interval between transmissions of gateway presence signal on a free carrier. Maximum value = 60 multiframe durations. Value to be chosen by gateway designer or given by configuration. A value of 0 indicates that the gateway does not transmit the presence signal periodically on a free carrier.
DT265	Time when randomization is required for transmission by gateway after channel becomes free. Default value = 18 frame durations.

DT266	Inactivity time-out for slave gateway in channel occupation. Default value = 90 frame durations.
DT267	Inactivity time-out for idle gateway in channel occupation or reservation. Default value = 108 frame durations.
DT268	Time-out waiting for DM-GTX REQUEST after DM-MS pre-emption of master DM-MS. Default value = 6 frame durations.
DT269	Time-out waiting for short data DSB after DM-MS pre-emption of master DM-MS. Default value = 54 frame durations.
DT270	Time allowed by gateway for response to DM-SDS DATA before accepting pre-emption. Default value = 4 frame durations. Minimum value 2 frame durations, maximum value = 5 frame durations. Should be at least one more frame duration than DN210 in any slave DM-MS the gateway can send DM-SDS DATA to.
DT273	Gateway access time-out. Gateway designer choice from the range 2 to 60 multiframe durations.
DT275	Time-out waiting for channel to become free to send a registration cancellation message. Value to be chosen by gateway designer or given by configuration.
DT276	Time when longer randomization is required for transmission after new call pre-emption acceptance. Value to be chosen by gateway designer. Minimum value = 9 frame durations.

A.9 Layer 2 DM constants in gateway

DN232	Number of frames in which a DM-REP/GATE transmits a DM-MS's DM-SETUP message on the slave link. Minimum value = 2. Maximum value = 4. Default value = 2.
DN233	Number of frames in which a DM-REP/GATE transmits the DSB heading a DM-MS's DM-SDS UDATA or DM-SDS DATA message (or unsolicited registration) on the slave link. Minimum value = 2. Maximum value = 4. Default value = 2.
NOTE:	DN232 and DN233 apply to both DM-REP/GATE and DM-MS. For correct operation of the short data protocol and the air interface encryption methods, it is essential that the DM-REP/GATE uses the same values of DN232 and DN233 as the master DM-MS, see notes in clauses 8.5.4.1 and 8.6.3.1.
DN263	Number of frames in which the gateway transmits the free-channel presence signal. Gateway designer choice from the range 2 to 4.
DN264	Minimum randomization by gateway for transmission after channel becomes free. Default value = 1.
DN265	Maximum randomization by gateway for transmission after channel becomes free. Default value = 8.
DN266	Minimum randomization by gateway for non-immediate retransmission of call set-up. Default value = 8.

DN267	Maximum randomization by gateway for non-immediate retransmission of call set-up. Default value = 12.
DN270	Maximum number of frames containing slave gateway's response DSB. Default value = 3. Minimum value 1, maximum value 4
DN272	Number of SCH/F slots of DM-SDS DATA that may be sent before pre-emption acceptance. Default value = 2. Maximum value = 6 – DT270 (expressed in frames).
DN274	Minimum randomization by gateway for initiation of registration phase. Default value = 32.
DN275	Maximum randomization by gateway for initiation of registration phase. Default value = 40.
DN276	Minimum randomization by gateway for sending a registration cancellation after channel becomes free. Default value = 32.
DN277	Maximum randomization by gateway for sending a registration cancellation after channel becomes free. Default value = 40.
DN278	Minimum randomization by gateway for retransmission of registration cancellation. Default value = 8.
DN279	Maximum randomization by gateway for retransmission of registration cancellation. Default value = 12.

A.10 Maximum number of DM frame transmissions by gateway layer 2

Table A.2 shows the minimum and maximum number of frames in which each message may be sent by the gateway layer 2 when using the frame countdown mechanism.

Table A.2: Number of frame transmissions by gateway layer 2

Message type	Minimum to maximum number of frames in which message may be sent
DM-SETUP	2 to 4 for new call set-up 2 to 4 for continuation of ongoing call
DM-SETUP PRES	2 to 4 for new call set-up 2 to 4 for continuation of ongoing call
DM-CONNECT ACK	1 to 4
DM-TX CEASED	2 to 4
DM-RELEASE	2 to 4
DM-TX ACCEPT	2 to 4
DM-PRE ACCEPT	2 to 4
DM-REJECT	1 to 4
DM-TIMING ACK	2 to 4
DM-SDS DATA (DSB)	2 to 4 for new call set-up 2 to 4 for continuation of ongoing call
DM-SDS UDATA (DSB)	2 to 4 for new call set-up 2 to 4 for continuation of ongoing call
DM-SDS ACK (DSB)	1 to DN270
DM-GACK	1 to 4
DM-GCONNECT	2 to 4
DM-GTX ACCEPT	2 to 4
DM-GPRE ACCEPT	2 to 4
DM-GREJECT	1 to 4
DM-GREGISTER ACCEPT	1 to 4 during registration phase 1 to DN270 outside registration phase
DM-GREGISTER REJECT	1 to 4 during registration phase 1 to DN270 outside registration phase
DM-GREGISTER CANCEL	2 to 4

NOTE: The numbers of frames in which each message is sent may be set by the gateway designer, or otherwise the gateway designer may choose to allow some or all of the values to be configurable.

Annex B (normative): TMO elements required for DM gateway operation

This annex defines the TMO PDU elements that relate to DM gateway operation and are not contained in EN 300 392-2 [5].

B.1 Usage of DM-MS address element

When a gateway sends or receives a TMO message on behalf of an individual DM-MS, it uses its own individual address as the TMO layer 2 address. The address of the DM-MS may be included within the layer 3 PDU as a type 3 element. This type 3 element indicates the source DM-MS when the gateway sends a message to the SwMI, or the destination DM-MS when the gateway receives a message from the SwMI.

The DM-MS address element may be included in appropriate call control and SDS PDUs when applicable.

NOTE 1: The "DM-MS address" element may be included when applicable in the following call control and SDS PDUs: D-CALL RESTORE, D-SDS DATA, D-STATUS, D-SETUP, D-TX CEASED, D-TX CONTINUE, D-TX GRANTED, D-TX INTERRUPT, D-TX WAIT, U-CALL RESTORE, U-STATUS, U-SDS DATA, U-SETUP, U-TX CEASED and U-TX DEMAND.

NOTE 2: The "DM-MS address" element need not be included when it can be deduced from the context. For example, it need not be included when U-TX CEASED is sent to terminate a traffic transmission but may be needed when U-TX CEASED is sent to withdraw a previous transmit request.

NOTE 3: The "DM-MS address" element may be included when the gateway has been accepted by the SwMI for gateway operation and has accepted this DM-MS address. Use of the "DM-MS address" element at other times may or may not be supported.

The type 3 element identifier value for the DM-MS address element is defined for call control and SDS PDUs in EN 300 392-2 [5], clause 14. The type 3/4 element identifier value for the "DM-MS address" information element is defined for MM PDUs in EN 300 392-2 [5], clause 16.

The "DM-MS address" information element is defined in clause B.3.1.

B.2 Encoding of D-MM STATUS and U-MM STATUS PDUs

A direct mode gateway MS requests to start, continue and stop operation as a DM gateway, and sends DM-MS addresses to the infrastructure, using TMO's U-MM STATUS PDU. The infrastructure uses the D-MM STATUS PDU e.g. when it responds and when it sends commands relating to DM gateway operation. The D-MM STATUS and U-MM STATUS PDU sub-PDUs relating to DM gateway operation shall be encoded as defined in clauses B.2.1 and B.2.2. The generic structure of the D-MM STATUS and U-MM STATUS PDUs is presented in EN 300 392-2 [5], clauses 16.9.2.5.1 and 16.9.3.5.1.

B.2.1 D-MM STATUS

B.2.1.1 D-ACCEPTANCE TO START DM GATEWAY OPERATION

The status downlink information element value "Acceptance to start DM gateway operation" indicates the D-ACCEPTANCE TO START DM GATEWAY OPERATION PDU and the D-MM STATUS PDU shall contain information elements as defined in table B.1.

Message:	D-ACCEPTANCE TO START DM GATEWAY OPERATION
Response to:	U-REQUEST TO START DM GATEWAY OPERATION
Response expected:	-
Short description:	<p>The infrastructure sends this message to the direct mode gateway MS to indicate that a request is accepted to start operation as a DM gateway. If the DM gateway sent a list of DM-MS addresses in the U-REQUEST TO START DM GATEWAY OPERATION PDU then the D-ACCEPTANCE TO START DM GATEWAY OPERATION PDU indicates whether those addresses are accepted:</p> <ul style="list-style-type: none"> - if the "number of DM-MS addresses" element = 0000₂, this indicates that the list of DM-MS addresses sent by the DM gateway is accepted in full; - if the "number of DM-MS addresses" element ≠ 0000₂, this indicates that the list of DM-MS addresses sent by the DM gateway is accepted except those in the attached list of DM-MS addresses.

NOTE 1: For an acceptance of a request to start operation as a DM gateway, SwMI designers should note the specification in clause 9.3.3.4.1, in the paragraph above note 4.

NOTE 2: SwMI designers should also note that a DM gateway will not always be able to receive in all the slots on the TMO control channel. As defined in clause 13 (and in amendments 10 and 11), there are some instances when the DM gateway may give precedence to DM procedures over TMO requirements to transmit and/or receive on the TM channel. Therefore, if a DM gateway does not respond to a TMO message, the SwMI should not assume that the DM gateway has left the TMO network unless the DM gateway fails to transmit or respond to TMO messages over a period of time.

Table B.1: D-ACCEPTANCE TO START DM GATEWAY OPERATION PDU contents

Information element	Length	Type	C/O/M	Remark
PDU type	4	1	M	
Status downlink	6	1	M	Refer to table B.25
Reserved	8	1	M	Default value = 00000000 ₂
Number of DM-MS addresses	4	1	M	Note 1
DM-MS address	Variable	1	C	Note 2
Proprietary		3	O	
NOTE 1: If "number of DM-MS addresses" ≠ 0000 ₂ , the following DM-MS addresses are not accepted.				
NOTE 2: Shall be repeated as indicated by the "number of DM-MS addresses" information element.				

B.2.1.2 D-REJECTION TO START DM GATEWAY OPERATION

The status downlink information element value "Rejection to start DM gateway operation" indicates the D-REJECTION TO START DM GATEWAY OPERATION PDU and the D-MM STATUS PDU shall contain information elements as defined in table B.2.

Message:	D-REJECTION TO START DM GATEWAY OPERATION
Response to:	U-REQUEST TO START DM GATEWAY OPERATION
Response expected:	-
Short description:	The infrastructure sends this message to the direct mode gateway MS to indicate that a request is rejected to start operation as a DM gateway.

Table B.2: D-REJECTION TO START DM GATEWAY OPERATION PDU contents

Information element	Length	Type	C/O/M	Remark
PDU type	4	1	M	
Status downlink	6	1	M	Refer to table B.25
Reserved	8	1	M	Default value = 00000000 ₂
Proprietary		3	O	

B.2.1.3 D-ACCEPTANCE TO CONTINUE DM GATEWAY OPERATION

The status downlink information element value "Acceptance to continue DM gateway operation" indicates the D-ACCEPTANCE TO CONTINUE DM GATEWAY OPERATION PDU and the D-MM STATUS PDU shall contain information elements as defined in table B.3.

- Message: D-ACCEPTANCE TO CONTINUE DM GATEWAY OPERATION
- Response to: U-REQUEST TO CONTINUE DM GATEWAY OPERATION
- Response expected: -
- Short description: The infrastructure sends this message to the direct mode gateway MS to indicate that a request is accepted to continue operation as a DM gateway. The "retained DM-MS address set" information element indicates whether the SwMI has retained the previous DM-MS address set for this DM gateway.

Table B.3: D-ACCEPTANCE TO CONTINUE DM GATEWAY OPERATION PDU contents

Information element	Length	Type	C/O/M	Remark
PDU type	4	1	M	
Status downlink	6	1	M	Refer to table B.25
Retained DM-MS address set	1	1	M	
Reserved	7	1	M	Default value = 00000000 ₂
Proprietary		3	O	

B.2.1.4 D-REJECTION TO CONTINUE DM GATEWAY OPERATION

The status downlink information element value "Rejection to continue DM gateway operation" indicates the D-REJECTION TO CONTINUE DM GATEWAY OPERATION PDU and the D-MM STATUS PDU shall contain information elements as defined in table B.4.

- Message: D-REJECTION TO CONTINUE DM GATEWAY OPERATION
- Response to: U-REQUEST TO CONTINUE DM GATEWAY OPERATION
- Response expected: -
- Short description: The infrastructure sends this message to the direct mode gateway MS to indicate that a request is rejected to continue operation as a DM gateway.

Table B.4: D-REJECTION TO CONTINUE DM GATEWAY OPERATION PDU contents

Information element	Length	Type	C/O/M	Remark
PDU type	4	1	M	
Status downlink	6	1	M	Refer to table B.25
Reserved	8	1	M	Default value = 00000000 ₂
Proprietary		3	O	

B.2.1.5 D-ACCEPTANCE TO STOP DM GATEWAY OPERATION

The status downlink information element value "Acceptance to stop DM gateway operation" indicates the D-ACCEPTANCE TO STOP DM GATEWAY OPERATION PDU and the D-MM STATUS PDU shall contain information elements as defined in table B.5.

Message:	D-ACCEPTANCE TO STOP DM GATEWAY OPERATION
Response to:	U-REQUEST TO STOP DM GATEWAY OPERATION
Response expected:	-
Short description:	The infrastructure sends this message to the direct mode gateway MS to indicate that a request is accepted to stop operation as a DM gateway.

Table B.5: D-ACCEPTANCE TO STOP DM GATEWAY OPERATION PDU contents

Information element	Length	Type	C/O/M	Remark
PDU type	4	1	M	
Status downlink	6	1	M	Refer to table B.25
Reserved	8	1	M	Default value = 00000000 ₂
Proprietary		3	O	

B.2.1.6 D-ACCEPTANCE OF DM-MS ADDRESSES

The status downlink information element value "Acceptance of DM-MS addresses" indicates the D-ACCEPTANCE OF DM-MS ADDRESSES PDU and the D-MM STATUS PDU shall contain information elements as defined in table B.6.

Message:	D-ACCEPTANCE OF DM-MS ADDRESSES
Response to:	U-REQUEST TO ADD DM-MS ADDRESSES or U-REQUEST TO REMOVE DM-MS ADDRESSES or U-REQUEST TO REPLACE DM-MS ADDRESS SET
Response expected:	-
Short description:	The infrastructure sends this message to the direct mode gateway MS to indicate that a request is accepted to remove DM-MS addresses. The infrastructure sends this message to the direct mode gateway MS to indicate that a request is accepted to add or replace DM-MS addresses as follows: <ul style="list-style-type: none"> - if the "number of DM-MS addresses" element = 0000₂, this indicates that the list of DM-MS addresses sent by the DM gateway is accepted in full; - if the "number of DM-MS addresses" element ≠ 0000₂, this indicates that the list of DM-MS addresses sent by the DM gateway is accepted except those in the attached list of DM-MS addresses.

NOTE: When the infrastructure sends this message in response to a request to remove DM-MS addresses, it sets the "number of DM-MS addresses" element to 0000₂.

Table B.6: D-ACCEPTANCE OF DM-MS ADDRESSES PDU contents

Information element	Length	Type	C/O/M	Remark
PDU type	4	1	M	
Status downlink	6	1	M	Refer to table B.25
Reserved	8	1	M	Default value = 00000000 ₂
Number of DM-MS addresses	4	1	M	Note 1
DM-MS address	Variable	1	C	Note 2
Proprietary		3	O	
NOTE 1: If "number of DM-MS addresses" ≠ 0000 ₂ , the following DM-MS addresses are not accepted.				
NOTE 2: Shall be repeated as indicated by the "number of DM-MS addresses" information element.				

B.2.1.7 D-COMMAND TO REMOVE DM-MS ADDRESSES

The status downlink information element value "Command to remove DM-MS addresses" indicates the D-COMMAND TO REMOVE DM-MS ADDRESSES PDU and the D-MM STATUS PDU shall contain information elements as defined in table B.7.

Message:	D-COMMAND TO REMOVE DM-MS ADDRESSES
Response to:	-
Response expected:	U-ACCEPTANCE TO REMOVAL OF DM-MS ADDRESSES
Short description:	The infrastructure sends this message to the direct mode gateway MS to inform the DM gateway that the SwMI has removed the attached list of DM-MS addresses from the current DM-MS address set.

Table B.7: D-COMMAND TO REMOVE DM-MS ADDRESSES PDU contents

Information element	Length	Type	C/O/M	Remark
PDU type	4	1	M	
Status downlink	6	1	M	Refer to table B.25
Reserved	8	1	M	Default value = 00000000 ₂
Number of DM-MS addresses	4	1	M	Note 1
DM-MS address	Variable	1	C	Note 2
Proprietary		3	O	
NOTE 1: The "number of DM-MS addresses" information element indicates the number of DM-MS addresses that the SwMI has removed from the current DM-MS address set.				
NOTE 2: Shall be repeated as indicated by the "number of DM-MS addresses" information element.				

B.2.1.8 D-COMMAND TO CHANGE REGISTRATION LABEL

The status downlink information element value "Command to change registration label" indicates the D-COMMAND TO CHANGE REGISTRATION LABEL PDU and the D-MM STATUS PDU shall contain information elements as defined in table B.8.

Message:	D-COMMAND TO CHANGE REGISTRATION LABEL
Response to:	-
Response expected:	U-ACCEPTANCE TO CHANGE REGISTRATION LABEL
Short description:	The infrastructure sends this message to the direct mode gateway MS to instruct the DM gateway to change the registration label.

Table B.8: D-COMMAND TO CHANGE REGISTRATION LABEL PDU contents

Information element	Length	Type	C/O/M	Remark
PDU type	4	1	M	
Status downlink	6	1	M	Refer to table B.25
Reserved	8	1	M	Default value = 00000000 ₂
Proprietary		3	O	

B.2.1.9 D-COMMAND TO STOP DM GATEWAY OPERATION

The status downlink information element value "Command to stop DM gateway operation" indicates the D-COMMAND TO STOP DM GATEWAY OPERATION PDU and the D-MM STATUS PDU shall contain information elements as defined in table B.9.

- Message: D-COMMAND TO STOP DM GATEWAY OPERATION
- Response to: -
- Response expected: U-ACCEPTANCE TO STOP DM GATEWAY OPERATION
- Short description: The infrastructure sends this message to the direct mode gateway MS as a command to stop operating as a DM gateway.

Table B.9: D-COMMAND TO STOP DM GATEWAY OPERATION contents

Information element	Length	Type	C/O/M	Remark
PDU type	4	1	M	
Status downlink	6	1	M	Refer to table B.25
Reserved	8	1	M	Default value = 00000000 ₂
Proprietary		3	O	

B.2.2 U-MM STATUS

B.2.2.1 U-REQUEST TO START DM GATEWAY OPERATION

The status uplink information element value "Request to start DM gateway operation" indicates the U-REQUEST TO START DM GATEWAY OPERATION PDU and the U-MM STATUS PDU shall contain information elements as defined in table B.10.

- Message: U-REQUEST TO START DM GATEWAY OPERATION
- Response to: -
- Response expected: D-ACCEPTANCE TO START DM GATEWAY OPERATION or
D-REJECTION TO START DM GATEWAY OPERATION
- Short description: The direct mode gateway MS sends this message to the infrastructure to request to start operation as a DM gateway. It may include a list of DM-MS addresses, indicating that it wishes to start operation as a DM gateway with that list of DM-MS addresses.
- NOTE: Response D-ACCEPTANCE TO START DM GATEWAY OPERATION indicates that the request is accepted to start operation as a DM gateway. If the gateway included a list of DM-MS addresses in the U-REQUEST TO START DM GATEWAY OPERATION PDU then the D-ACCEPTANCE TO START DM GATEWAY OPERATION PDU may indicate that some of those addresses are not accepted.

Table B.10: U-REQUEST TO START DM GATEWAY OPERATION PDU contents

Information element	Length	Type	C/O/M	Remark
PDU type	4	1	M	
Status uplink	6	1	M	Refer to table B.26
Reserved	8	1	M	Default value = 00000000 ₂
Number of DM-MS addresses	4	1	M	Note 1
DM-MS address	Variable	1	C	Note 2
DMO carrier	13/25	2	O	Note 3
Proprietary		3	O	

NOTE 1: If "number of DM-MS addresses" \neq 0000₂, the gateway includes a list of DM-MS addresses.
NOTE 2: Shall be repeated as indicated by the "number of DM-MS addresses" information element.
NOTE 3: When present this information element shall indicate the direct mode RF carrier.

B.2.2.2 U-REQUEST TO CONTINUE DM GATEWAY OPERATION

The status uplink information element value "Request to continue DM gateway operation" indicates the U-REQUEST TO CONTINUE DM GATEWAY OPERATION PDU and the U-MM STATUS PDU shall contain information elements as defined in table B.11.

Message: U-REQUEST TO CONTINUE DM GATEWAY OPERATION

Response to: -

Response expected: D-ACCEPTANCE TO CONTINUE DM GATEWAY OPERATION or
D-REJECTION TO CONTINUE DM GATEWAY OPERATION

Short description: The direct mode gateway MS sends this message to the infrastructure to request to continue operation as a DM gateway after a re-registration.

NOTE 1: Response D-ACCEPTANCE TO CONTINUE DM GATEWAY OPERATION indicates that the request is accepted to continue operation as a DM gateway. An information element in that response indicates whether the SwMI has retained the previous DM-MS address set for this DM gateway.

NOTE 2: The direct mode gateway MS does not need to request to continue operation as a DM gateway after a periodic registration.

NOTE 3: Use of the U-REQUEST TO CONTINUE DM GATEWAY OPERATION PDU is valid only when the gateway is re-registering in the same network. If the gateway moves to a new network, it needs to use the U-REQUEST TO START DM GATEWAY OPERATION PDU to request to start operation as a DM gateway on the new network.

Table B.11: U-REQUEST TO CONTINUE DM GATEWAY OPERATION PDU contents

Information element	Length	Type	C/O/M	Remark
PDU type	4	1	M	
Status uplink	6	1	M	Refer to table B.26
Reserved	8	1	M	Default value = 00000000 ₂
DMO carrier	13/25	2	O	Note
Proprietary		3	O	

NOTE: When present this information element shall indicate the direct mode RF carrier.

B.2.2.3 U-REQUEST TO STOP DM GATEWAY OPERATION

The status uplink information element value "Request to stop DM gateway operation" indicates the U-REQUEST TO STOP DM GATEWAY OPERATION PDU and the U-MM STATUS PDU shall contain information elements as defined in table B.12.

Message: U-REQUEST TO STOP DM GATEWAY OPERATION

Response to: -

Response expected: D-ACCEPTANCE TO STOP DM GATEWAY OPERATION

Short description: The direct mode gateway MS sends this message to the infrastructure to request to stop operation as a DM gateway.

Table B.12: U-REQUEST TO STOP DM GATEWAY OPERATION PDU contents

Information element	Length	Type	C/O/M	Remark
PDU type	4	1	M	
Status uplink	6	1	M	Refer to table B.26
Reserved	8	1	M	Default value = 00000000 ₂
Proprietary		3	O	

B.2.2.4 U-REQUEST TO ADD DM-MS ADDRESSES

The status uplink information element value "Request to add DM-MS addresses" indicates the U-REQUEST TO ADD DM-MS ADDRESSES PDU and the U-MM STATUS PDU shall contain information elements as defined in table B.13.

Message: U-REQUEST TO ADD DM-MS ADDRESSES

Response to: -

Response expected: D-ACCEPTANCE OF DM-MS ADDRESSES

Short description: The direct mode gateway MS sends this message to the infrastructure to request to add the attached list of DM-MS addresses to the current DM-MS address set.

NOTE: The response (i.e. D-ACCEPTANCE OF DM-MS ADDRESSES PDU) may indicate that some of the DM-MS addresses are not accepted.

Table B.13: U-REQUEST TO ADD DM-MS ADDRESSES PDU contents

Information element	Length	Type	C/O/M	Remark
PDU type	4	1	M	
Status uplink	6	1	M	Refer to table B.26
Reserved	8	1	M	Default value = 00000000 ₂
Number of DM-MS addresses	4	1	M	Note 1
DM-MS address	Variable	1	C	Note 2
Proprietary		3	O	
NOTE 1: The "number of DM-MS addresses" information element indicates the number of DM-MS addresses that the gateway wishes to add to the current DM-MS address set.				
NOTE 2: Shall be repeated as indicated by the "number of DM-MS addresses" information element.				

B.2.2.5 U-REQUEST TO REMOVE DM-MS ADDRESSES

The status uplink information element value "Request to remove DM-MS addresses" indicates the U-REQUEST TO REMOVE DM-MS ADDRESSES PDU and the U-MM STATUS PDU shall contain information elements as defined in table B.14.

Message: U-REQUEST TO REMOVE DM-MS ADDRESSES

Response to: -

Response expected: D-ACCEPTANCE OF DM-MS ADDRESSES

Short description: The direct mode gateway MS sends this message to the infrastructure to request to remove the attached list of DM-MS addresses from the current DM-MS address set.

Table B.14: U-REQUEST TO REMOVE DM-MS ADDRESSES PDU contents

Information element	Length	Type	C/O/M	Remark
PDU type	4	1	M	
Status uplink	6	1	M	Refer to table B.26
Reserved	8	1	M	Default value = 00000000 ₂
Number of DM-MS addresses	4	1	M	Note 1
DM-MS address	Variable	1	C	Note 2
Proprietary		3	O	
NOTE 1: The "number of DM-MS addresses" information element indicates the number of DM-MS addresses that the gateway wishes to remove from the current DM-MS address set.				
NOTE 2: Shall be repeated as indicated by the "number of DM-MS addresses" information element.				

B.2.2.6 U-REQUEST TO REPLACE DM-MS ADDRESS SET

The status uplink information element value "Request to replace DM-MS address set" indicates the U-REQUEST TO REPLACE DM-MS ADDRESS SET PDU and the U-MM STATUS PDU shall contain information elements as defined in table B.15.

Message: U-REQUEST TO REPLACE DM-MS ADDRESS SET

Response to: -

Response expected: D-ACCEPTANCE OF DM-MS ADDRESSES

Short description: The direct mode gateway MS sends this message to the infrastructure to request to replace the current DM-MS address set (if any) with the attached list of DM-MS addresses.

NOTE 1: This message is used if the gateway wishes to replace the current DM-MS address set. It may also be used when the gateway sends the first list of DM-MS addresses i.e. if the gateway has been accepted to start or continue operation as a DM gateway and there is no current DM-MS address set.

NOTE 2: The response (i.e. D-ACCEPTANCE OF DM-MS ADDRESSES PDU) may indicate that some of the DM-MS addresses are not accepted.

Table B.15: U-REQUEST TO REPLACE DM-MS ADDRESS SET PDU contents

Information element	Length	Type	C/O/M	Remark
PDU type	4	1	M	
Status uplink	6	1	M	Refer to table B.26
Reserved	8	1	M	Default value = 00000000 ₂
Number of DM-MS addresses	4	1	M	Note 1
DM-MS address	Variable	1	C	Note 2
Proprietary		3	O	
NOTE 1: The "number of DM-MS addresses" information element indicates the number of DM-MS addresses in the replacement DM-MS address set.				
NOTE 2: Shall be repeated as indicated by the "number of DM-MS addresses" information element.				

B.2.2.7 U-ACCEPTANCE TO REMOVAL OF DM-MS ADDRESSES

The status uplink information element value "Acceptance to removal of DM-MS addresses" indicates the U-ACCEPTANCE TO REMOVAL OF DM-MS ADDRESSES PDU and the U-MM STATUS PDU shall contain information elements as defined in table B.16.

Message: U-ACCEPTANCE TO REMOVAL OF DM-MS ADDRESSES

Response to: D-COMMAND TO REMOVE DM-MS ADDRESSES

Response expected: -

Short description: The direct mode gateway MS sends this message to the infrastructure to indicate that it accepts that the SwMI has removed DM-MS addresses from the current DM-MS address set.

Table B.16: U-ACCEPTANCE TO REMOVAL OF DM-MS ADDRESSES PDU contents

Information element	Length	Type	C/O/M	Remark
PDU type	4	1	M	
Status uplink	6	1	M	Refer to table B.26
Reserved	8	1	M	Default value = 00000000 ₂
Proprietary		3	O	

B.2.2.8 U-ACCEPTANCE TO CHANGE REGISTRATION LABEL

The status uplink information element value "Acceptance to change registration label" indicates the U-ACCEPTANCE TO CHANGE REGISTRATION LABEL PDU and the U-MM STATUS PDU shall contain information elements as defined in table B.17.

Message: U-ACCEPTANCE TO CHANGE REGISTRATION LABEL

Response to: D-COMMAND TO CHANGE REGISTRATION LABEL

Response expected: -

Short description: The direct mode gateway MS sends this message to the infrastructure to indicate that it accepts the command to change the registration label.

Table B.17: U-ACCEPTANCE TO CHANGE REGISTRATION LABEL PDU contents

Information element	Length	Type	C/O/M	Remark
PDU type	4	1	M	
Status uplink	6	1	M	Refer to table B.26
Reserved	8	1	M	Default value = 00000000 ₂
Proprietary		3	O	

B.2.2.9 U-ACCEPTANCE TO STOP DM GATEWAY OPERATION

The status uplink information element value "Acceptance to stop DM gateway operation" indicates the U-ACCEPTANCE TO STOP DM GATEWAY OPERATION PDU and the U-MM STATUS PDU shall contain information elements as defined in table B.18.

Message: U-ACCEPTANCE TO STOP DM GATEWAY OPERATION

Response to: D-COMMAND TO STOP DM GATEWAY OPERATION

Response expected: -

Short description: The direct mode gateway MS sends this message to the infrastructure to indicate that it accepts the command to stop operating as a DM gateway.

Table B.18: U-ACCEPTANCE TO STOP DM GATEWAY OPERATION PDU contents

Information element	Length	Type	C/O/M	Remark
PDU type	4	1	M	
Status uplink	6	1	M	Refer to table B.26
Reserved	8	1	M	Default value = 00000000 ₂
Proprietary		3	O	

B.3 Information element definitions

The information elements used in the D-MM STATUS and U-MM STATUS PDU sub-PDUs relating to DM gateway operation are defined in the following clauses.

NOTE: The DM-MS address information element (as defined in clause B.3.1) may also be used as a type 3 element in appropriate call control, SDS and MM security PDUs (see clause B.1).

B.3.1 DM-MS address

The DM-MS address information element shall indicate a DM-MS address. It is used in the D-MM STATUS and U-MM STATUS PDU sub-PDUs relating to DM gateway operation when the infrastructure or DM gateway sends a list of DM-MS addresses (see clause B.2).

The DM-MS address information element may also be used as a type 3 element in appropriate call control and SDS PDUs (see clause B.1); i.e. the element may be used by a DM gateway if it wishes to inform the infrastructure of the address of the source DM-MS, and may be used by the infrastructure when it sends a PDU to a DM gateway if it wishes to indicate the address of the destination DM-MS.

The DM-MS address information element may contain either the DM-MS SSI or TSI, as shown in table B.19. The DM-MS address extension is needed only if it is different from the MNI of the SwMI.

Table B.19: DM-MS address information element contents

Information sub-element	Length	Type	C/O/M	Remark
DM-MS identity address type	1	1	M	
DM-MS SSI	24	1	M	
DM-MS address extension	24	1	C	Note
NOTE: Shall be present only when the DM-MS identity address type indicates "DM-MS TSI".				

B.3.2 DM-MS identity address type

The DM-MS identity address type information element shall indicate the type of DM-MS address, as defined in table B.20.

Table B.20: DM-MS identity address type information element contents

Information element	Length	Value	Remark
DM-MS identity address type	1	0	DM-MS SSI
		1	DM-MS TSI

B.3.3 DM-MS SSI

The DM-MS SSI information element shall indicate the Short Subscriber Identity (SSI) address of the DM-MS, as defined in table B.21.

Table B.21: DM-MS SSI information element contents

Information element	Length	Value	Remark
DM-MS SSI	24		See EN 300 396-1 [1], clause 6

B.3.4 DM-MS address extension

The DM-MS address extension information element shall indicate the extended part of the TETRA Subscriber Identity (TSI) address of the DM-MS, as defined in table B.22. It is needed only if the MNI of the DM-MS is different from the MNI of the SwMI.

Table B.22: DM-MS address extension information element contents

Information sub-element	Length	Value	Remark
DM-MS Mobile Country Code (MCC)	10		See EN 300 396-1 [1], clause 6
DM-MS Mobile Network Code (MNC)	14		See EN 300 396-1 [1], clause 6

B.3.5 DMO carrier

See EN 300 392-2 [5], clause 16 for the definition of the DMO carrier information element.

B.3.6 Number of DM-MS addresses

The number of DM-MS addresses information element shall indicate the number of "DM-MS address" information elements that follow in the PDU, as defined in table B.23.

NOTE: Each "DM-MS address" information element comprises a set of information sub-elements i.e. DM-MS identity address type and DM-MS SSI, and also DM-MS address extension if DM-MS identity address type = 1. The information sub-elements in each DM-MS address in the PDU need to be in the order specified in clause B.3.1.

Table B.23: Number of DM-MS addresses information element contents

Information element	Length	Value	Remarks
Number of DM-MS addresses	4	0000 ₂	No DM-MS addresses
		0001 ₂	One DM-MS address
		0010 ₂	2 DM-MS addresses
		etc.	etc.
		1111 ₂	15 DM-MS addresses

B.3.7 PDU type

See EN 300 392-2 [5], clause 16 for the definition of the PDU type information element.

B.3.8 Proprietary

See EN 300 392-2 [5], clause 16 for the definition of the proprietary information element.

B.3.9 Retained DM-MS address set

The retained DM-MS address set information element shall indicate whether the SwMI has retained the previous DM-MS address set for a DM gateway that is continuing operation, as defined in table B.24.

Table B.24: Retained DM-MS address set information element contents

Information element	Length	Value	Remark
Retained DM-MS address set	1	0	SwMI does not have a DM-MS address set for this DM gateway
		1	SwMI has retained the previous DM-MS address set for this DM gateway

B.3.10 Status downlink

The status downlink information element shall indicate the requested service or a response to a request, and the sub-type of the D-MM STATUS PDU, as defined in table B.25.

Table B.25: Status downlink information element contents

Information element	Length	Value	Remark
Status downlink	6	000000 ₂ to 001111 ₂	As defined in EN 300 392-2 [5], clause 16
		010000 ₂	Acceptance to start DM gateway operation
		010001 ₂	Rejection to start DM gateway operation
		010010 ₂	Acceptance to continue DM gateway operation
		010011 ₂	Rejection to continue DM gateway operation
		010100 ₂	Acceptance to stop DM gateway operation
		010101 ₂	Acceptance of DM-MS addresses
		010110 ₂	Command to remove DM-MS addresses
		010111 ₂	Command to change registration label
		011000 ₂	Command to stop DM gateway operation
		011001 ₂	Reserved
		etc.	etc.
		011111 ₂	Reserved
		100000 ₂ to 111111 ₂	As defined in EN 300 392-2 [5], clause 16

B.3.11 Status uplink

The status uplink information element shall indicate the requested service or a response to a request, and the sub-type of the U-MM STATUS PDU, as defined in table B.26.

Table B.26: Status uplink information element contents

Information element	Length	Value	Remark
Status uplink	6	000000 ₂ to 001111 ₂	As defined in EN 300 392-2 [5], clause 16
		010000 ₂	Request to start DM gateway operation
		010001 ₂	Request to continue DM gateway operation
		010010 ₂	Request to stop DM gateway operation
		010011 ₂	Request to add DM-MS addresses
		010100 ₂	Request to remove DM-MS addresses
		010101 ₂	Request to replace DM-MS address set
		010110 ₂	Acceptance to removal of DM-MS addresses
		010111 ₂	Acceptance to change registration label
		011000 ₂	Acceptance to stop DM gateway operation
		011001 ₂	Reserved
		etc.	etc.
		011111 ₂	Reserved
		100000 ₂ to 111111 ₂	As defined in EN 300 392-2 [5], clause 16

Annex C (informative): Change requests

The present document contains change requests as described in the following table.

No	CR vers.	Standard Version	TS	EN	Clauses affected	Title
001	04	1.2.1		X	6.2.1.1, 6.2.2.1, 7.3.2.2.2, 8.4.2.2.1.1, 14.1.2	Gateway inter-working improvements
002	01	1.2.1		X	4.1, 4.2, 6.2, 6.2.4.2, 6.2.5.3, 6.2.6, 6.3, 6.3.1.2, 6.3.1.4.1, 8.4, 8.4.2.4.2, 8.4.4.3, 8.5.2.2, 8.5.4.2, 8.5.6.2, 8.6.1, 8.6.3.2.1	Gateway inter-working improvements – monitoring master link
003	02	1.2.1			4.1, 4.2, 6.2.6, 6.3.1.2, 6.6.1, 8.4, 8.4.4, 8.4.4.6, 8.4.7.4, 8.5.2.1.4, 8.5.6.2, 8.5.7.1, 8.5.7.3, 13.4.8.1.1	Gateway inter-working improvements – pre-emption on master link
004	03	1.2.1		X	14.3.9	Power class definition
005	04	1.2.1		X	3.2, 6.6.1, 14.1.2, 14.3.1, 14.3.2, 14.3.4A, 14.3.4B, 14.3.23	Encrypted URT address

History

Document history		
Edition 1	January 2000	Publication as ETS 300 396-5
V1.2.1	May 2006	Publication
V1.3.0	August 2011	One-step Approval Procedure OAP 20111222: 2011-08-24 to 2011-12-22
V1.3.1	December 2011	Publication